



1-5	Module Locations	13	Mid MC Relay Card
6	Front M1 Overview	14	Mid M1 Low Current Card
7	Front M1 Slide Card	15	Mid M1 RSI-12
8	Front M1 HC relay Card	16	Mid M1 Overview (6 Card)
9	Front M1 Breaker (Card 3)	17	Mid M1 (Cont.) (6 Card)
10	Front M1 Breaker (Card 4)	18	Mid M1 HC 5 (6 Card)
11	Dash M1 Module	19	Rear M1 Overview
12	Mid M1 Overview (4 Card)	20	Rear M1 Cards 1 & 2









Schematic Connections Legend

- Constant Ground
- Constant 12V+
- Switched Ground
- Switched 12V+
- Reverse Polarity
- Signal
- 120V AC Line
- Network

21	Rear M1 Cards 3 & 4
22	Interior Lighting
23	Exterior Lighting
24	Slides
25	HVAC
26	Floor Heat
27	Vent Fans
28	Tanks

29	Bed Lift
30	MoRyde TV Lift
31	Whisper Ride TV Lift
32	TV Lift Location
33	Dash Shade Module
34	HCR-11 Drop Tap
35	Front Shade Module
36	Merge System

Schematic Connections Legend

-  Constant Ground
-  Constant 12V+
-  Switched Ground
-  Switched 12V+
-  Reverse Polarity
-  Signal
-  120V AC Line
-  Network

37	Merge Logic
38	EMS
39	Inverter Assist
40	Wireless Switches
41	Generator
42	Mechanical
43	Blue Network (Port 1)
44	Blue Network Continued

45	Yellow Network (Port 2)
46	Yellow Network (Cont)
47	Orange Network (Port 3)
48	Orange Network (Port 4)
49	Ports 5 & 6
50	Always On
51	DCD Panel
52	Dash SSP25 Panels

Schematic Connections Legend

	Constant Ground
	Constant 12V+
	Switched Ground
	Switched 12V+
	Reverse Polarity
	Signal
	120V AC Line
	Network



53

Power Diagram

54

Power Diagram Continued

55

Connectors

Schematic Connections Legend

 Constant Ground

 Constant 12V+

 Switched Ground

 Switched 12V+

 Reverse Polarity

 Signal

 120V AC Line

 Network

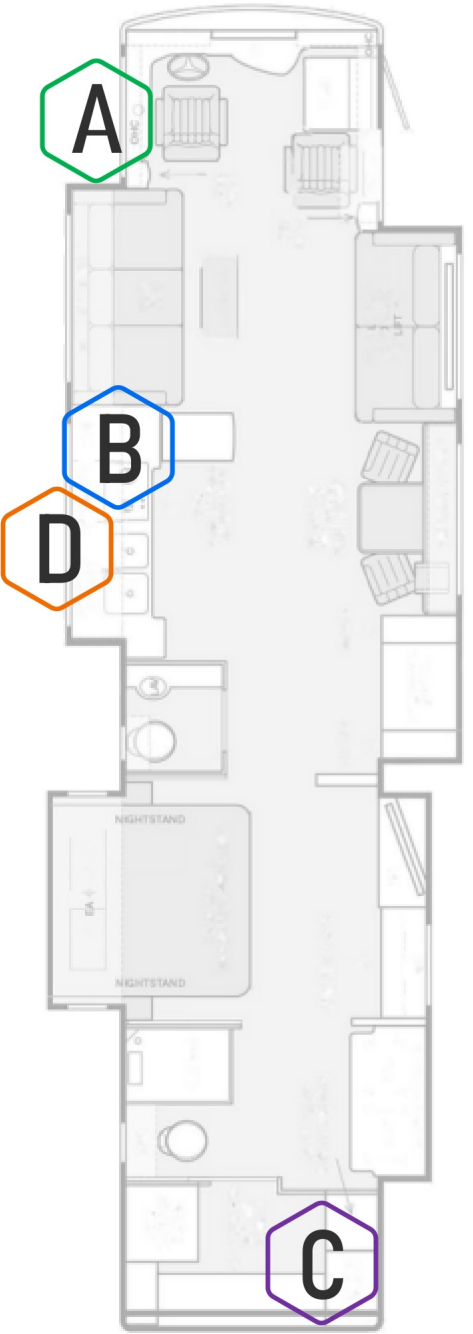

A Front M1 Panel

i Spyder Part # BENCZM2DS
Tiffin Part # 5126983
Dimensions 10" X 7.8"

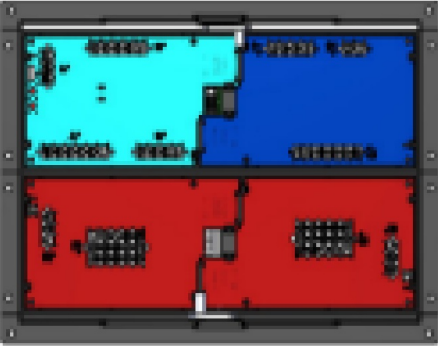

D/S Ext Compartment

B Mid M1 Panel

i Spyder Part # BENCZM4C2 (4 Card)
OR BENCZM4C3 (6 Card)
Tiffin Part # 5145849 (4 Card)
OR 5145815 (6 Card)

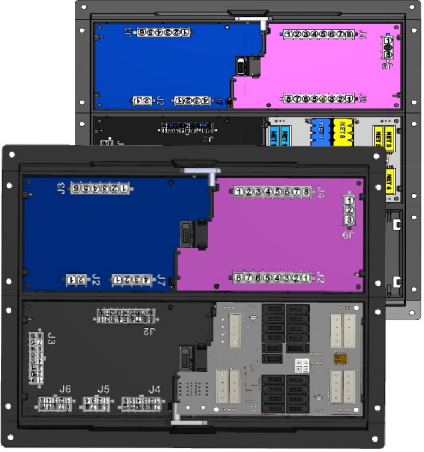

Inverter Bay

C Rear M1 Panel

i Spyder Part # BENCZM6DP
Tiffin Part # 5127300
Dimensions 9.1" X 10"

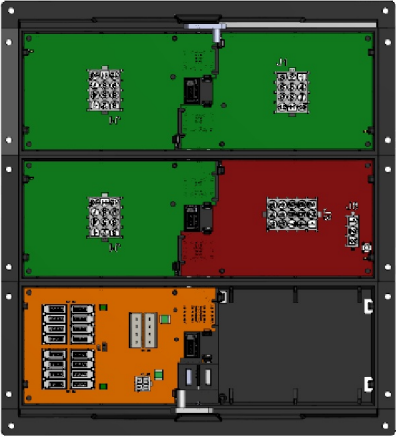

Rear Closet

D DCD Panel

i Spyder Part # BENCZ38DP
Tiffin Part # 5127298
Dimensions 13.5" X 12.5"

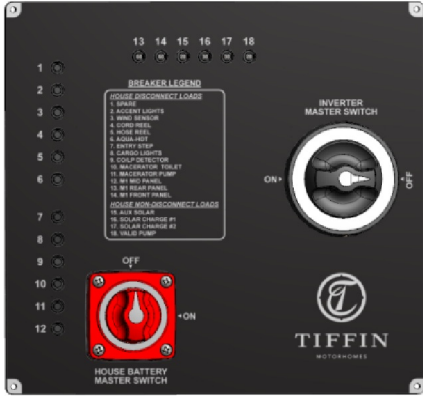

Inverter Bay



E 10" Pro LCD

i Spyder Part # BSSPZZXF

Dimensions 10.5" X 7.3"



📍 Hall Wall

F Mira Module

i Spyder Part # BMODZ56VF

Tiffin Part # 5114034

Dimensions 4" X 2.5"



📍 Front Overhead Cabinet

G HCR15 TV Lift

i Spyder Part # BMODZQFCN-A

Tiffin Part # 5134953

Dimensions 3" X 3"

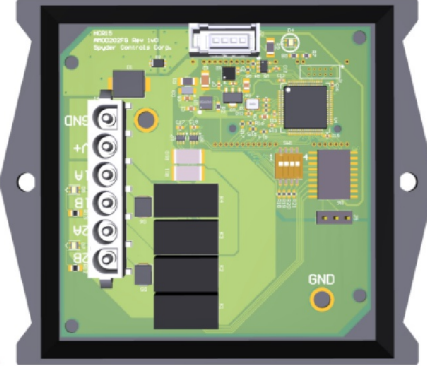

📍 Rear Closet

H Bridge Module

i Spyder Part # BMODZTCT0

Tiffin Part # 5127271

Dimensions 2.7" X 2.7"

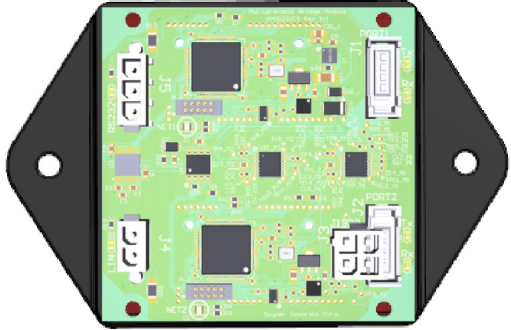

📍 Rear Closet

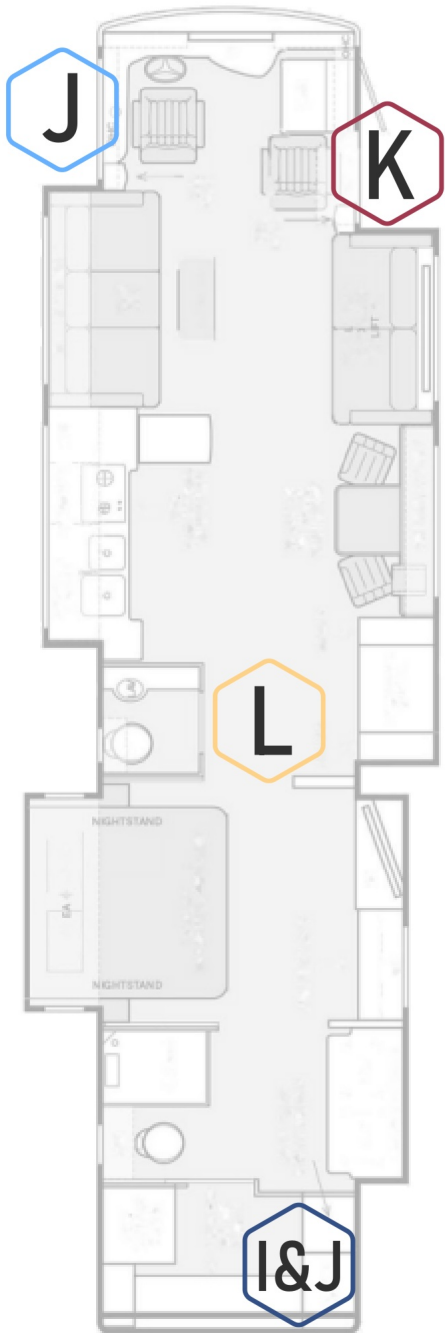

I ACR3



Spyder Part #
BMODZYACG-B

Tiffin Part #
5091114

Dimensions
6" X 4.8"

Rear Closet

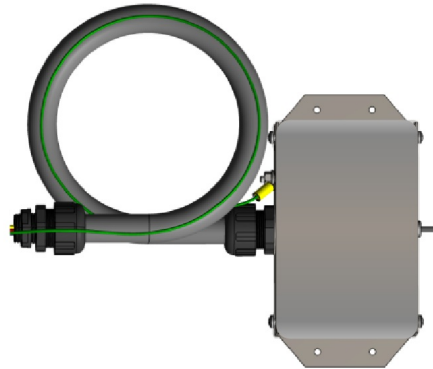

J HCR-12



Spyder Part #
BMODZJ2T0

Tiffin Part #
5076028

Dimensions
8" X 3"

Rear Closet

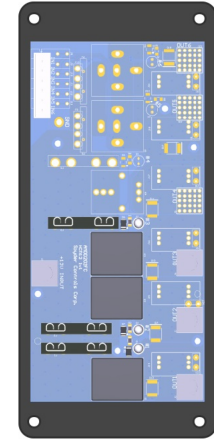

K Dash Shade Module



Spyder Part #
BMODZMKM1-T

Tiffin Part #
5127302

Dimensions
5.4" X 3.5"

P/S Front Overhead Cabinet

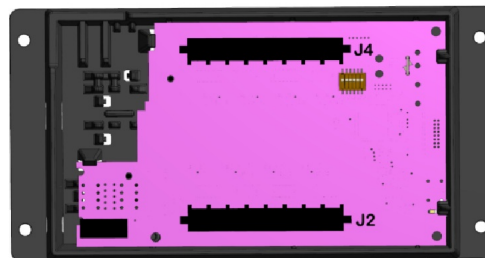

L RF Hub



Spyder Part #
BMODZRFT0-W

Tiffin Part #
5141264

Dimensions
5.1" DIA

Ceiling



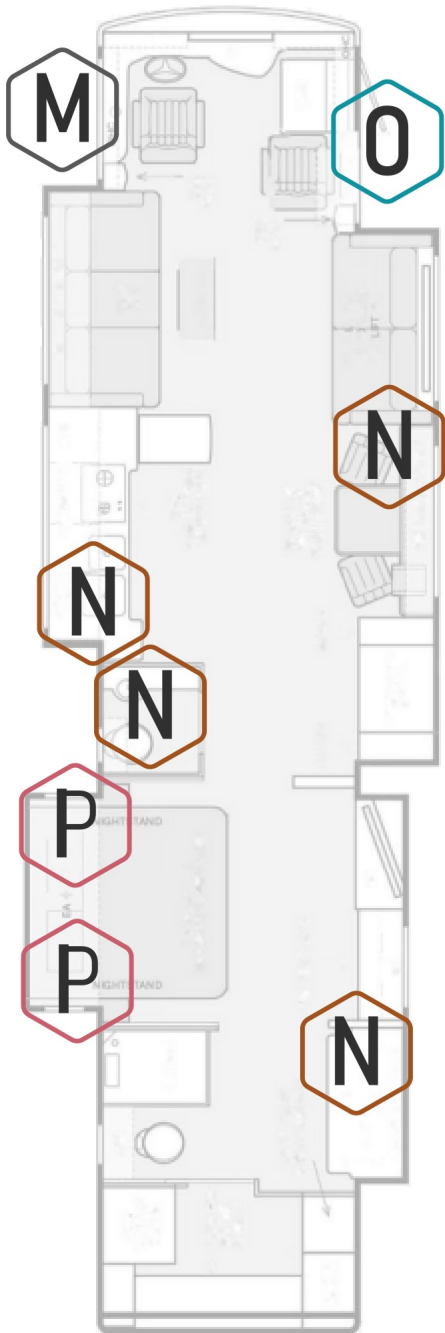

Terminator HCR-11



Spyder Part #
BMODZGAN6-1
Tiffin Part #
5131310

Dimensions
2.5" X 2"

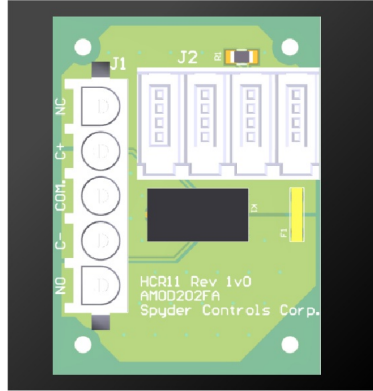

Front D/S Compartment



3.5" LCD



Spyder Part #
BSSPZZTED
Tiffin Part #
5127291

Dimensions
4.5" X 2.9"



Interior



5" Exterior LCD



Spyder Part #
BSSPZZZEN
Tiffin Part #
5145817

Dimensions
5.9" X 4"



Outside Entry Door



5" LCD



Spyder Part #
BSSPZZREK
Tiffin Part #
5127269

Dimensions
5.7" X 3.6"

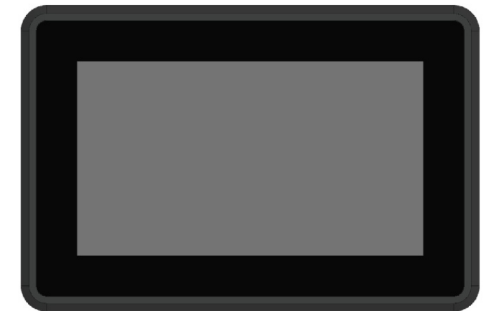

Interior



**2x3 Button
SSP25**



Spyder Part #
(1)BASPZ523HDTO-1A,
(2)BASPZ523HDTO-1B
Tiffin Part #
(1) 5169653,
(2) 5169652
Dimensions
3.6" X 2.8"

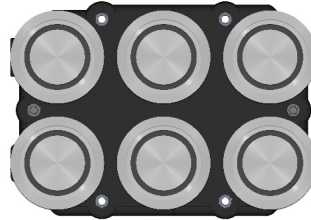

Front Dash Driver's Side



**2x6 Button
SSP25**



Spyder Part #
BASPZ526HDTO-1A

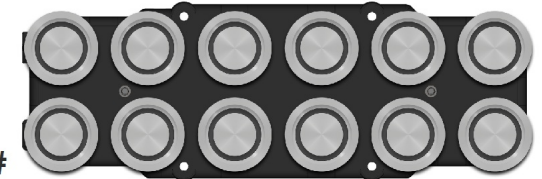

Tiffin Part #
5169651

Dimensions
7.3" X 2.8"

Front Dash



**M1 Dash
Module**



Spyder Part #
BENCZM7C1
Tiffin Part #
5170290
Dimensions
10.8" X 3.5"

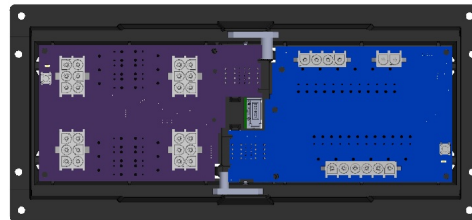

Behind Dash

M1 Slide Card

- Awning Constant
- Undercoach Constant
- Slide Breaker #1
- Slide Breaker #2
- Slide Breaker #3
- Ignition (12V)
- Park Brake (GND)
- P/S FR Slide EXT
- P/S FR Slide RET
- D/S FR Slide EXT
- D/S FR Slide RET
- P/S RR Slide EXT
- P/S RR Slide RET
- D/S RR Slide EXT
- D/S RR Slide RET
- Hydraulic Pump

M1 HC Relay

- Windshield Accent
- Water Pump
- Headlights
- Door/Assist Handle
- Slide Box
- U-Coach
- Awning Lt
- Road Lt
- Porch Lt
- Map
- Spare LS
- Spare LS

Dip Switch Settings

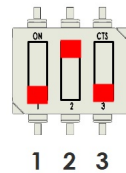

- 1 OFF (Down)
- 2 ON (Up)
- 3 OFF (Down)

Front M1 Panel

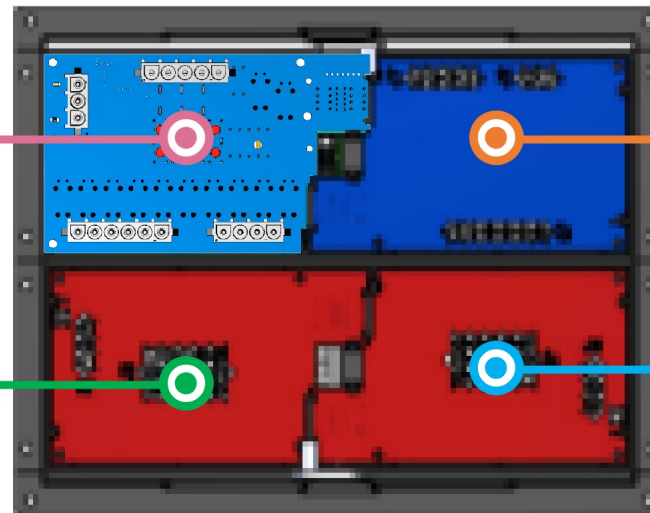

M1 Breaker (Card 3)

- Camera/Radio (IGN)
- Jack Buzzer (IGN)
- CB/Satellite
- Panel Lamp/Head LT (IGN)
- 12V Outlet 1/USB PWR
- HCR11 PWR
- Euro Loft (IGN)
- TV Relay/Fridge/Dash SHD MOD (IGN)
- HVAC Denso (IGN)
- Dock Light
- Entry Step SW
- Dash USB/PS USB PWR
- IGN (12V)

M1 Breaker (Card 4)

- 12V Outlet 2/ USB PWR
- Engine Preheat SW
- Electric Step Cover
- Power Window (IGN)
- D/S Mirror PWR (IGN)
- P/S Mirror PWR (IGN)
- Seat Power #1
- Seat Power #2
- Dash Shade Module
- Fans/Radio
- Radio Mem/XM PWR
- HVAC Denso
- IGN (+12V)

Front M1 Panel

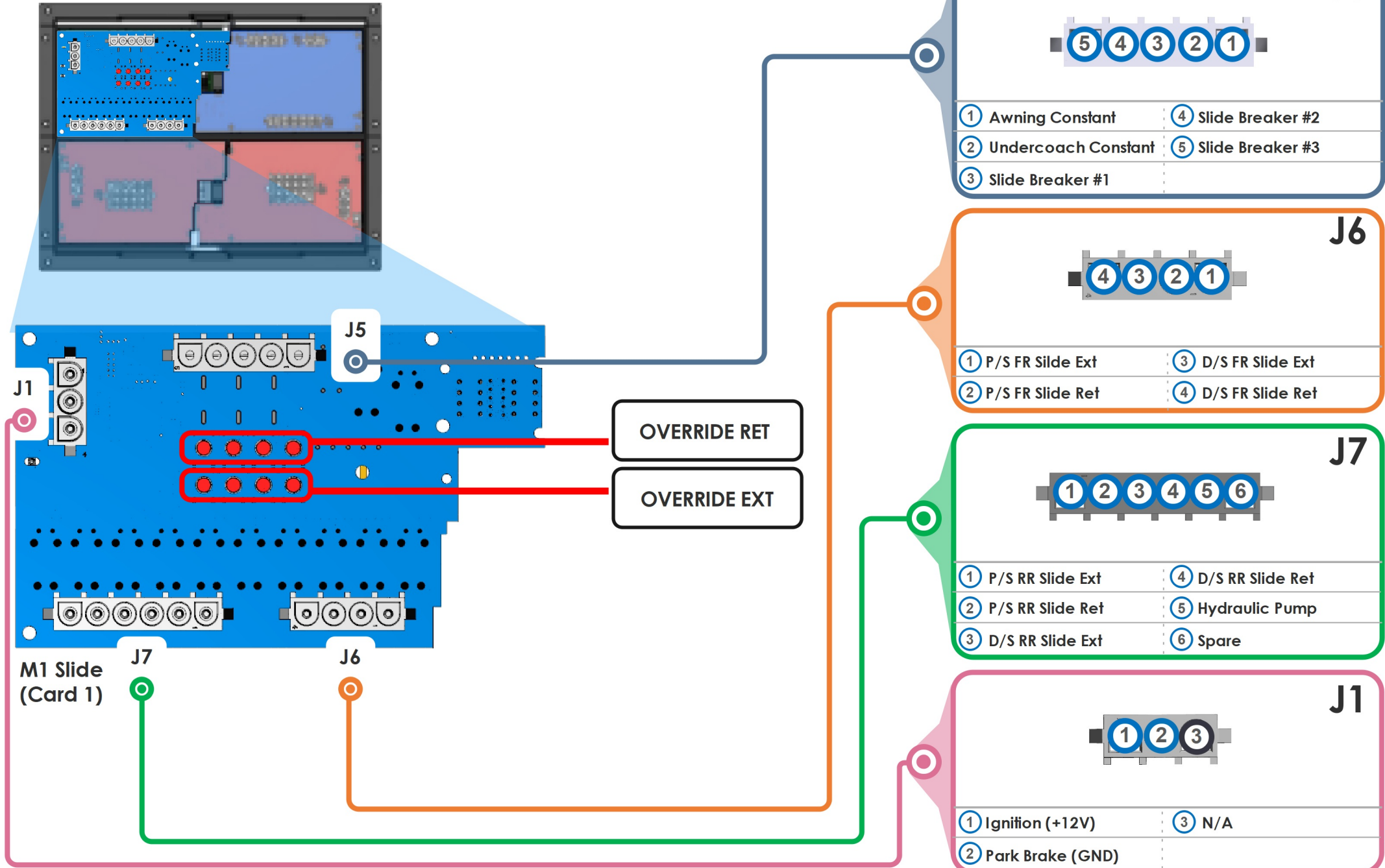
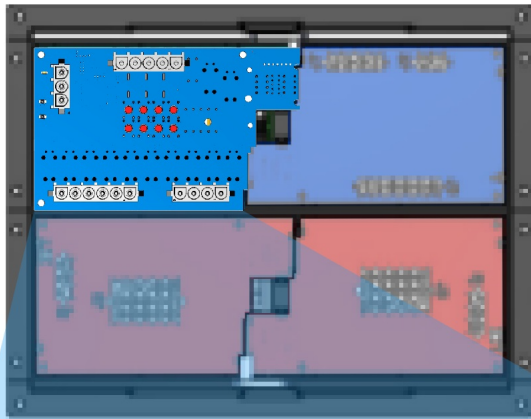

Front M1 Panel

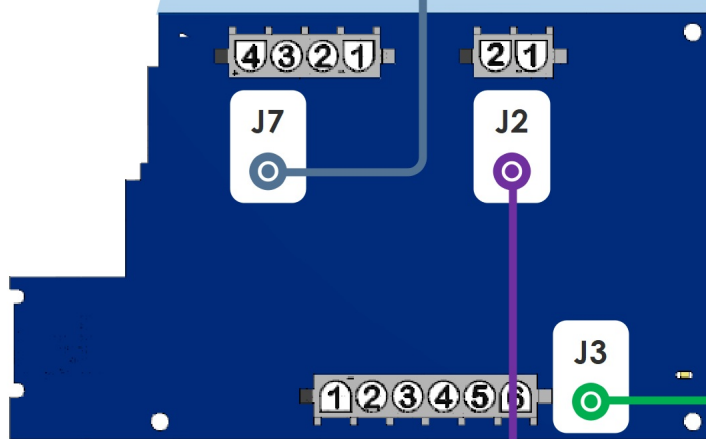
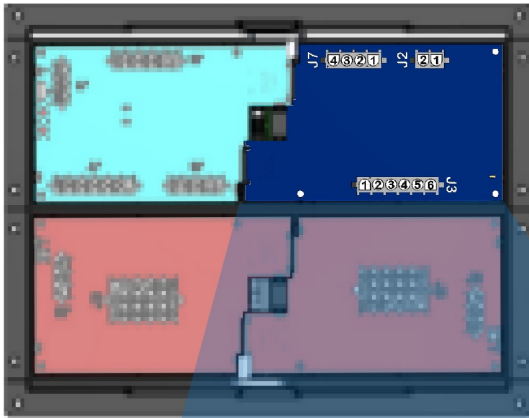

M1 HC Relay (Card 2)

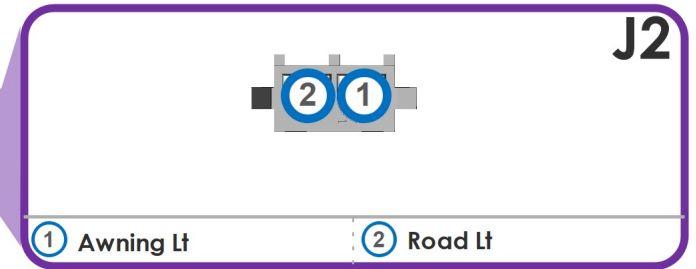
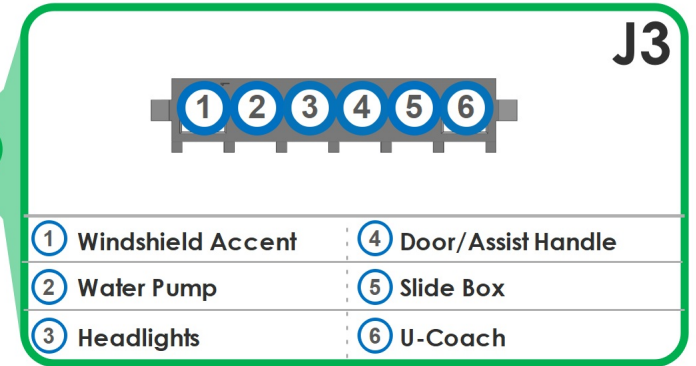
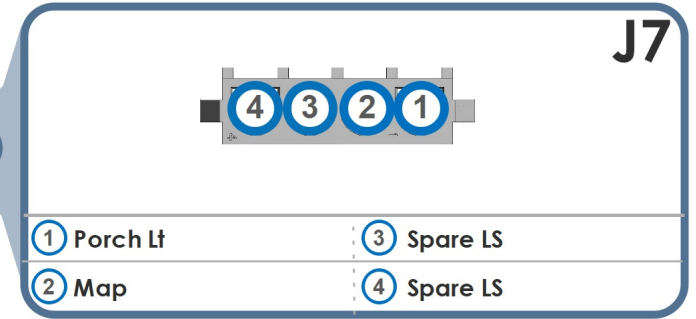

Front M1 Panel

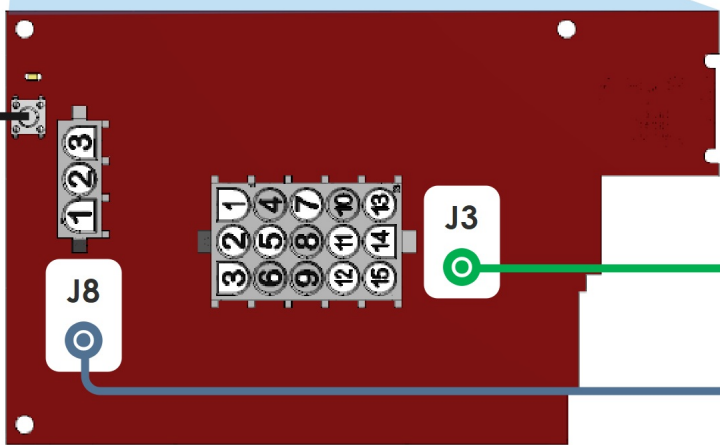
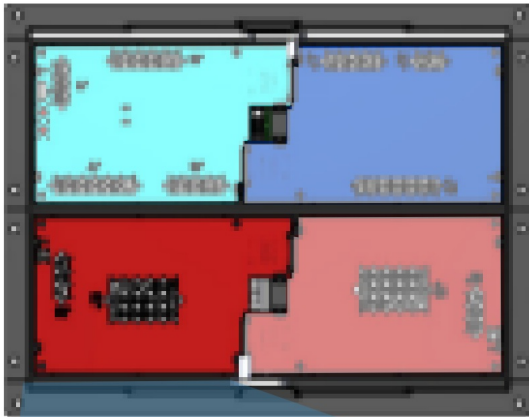

M1 Breaker (Card 3)

Breaker Reset

J3

1	4	7	10	13
2	5	8	11	14
3	6	9	12	15

① Dash USB/ PS USB PWR	⑨ Panel Lamp/Head LT IGN
② Camera/Radio (IGN)	⑩ HVAC Denso (IGN)
③ Jack Buzzer (IGN)	⑪ N/A
④ Entry Step SW	⑫ 12V Outlet 1/USB PWR
⑤ N/A	⑬ TV Relay/Fridge/Dash SHD MOD (IGN)
⑥ CB/Satellite	⑭ Euro Loff (IGN)
⑦ Dock Light	⑮ HCR11 PWR
⑧ N/A	

J8

1	2	3
---	---	---

① IGN (+12V)	② N/A
--------------	-------

Front M1 Panel

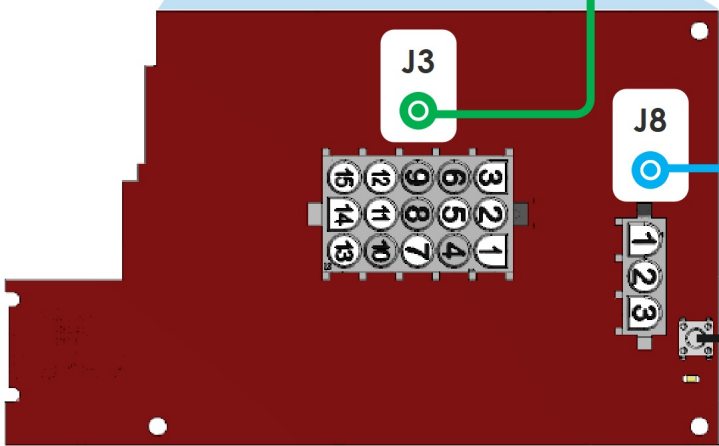
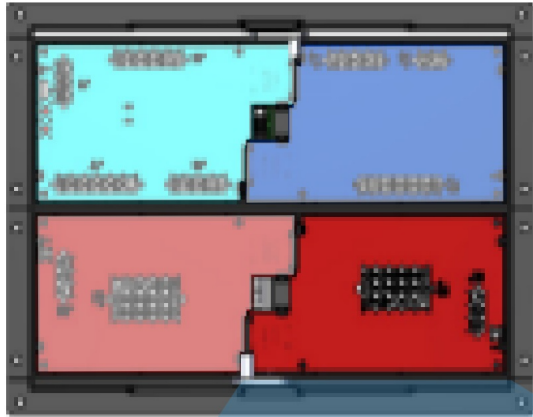

M1 Breaker (Card 4)

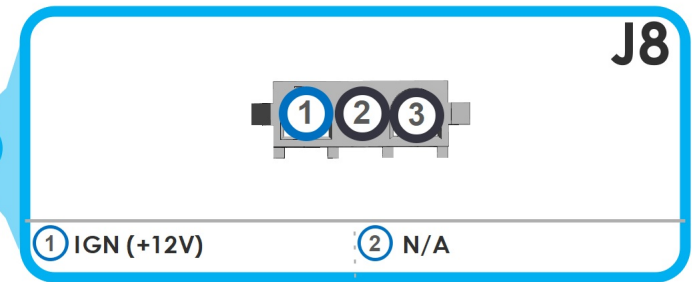
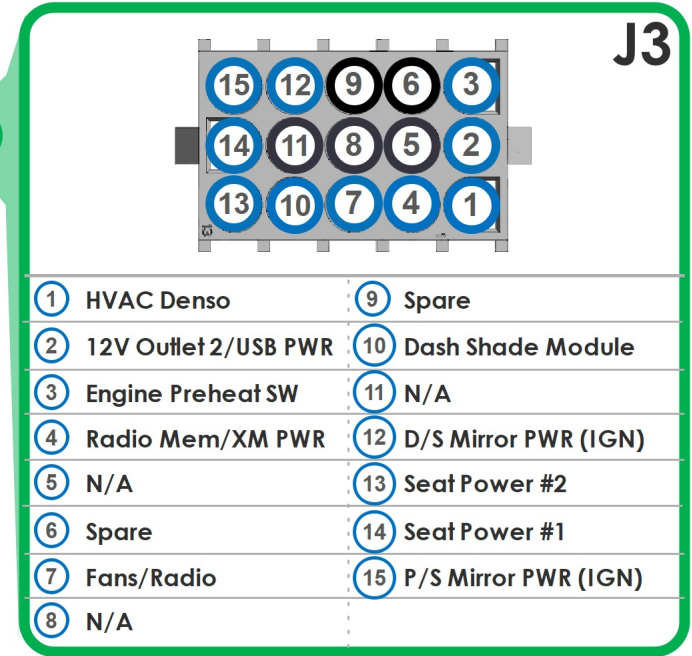

Breaker Reset

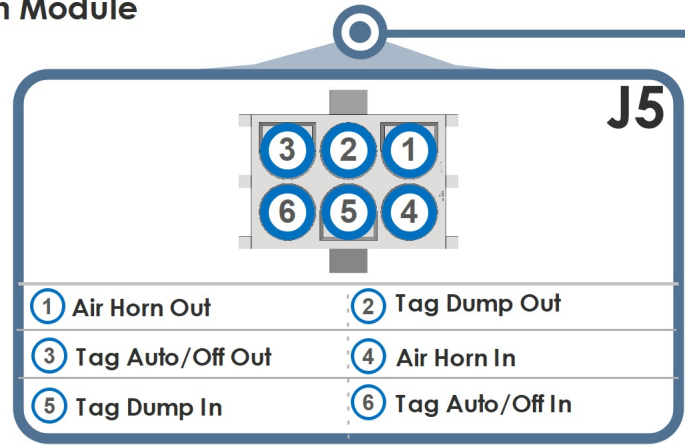
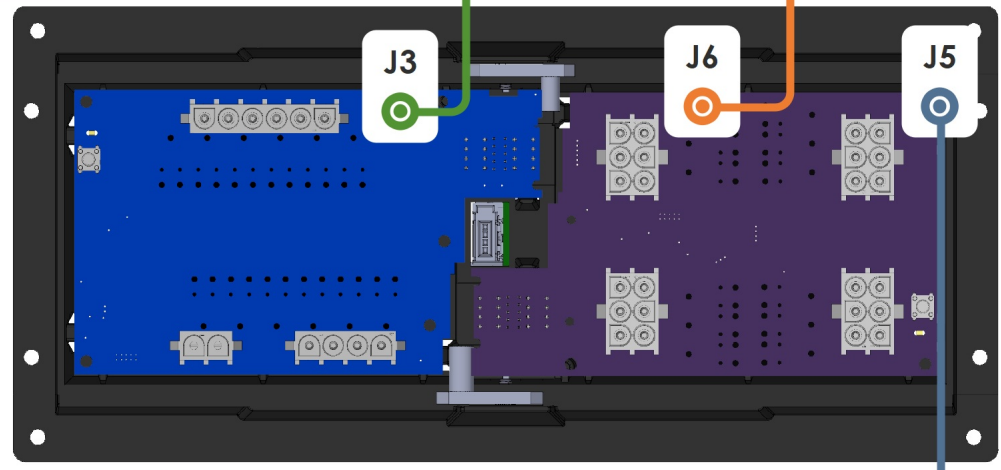
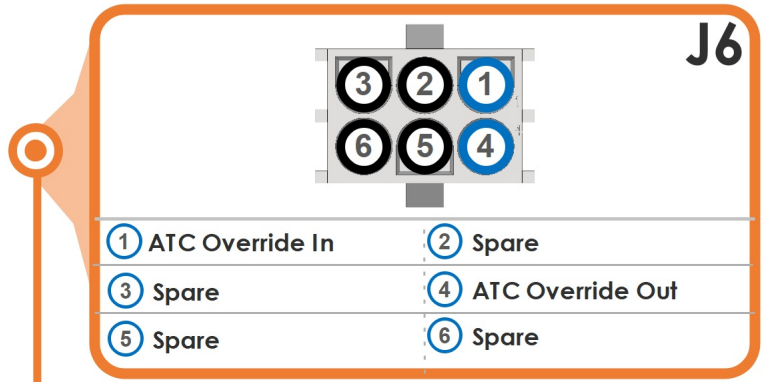
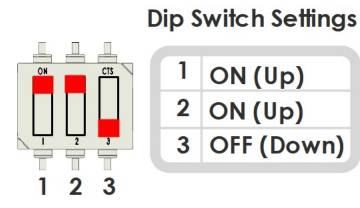
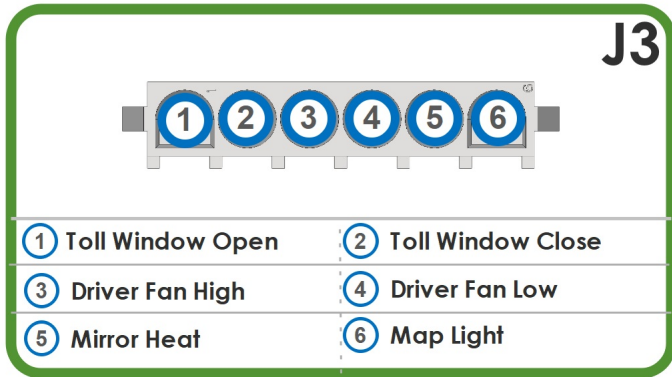

M1 HC Relay

- Bed Lift UP
- Bed Lift DOWN
- PS Fan HI
- PS Fan LO
- Bay Door Lock
- Bay Door Unlock
- Step Cover EXT
- Step Cover RET
- Door Awning EXT
- Door Awning RET
- Entry Door Lock
- Entry Door Unlock

M1 Low Current

- RR Bath NT SHD UP
- RR Bath NT SHD UP
- Horn (GND)
- Furnace FR
- Furnace RR
- Gen Start (GND)
- Gen Stop (GND)
- Galley SHD UP
- Galley SHD DN
- Galley NT SHD UP
- Galley NT SHD DN
- Sofa Day SHD UP
- Sofa Day SHD DN
- Sofa NT SHD UP
- Sofa NT SHD DN

Dip Switch Settings

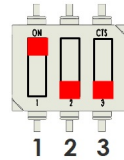

- | | |
|---|------------|
| 1 | ON (Up) |
| 2 | OFF (Down) |
| 3 | OFF (Down) |

Mid M1 Panel

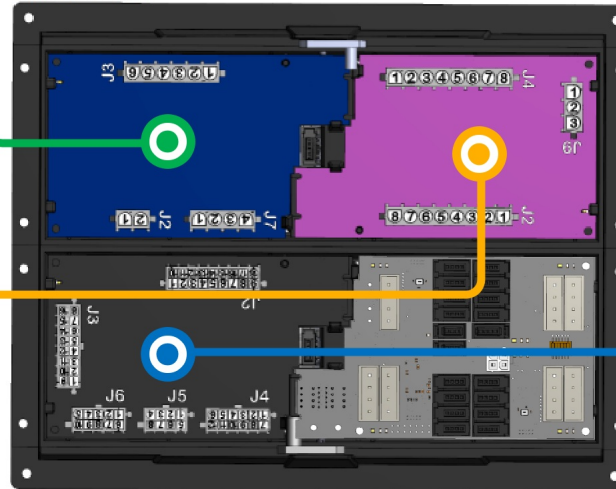

RSI-12

- IGN (+12V)
- GEN Fault (+12V)
- HSE Disconnect Sense (+12V)
- Bed Lift Plunger (+12V)
- Park Brake (GND)
- Water Pump (GND)
- Entry Door Pin SW (GND)
- Merge Input (GND)
- Dash Accent ON (GND)
- Dash Accent OFF (GND)
- LP Gas
- LP GND
- Spare
- GEN Run Signal (+12v)
- RTC 12V Constant PWR
- FR Floor Heat Thermistor
- RR Floor Heat Thermistor
- Front A/C Thermistor
- Mid A/C Thermistor
- Rear A/C Thermistor
- Bay Thermistor
- Ext Temp

i 4 Card M1 Option

This page and the following three pages only apply if the coach is NOT equipped with window awnings

Mid M1 Panel

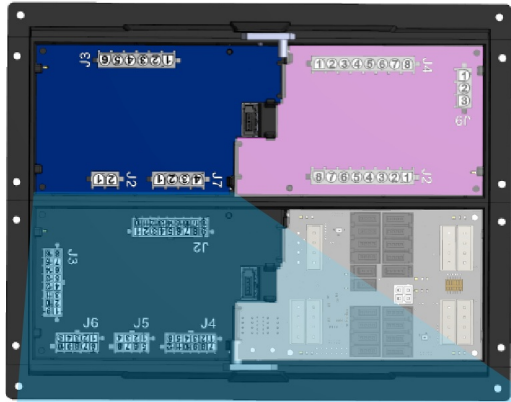

Mid M1 HC Relay (Card 1)

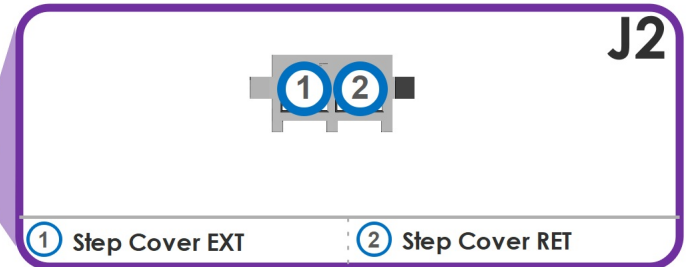
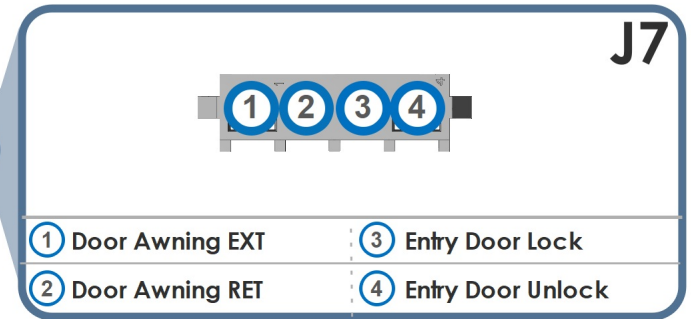
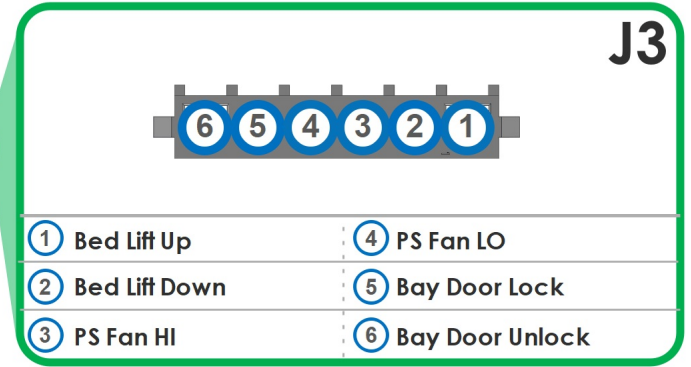
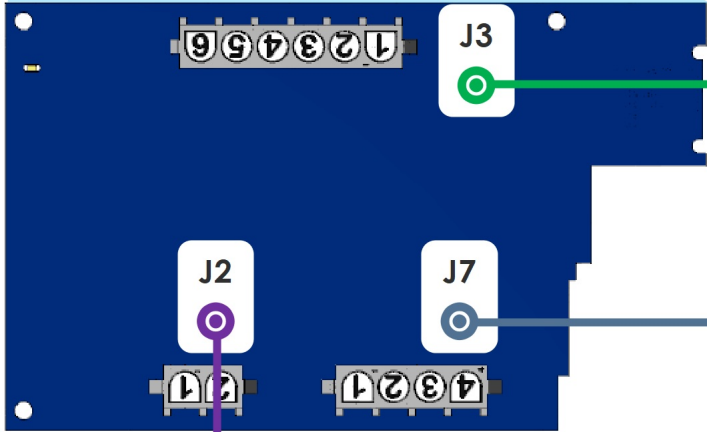

Mid M1 Panel

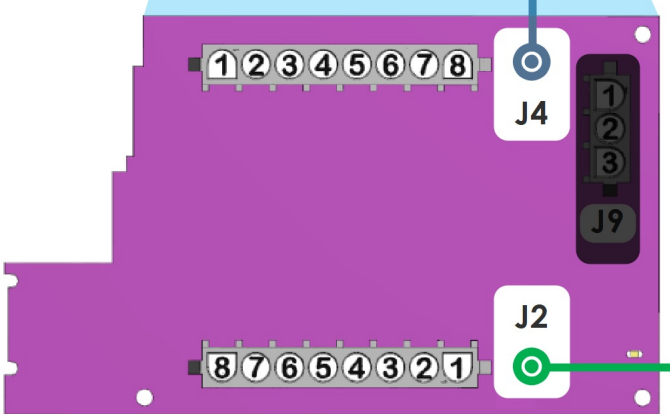
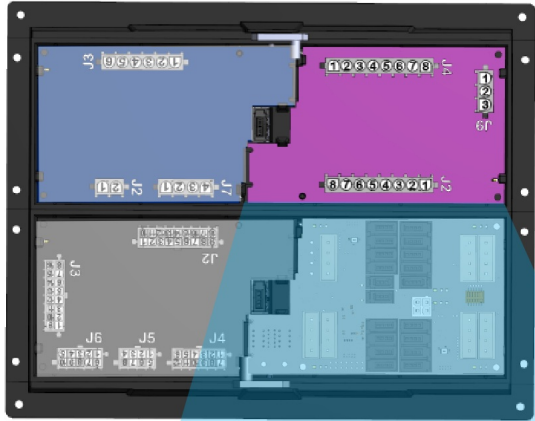

M1 LC Half Bridge

J4

① RR Bath NT SHD UP	⑤ Furnace FR
② RR Bath NT SHD DN	⑥ Furnace RR
③ Spare	⑦ GEN Start (GND)
④ Horn (GND)	⑧ GEN Stop (GND)

J2

① Galley SHD UP	⑤ Sofa Day SHD UP
② Galley SHD DN	⑥ Sofa Day SHD DN
③ Galley NT SHD UP	⑦ Sofa NT SHD UP
④ Galley NT SHD DN	⑧ Sofa NT SHD DN

Mid M1 Panel

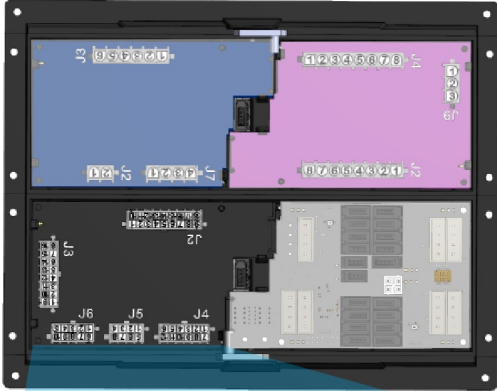

RSI-12

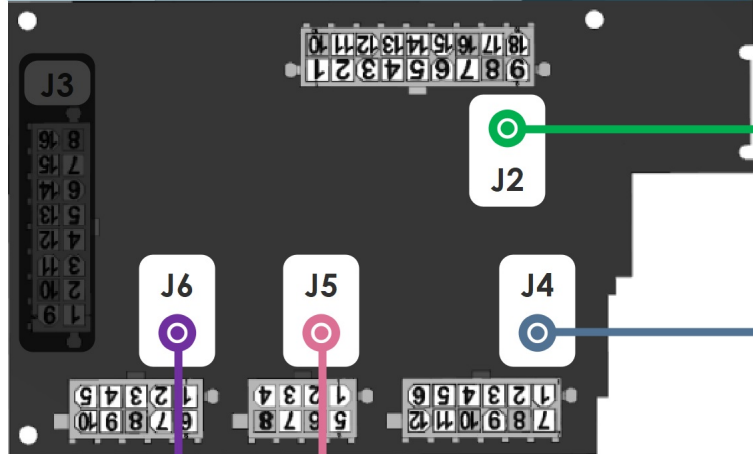

J2

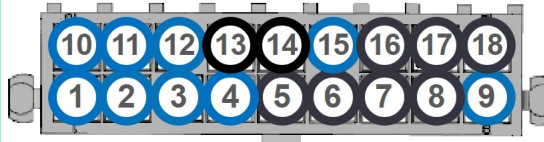

① IGN (+12V)	⑩ Water Pump (GND)
② GEN Fault (+12V)	⑪ Entry Door Pin SW (GND)
③ HSE Disconnect Sense (+12V)	⑫ Merge Input (GND)
④ Bed Lift Plunger (+12V)	⑬ Spare
⑤ Spare	⑭ Spare
⑥ Spare	⑮ A/C Override Sense (GND)
⑦ Spare	⑯ Spare
⑧ Spare	⑰ Spare
⑨ Park Brake (GND)	⑱ Spare

J4

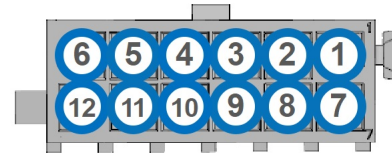

① FR Floor Ht Therm Sig.	⑦ FR Floor Ht Therm GND
② RR Floor Ht Therm Sig.	⑧ RR Floor Ht Therm GND
③ Front A/C Therm Sig.	⑨ Front A/C Therm GND
④ Mid A/C Therm Sig.	⑩ Mid A/C Therm GND
⑤ Rear A/C Therm Sig.	⑪ Rear A/C Therm GND
⑥ Bay Therm Sig.	⑫ Bay Therm GND

J5

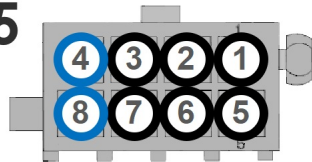

① Spare	⑤ Spare
② Spare	⑥ Spare
③ Spare	⑦ Spare
④ Ext Temp Sig.	⑧ Ext Temp GND

J6

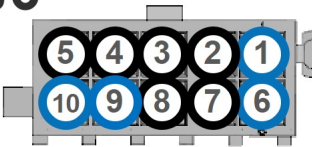

① LP Gas	⑥ LP GND
② Spare	⑦ Spare
③ Spare	⑧ Spare
④ Spare	⑨ GEN Run Signal (+12v)
⑤ Spare	⑩ RTC 12V Constant PWR

M1 HC Relay

- Bed Lift UP
- Bed Lift DOWN
- PS Fan HI
- PS Fan LO
- Bay Door Lock
- Bay Door Unlock
- Step Cover EXT
- Step Cover RET
- Door Awning EXT
- Door Awning RET
- Entry Door Lock
- Entry Door Unlock

Dip Switch Settings

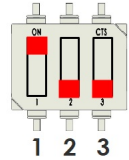

1	ON (Up)
2	OFF (Down)
3	OFF (Down)

Mid M1 Panel

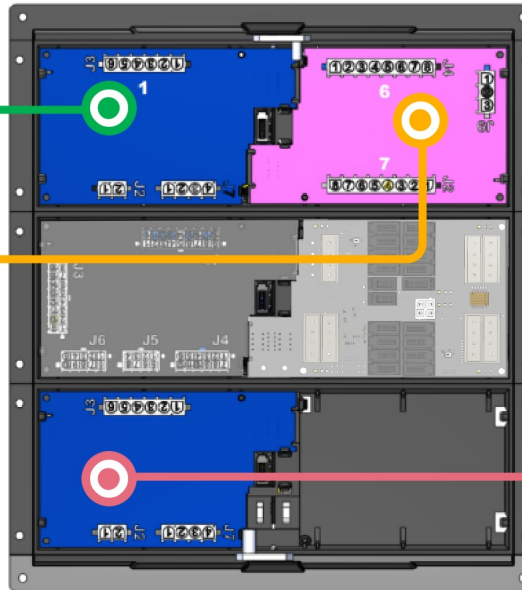

M1 High Current

- DS FR Window Awning EXT
- DS FR Window Awning RET
- DS RR Window Awning EXT
- DS RR Window Awning RET
- PS FR Window Awning EXT
- PS FR Window Awning RET
- PS RR Window Awning EXT
- PS RR Window Awning RET

M1 Low Current

- Horn (GND)
- Furnace FR
- Furnace RR
- Gen Start (GND)
- Gen Stop (GND)
- Galley SHD UP
- Galley SHD DN
- Galley NT SHD DN
- Galley NT SHD UP
- Sofa Day SHD UP
- Sofa Day SHD DN
- Sofa NT SHD DN
- Sofa NT SHD UP

i **6 Card M1 Option**
 This page and the following two pages only apply if the coach is equipped with window awnings.

RSI-12

- IGN (+12V)
- GEN Fault (+12V)
- HSE Disconnect Sense (+12V)
- Bed Lift Plunger (+12V)
- Park Brake (GND)
- Water Pump (GND)
- Entry Door Pin SW (GND)
- Merge Input (GND)
- Dash Accent ON (GND)
- Dash Accent OFF (GND)
- LP Gas
- LP GND
- Spare
- GEN Run Signal (+12v)
- RTC 12V Constant PWR
- FR Floor Heat Thermistor
- RR Floor Heat Thermistor
- Front A/C Thermistor
- Mid A/C Thermistor
- Rear A/C Thermistor
- Bay Thermistor
- Ext Temp

Dip Switch Settings

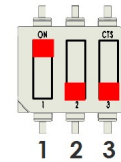

1	ON (Up)
2	OFF (Down)
3	OFF (Down)

Mid M1 Panel

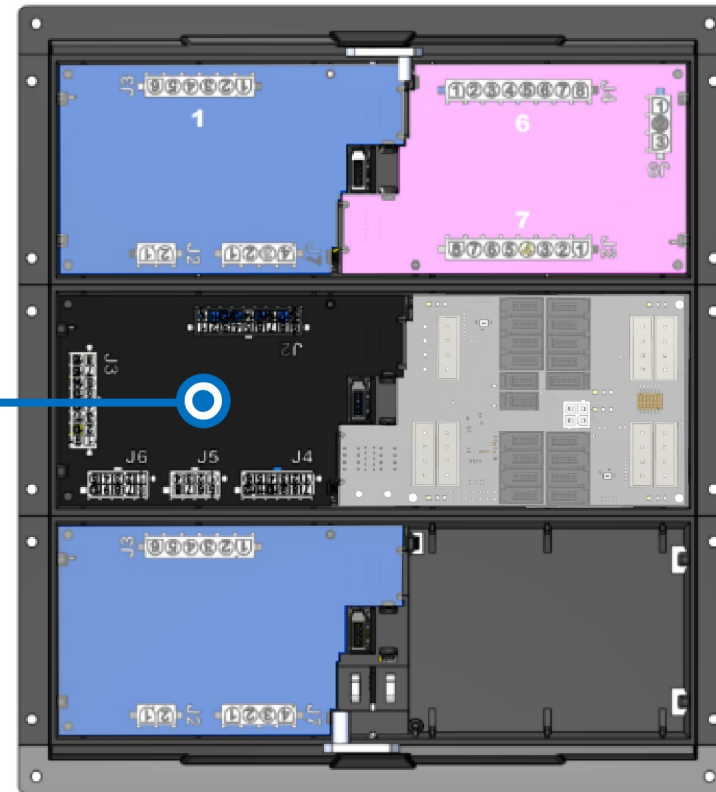

Mid M1 Panel

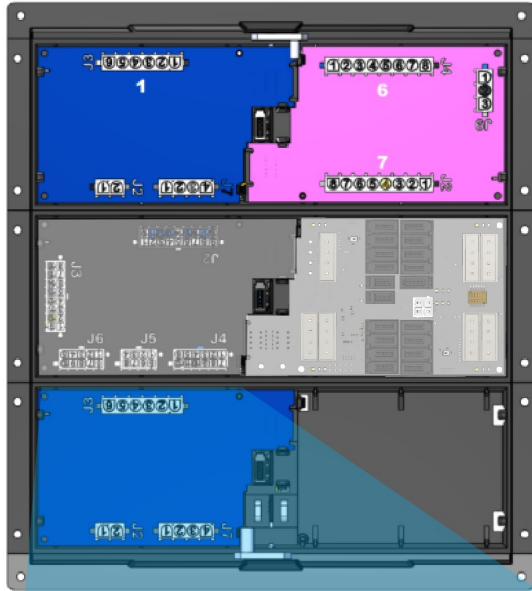

Mid M1 HC Relay (Card 5)

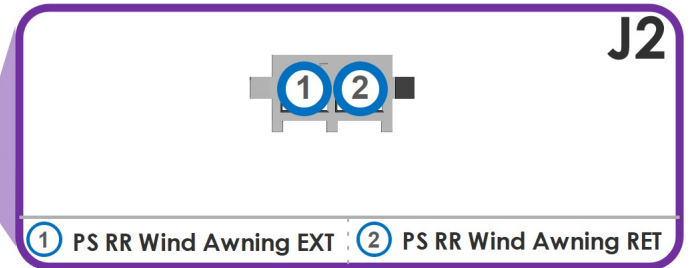
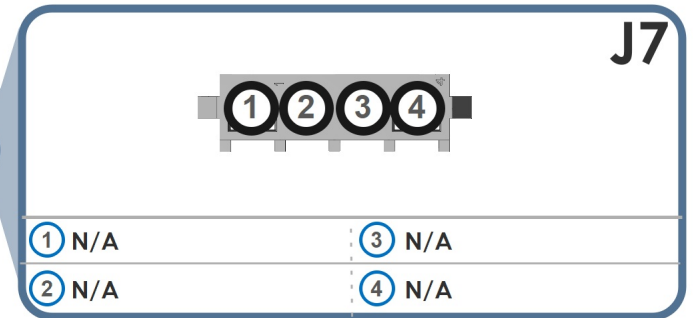
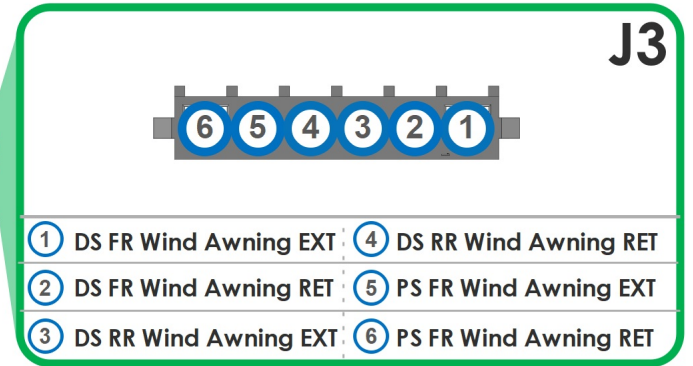
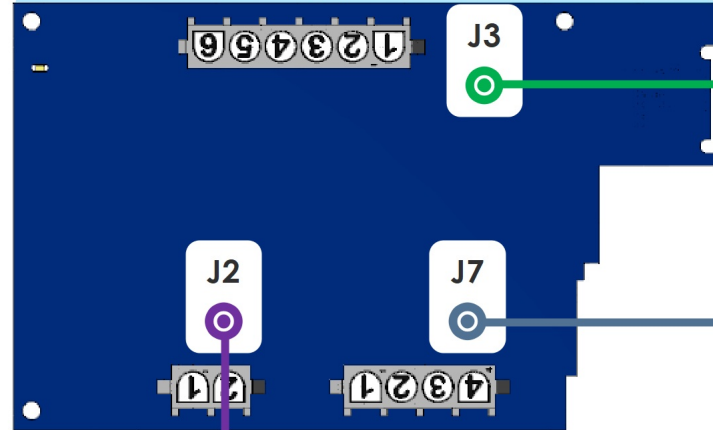

M1 Dimmer Card 1

- Entry Lt
- Main OH/Liv Lt
- PS Ceiling Lt
- DS Ceiling Lt
- Dash Accent
- FR Sconce
- RR Sconce
- DS Slide
- PS Slide
- FR Courtesy
- RR Courtesy

M1 Dimmer Card 3

- TV Accent Lt
- Closest Lt
- Floor HT FR Zone
- Floor HT RR Zone
- Fireplace Override
- Rear TV Lift Up
- Rear TV Lift Down
- Ceiling Fan HI
- Ceiling Fan LO

Dip Switch Settings

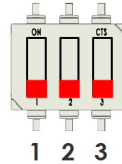

- | | |
|---|------------|
| 1 | OFF (Down) |
| 2 | OFF (Down) |
| 3 | OFF (Down) |

Rear M1 Panel

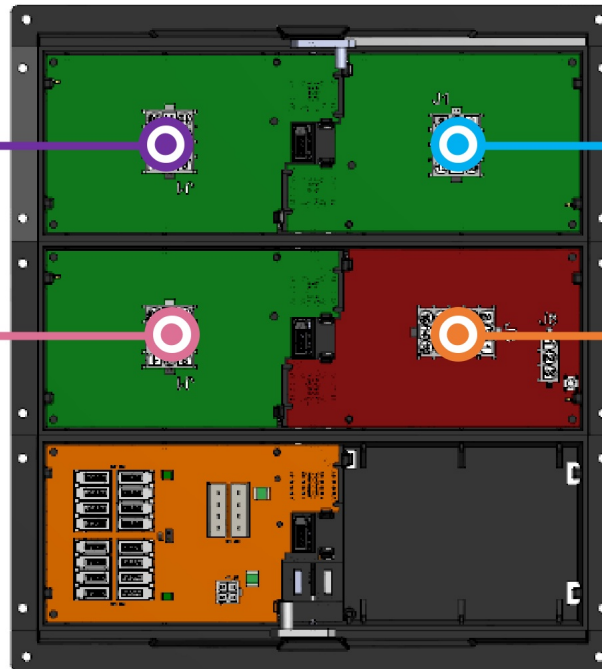

M1 Dimmer Card 2

- Bedroom Ceiling Lt
- Bed Accent Lt
- FR Accent 1
- FR Accent 2
- Task Lt
- Mid Bath Lt
- Mid Bath Vanity Lt
- Rear Bath Lt
- Rear Bath Vanity Lt
- FR Bed Reading
- RR Bed Reading
- RR Accent

M1 Breaker Card 4

- Basement 12v PWR/Ext TV 12v
- SEELEVEL
- Front Furnace
- Prox. AC RLY SW/Galley Motion Lt
- Switcher/IR Blaster
- Vent Fan PWR
- Rear Furnace
- Mid Toilet
- Front Pass Slide/Dinette SHD
- Bed Slide/Wall USB
- Truma Water Heater
- FR/RR TV Lift

Rear M1 Panel

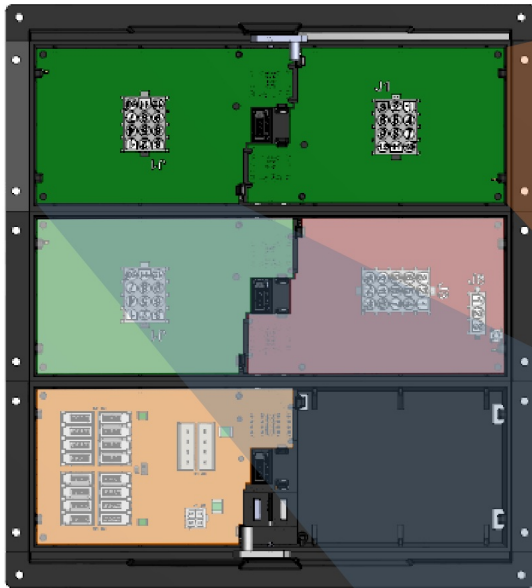

M1 Dimmer (Card 2)

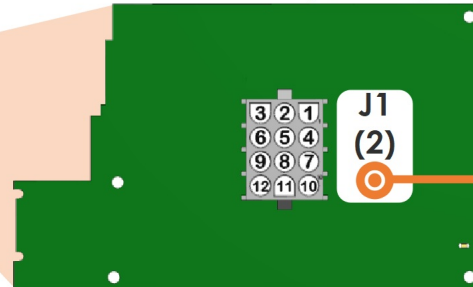

M1 Dimmer (Card 1)

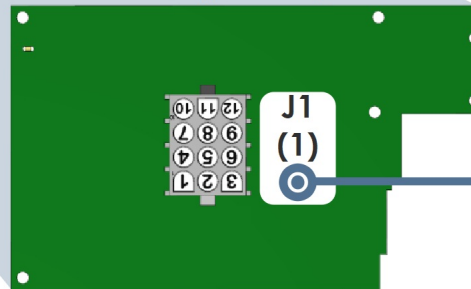

J1 (2)

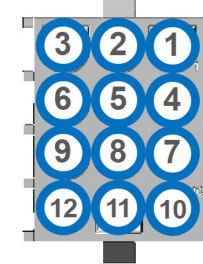

- | | |
|----------------------|-----------------------|
| 1 Bedroom Ceiling Lt | 7 Mid Bath Vanity Lt |
| 2 Bed Accent | 8 Rear Bath Lt |
| 3 FR Accent 1 | 9 Rear Bath Vanity Lt |
| 4 FR Accent 2 | 10 FR Bed Reading Lt |
| 5 Task Lt | 11 RR Bed Reading Lt |
| 6 Mid Bath Lt | 12 RR Accent |

J1 (1)

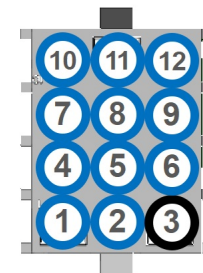

- | | |
|------------------|----------------|
| 1 Entry Lt | 7 FR Sconce |
| 2 Main OH/Liv Lt | 8 RR Sconce |
| 3 Spare | 9 DS Slide |
| 4 PS Ceiling Lt | 10 PS Slide |
| 5 DS Ceiling Lt | 11 FR Courtesy |
| 6 Dash Accent | 12 RR Courtesy |

Rear M1 Panel

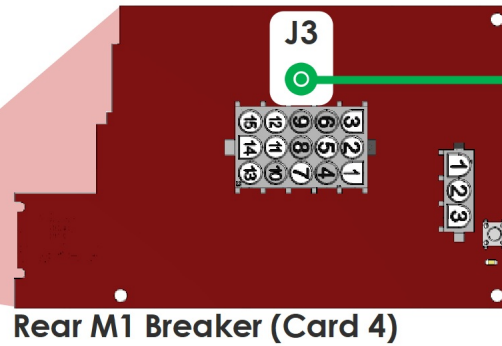
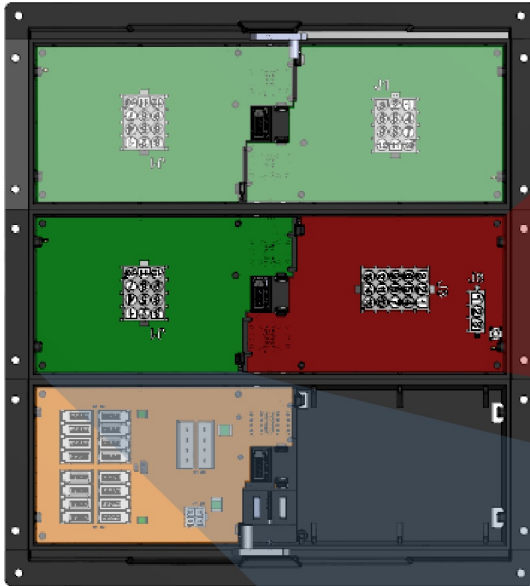

Rear M1 Breaker (Card 4)

15	12	9	6	3
14	11	8	5	2
13	10	7	4	1

1 FR/RR TV Lift	9 Prox. AC RLY SW/Gasley Motion Lt
2 Basement 12v PWR/Ext TV 12v	10 Front Pass Slide/Dinette SHD
3 SEELEVEL	11 N/A
4 Truma Water Heater	12 Switcher/IR Blaster
5 N/A	13 Mid Toilet
6 Front Furnace	14 Rear Furnace
7 Bed Slide/Wall USB	15 Vent Fan Power
8 N/A	

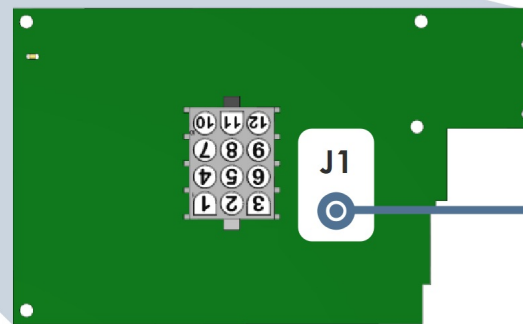

Rear M1 Dimmer (Card 3)

10	11	12
7	8	9
4	5	6
1	2	3

1 TV Accent Lt	7 Spare
2 Closet Lt	8 Fireplace Override
3 Spare	9 Rear TV Lift Up
4 Spare	10 Rear TV Lift Down
5 Floor HT FR Zone	11 Ceiling Fan HI
6 Floor HT RR Zone	12 Ceiling Fan LO

1

Dimmer Card 1

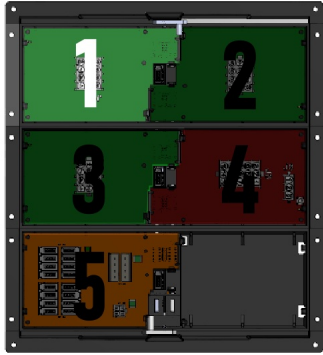

Rear M1 Panel

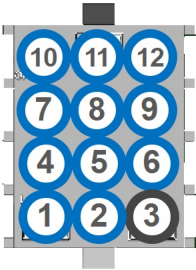

Outputs

① Entry Lt	⑦ FR Sconce
② Main OH/Liv Rm	⑧ RR Sconce
③ Spare	⑨ DS Slide
④ PS Ceiling Lt	⑩ PS Slide
⑤ DS Ceiling Lt	⑪ FR Courtesy
⑥ Dash Accent	⑫ RR Courtesy

2

Dimmer Card 2

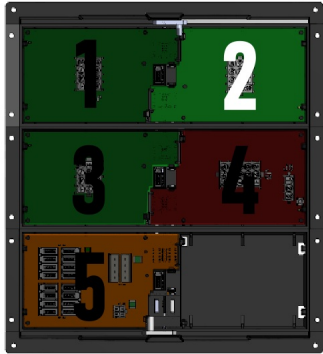

Rear M1 Panel

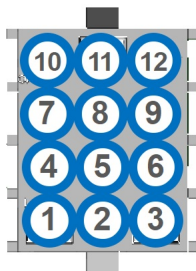

Outputs

① Bed Ceiling Lt	⑦ Mid Bath Vanity Lt
② Bed Accent	⑧ Rear Bath Lt
③ FR Accent 1	⑨ Rear Bath Vanity Lt
④ FR Accent 2	⑩ FR Bed Reading Lt
⑤ Task Lt	⑪ RR Bed Reading Lt
⑥ Mid Bath Lt	⑫ RR Accent

3

Dimmer Card 3

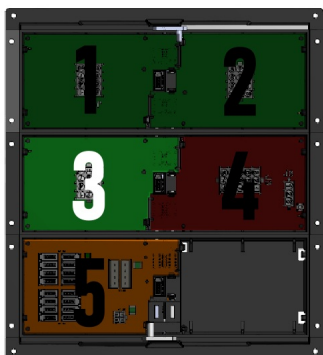

Rear M1 Panel

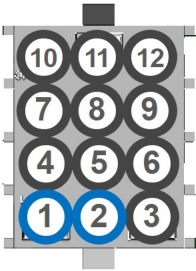

Outputs

① TV Accent Lt	⑦ Spare
② Closet Lt	⑧ N/A
③ Spare	⑨ N/A
④ Spare	⑩ N/A
⑤ N/A	⑪ N/A
⑥ N/A	⑫ N/A

Front M1 Panel

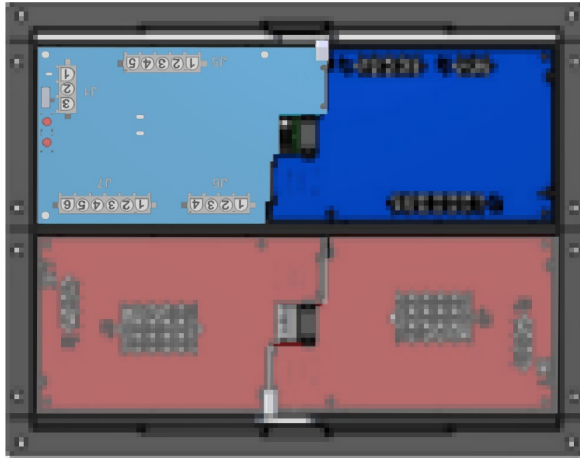

M1 HC Relay

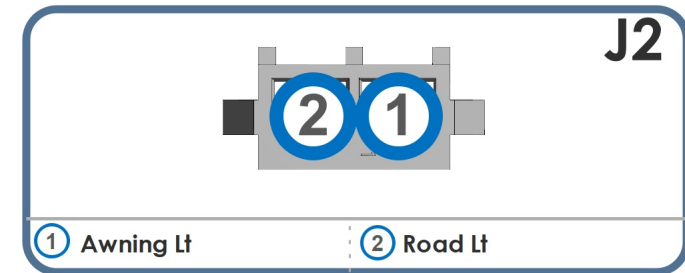
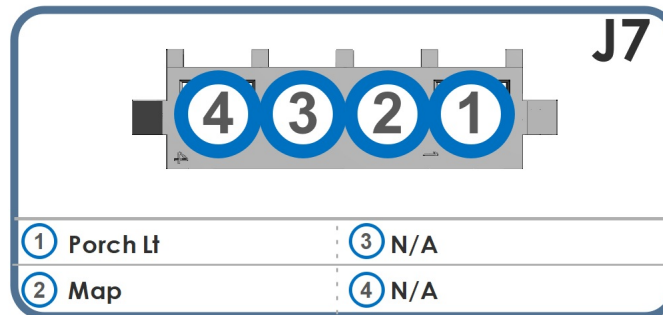
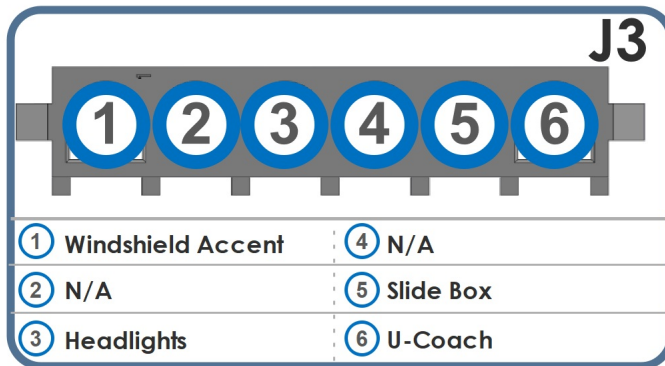
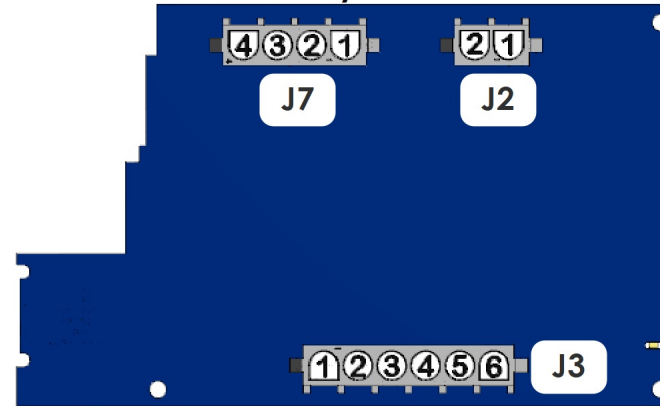

Emergency Override
 Park brake and ignition must be on for slides to operate.
 In case of a system failure, use manual overrides on the slide card to operate slides.
 Engage overrides using a pen or other pointed object.

Ignition Switch

Park Brake Switch

RSI-12

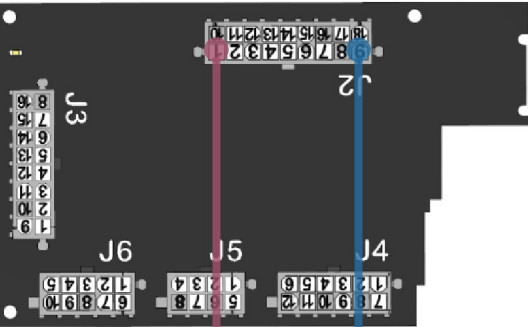

M1 Slide Card

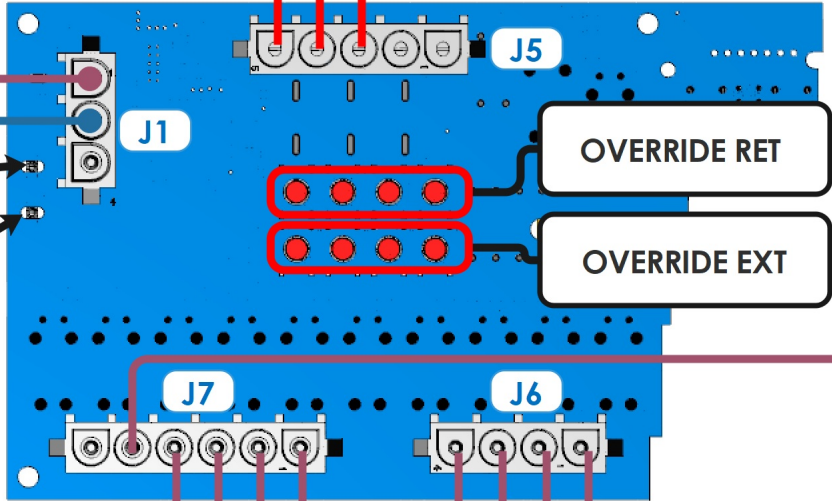

- Slide Breakers**
- ⑤ Slide Breaker #3
 - ④ Slide Breaker #2
 - ③ Slide Breaker #1

- Hydraulic Pump**
- Power Output
- ⑤ Hydraulic Pump

Awnings Ready LED

Slides Ready LED

OVERVERRIDE RET

OVERVERRIDE EXT

- Rear Slide Outputs**
- D/S RR Slide RET ④
 - D/S RR Slide EXT ③
 - P/S RR Slide RET ②
 - P/S RR Slide EXT ①

- Front Slide Outputs**
- ① P/S FR Slide EXT
 - ② P/S FR Slide RET
 - ③ D/S FR Slide EXT
 - ④ D/S FR Slide RET

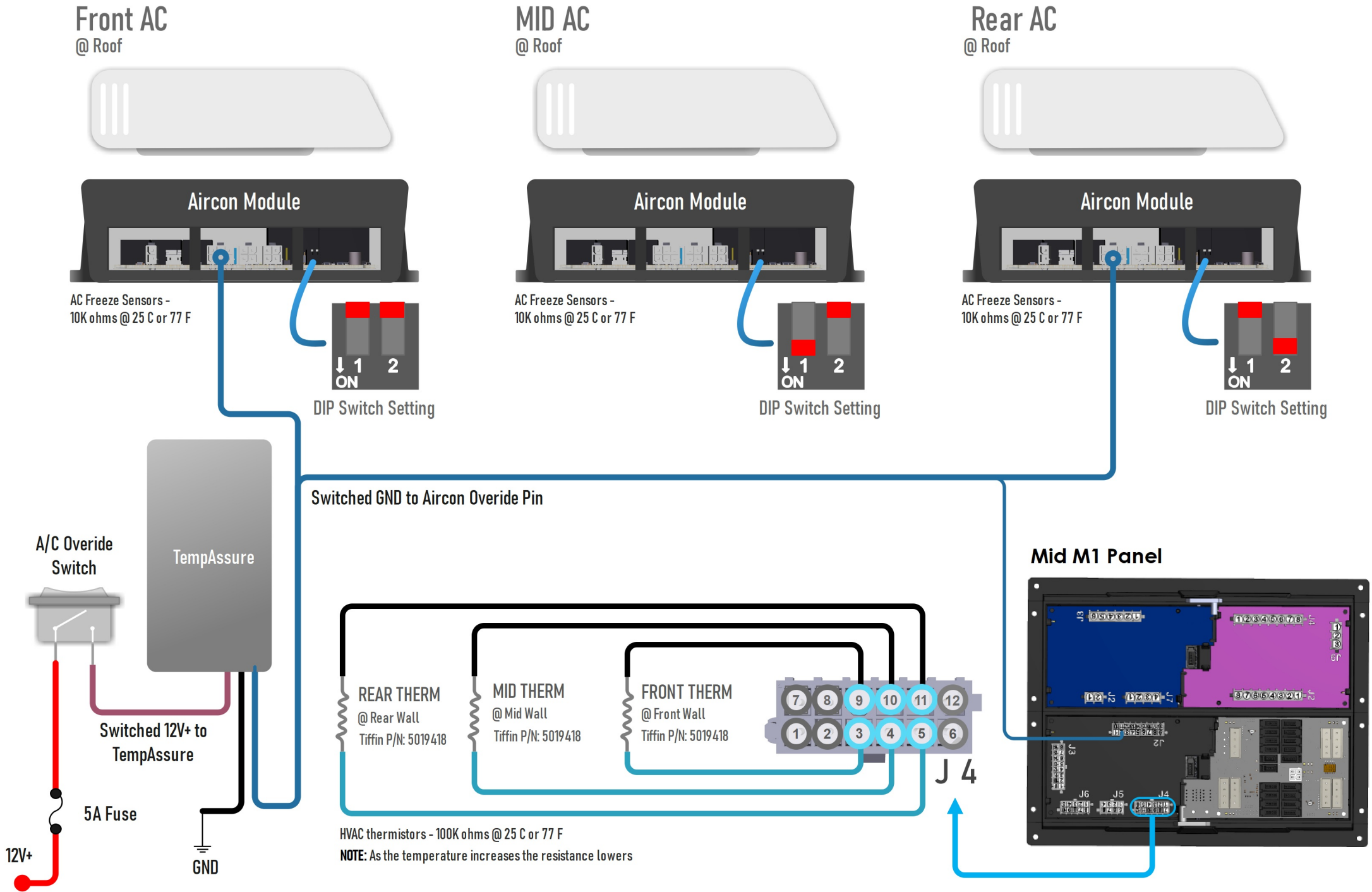

Mid M1 Panel

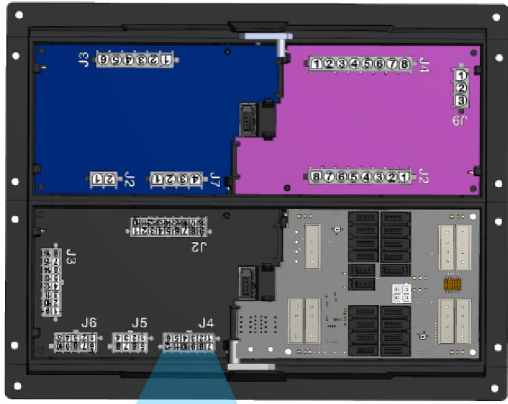

120V BREAKER PANEL @Rear Closet

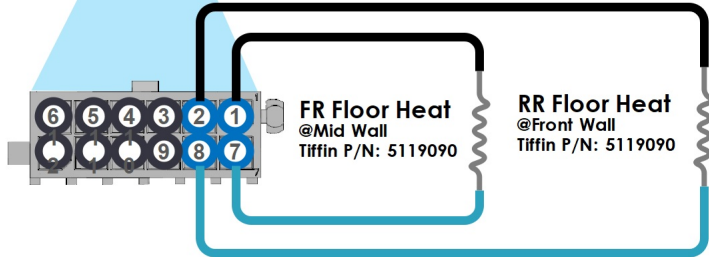
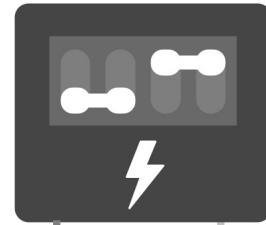

Rear M1 Panel Card 3

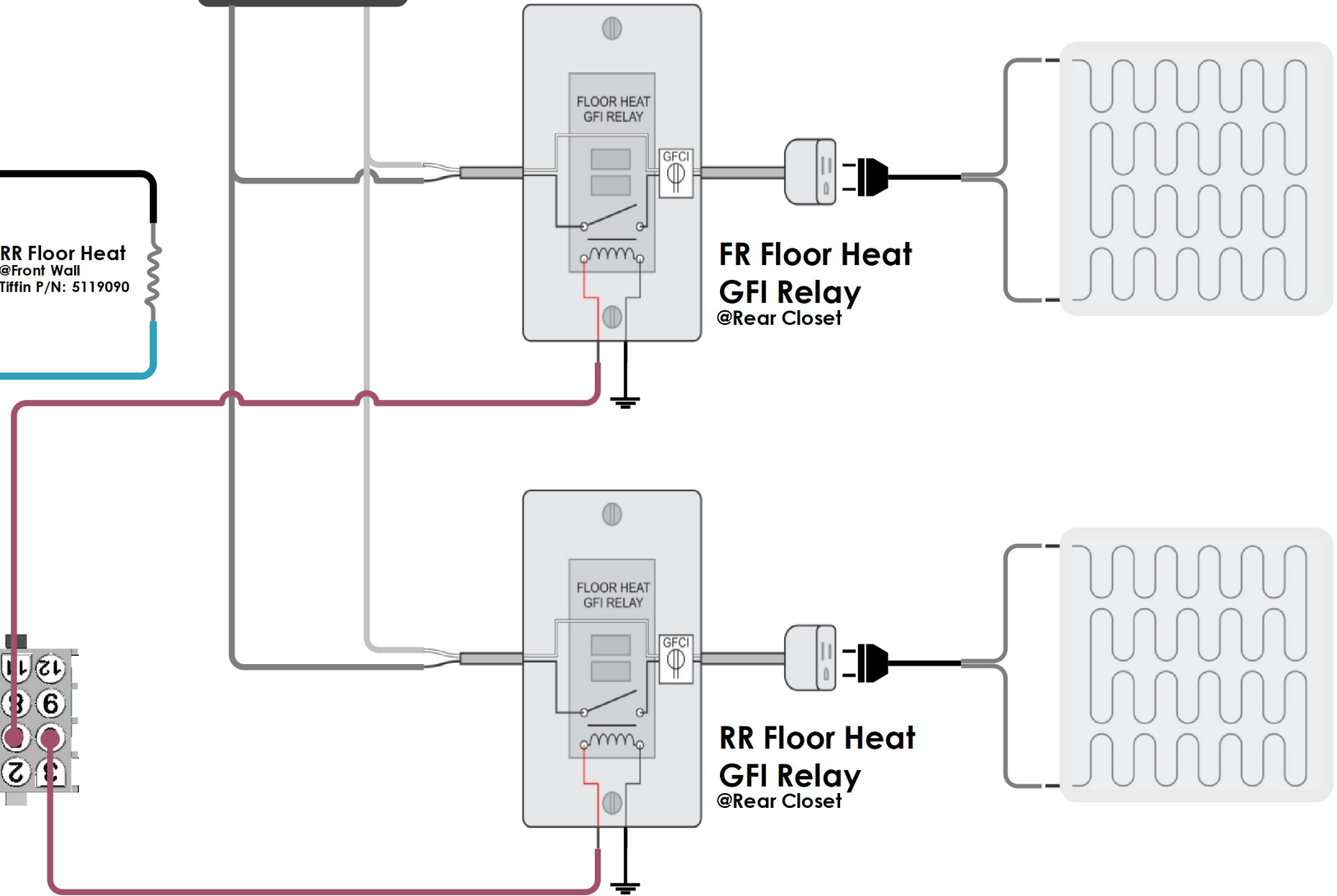
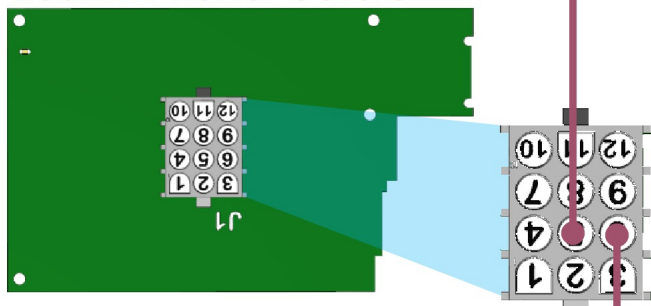

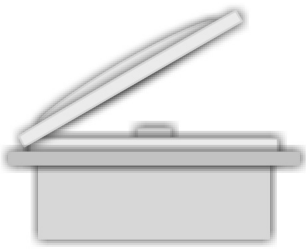

VENT FAN

@ Galley

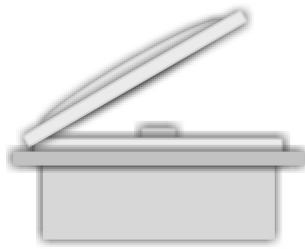

VENT FAN

@ Mid Bath

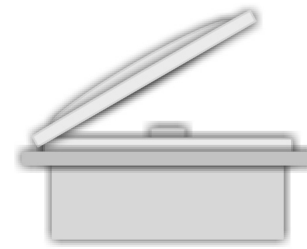

VENT FAN

@ Rear Bath

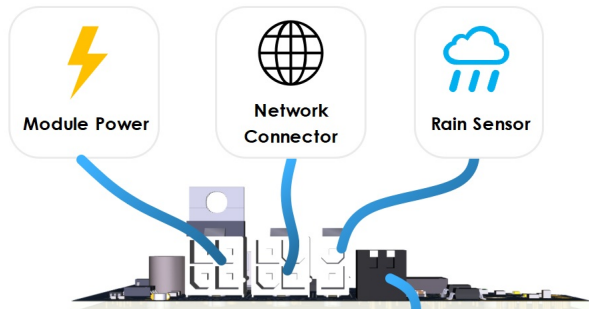

MAXXFAN VENT FAN CONTROLLER

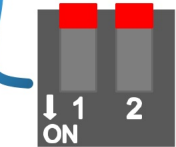

DIP Switch Setting

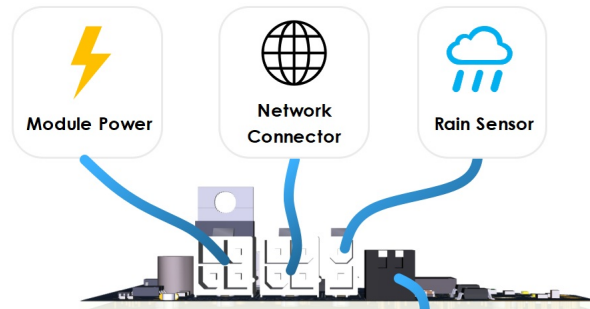

MAXXFAN VENT FAN CONTROLLER

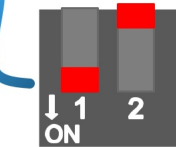

DIP Switch Setting

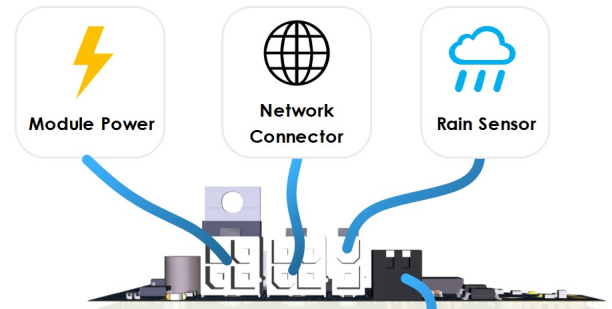

MAXXFAN VENT FAN CONTROLLER

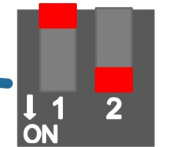

DIP Switch Setting



M1 Rear Panel

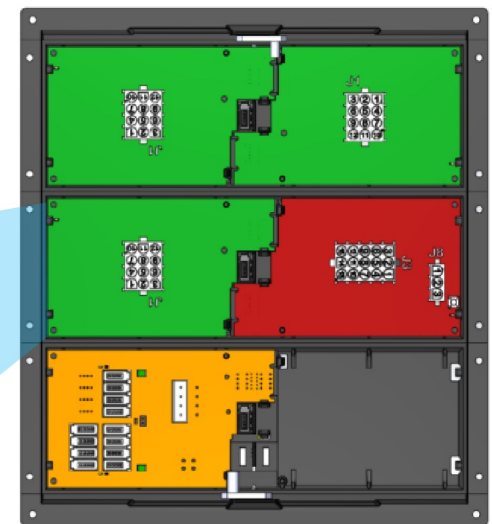

M1 Dimmer (Card 3)

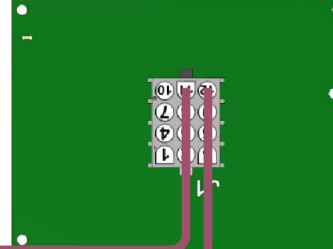

Ceiling Fan
@Bedroom

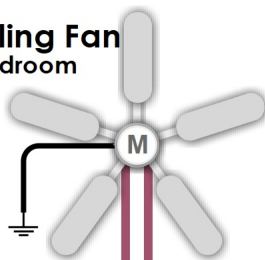

Fan Low Resistor



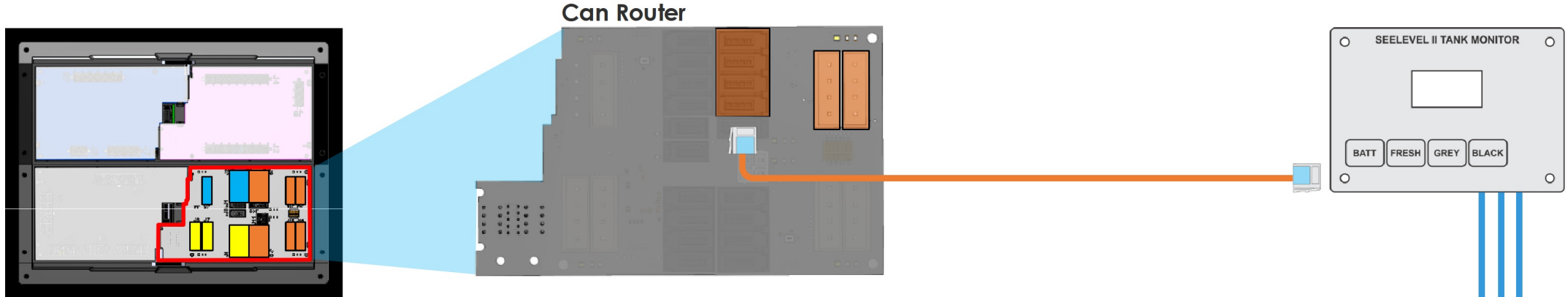

Mid M1 Panel



Seelevel Tank System

This coach is equipped with a Seelevel Tank sensing system 1 made by Garnet Industries. This tank system receives data from the strip sensors on the tank. The Seelevel monitor then transmits this data across the RV-C network.

The Spyder System detects the tank information broadcast by Seelevel. This information is displayed on all Spyder displays where tank information can be found.

If the tank information displayed on a Spyder System is incorrect the issue is not related to the Spyder System itself. The Spyder System only displays information broadcast by Seelevel.

If no tank information is present the Seelevel monitor may be offline.

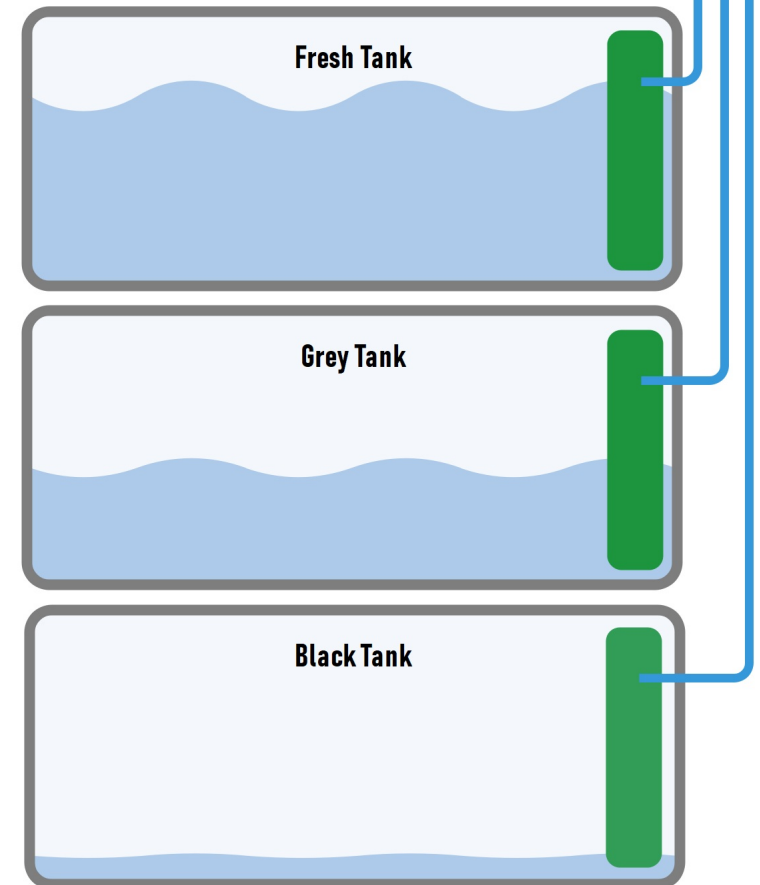

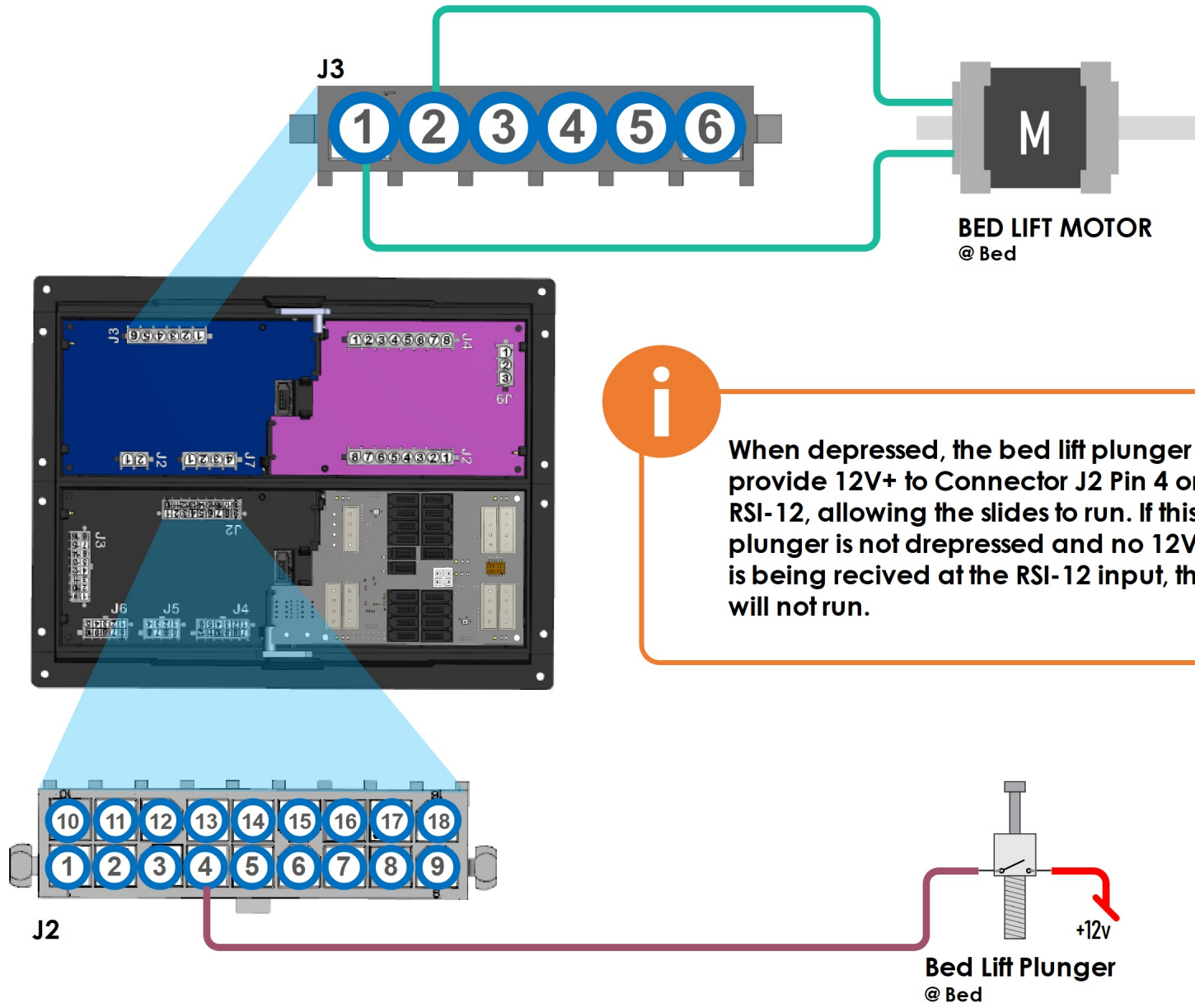

i When depressed, the bed lift plunger will provide 12V+ to Connector J2 Pin 4 on the RSI-12, allowing the slides to run. If this plunger is not depressed and no 12V+ signal is being received at the RSI-12 input, the slides will not run.

Trouble Shooting

This information is only applicable to coaches with a MoRyde TV Lift. The module above is an HCR-15 and is responsible for providing reverse polarity output to the MoRyde TV Lift Motor.

If the TV lift is not raising or lowering check to ensure the NET LED on the HCR-15 is on solid green. If it is flashing or off completely there is an issue with network connectivity. If the module is online (solid green LED) and the TV lift still fails to work, use a multimeter to probe the connector.

Insert one probe into 1A and the other probe into 1B. Correct function would have the module output 12V+ in one direction and ground in the other direction. If this is not occurring, please call Spyder Controls.

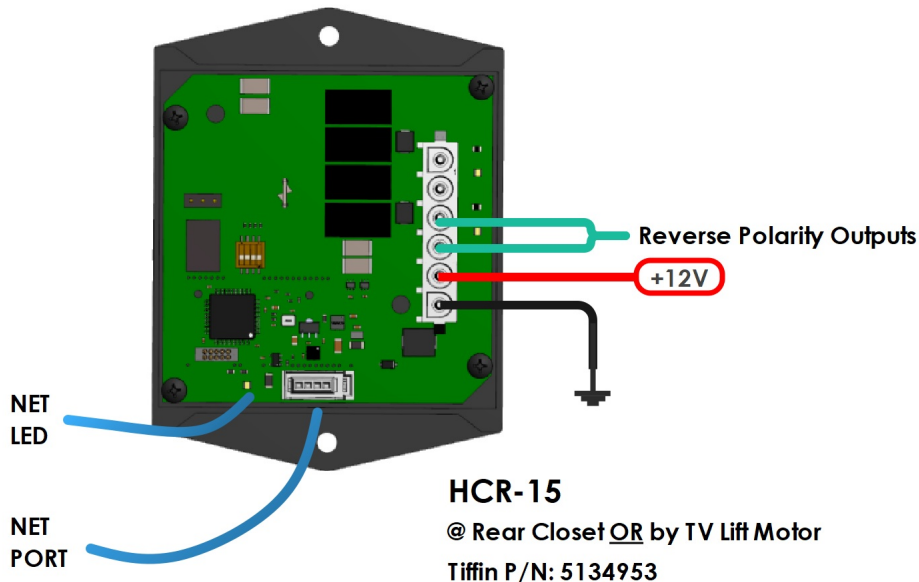
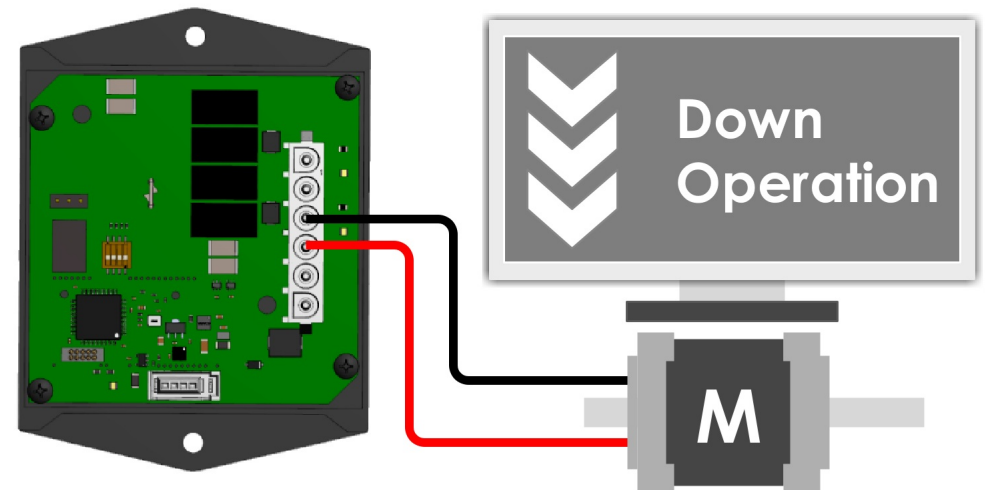
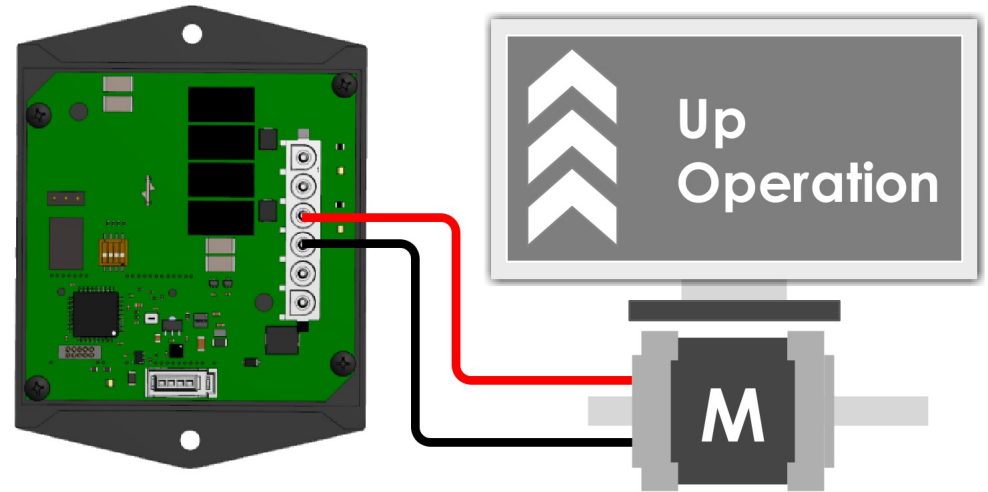

Trouble Shooting

The module below is an HCR-15 and is responsible for providing 12V output to the TV lift motor.

If the TV lift is not raising or lowering check to ensure the NET LED on the HCR-15 is on solid green. If it is flashing or off completely there is an issue with network connectivity. If the module is online (solid green LED) and the TV lift still fails to work, use a multimeter to probe the connector.

To troubleshoot this further, please contact Spyder Controls.

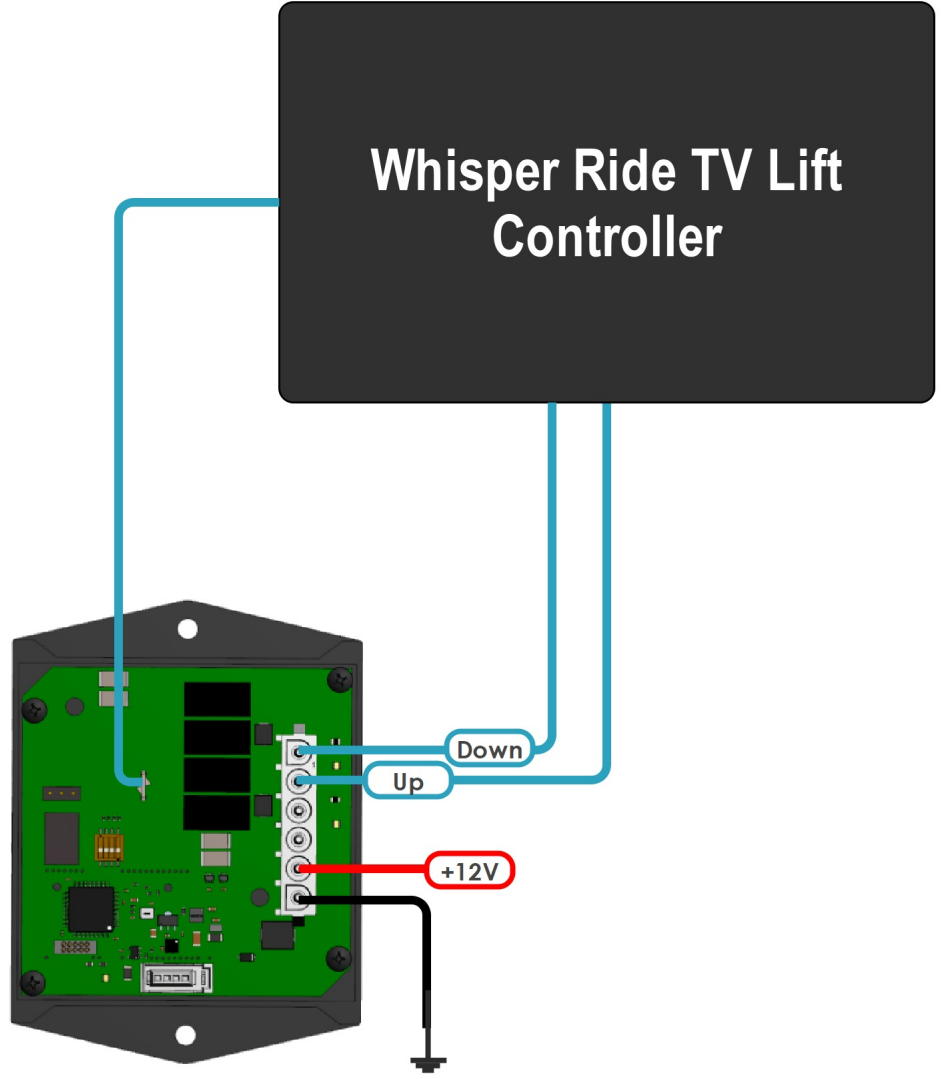
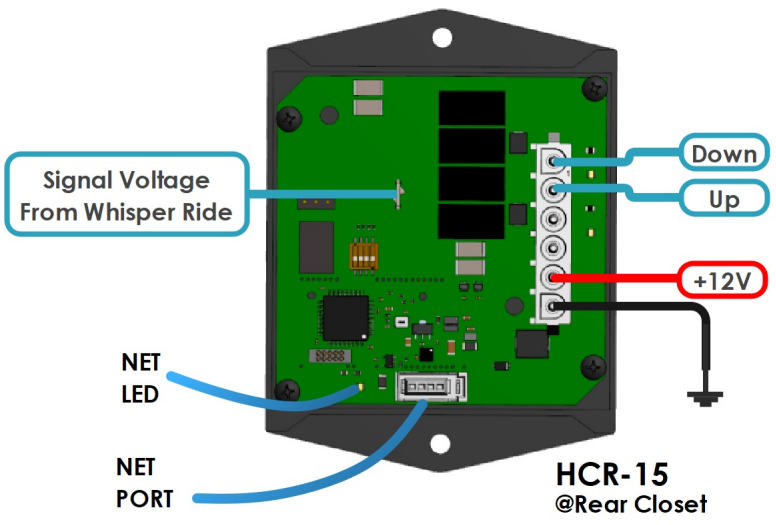

Location Setting

The location setting for the HCR 15 can be changed via connector J5.

Front TV Lift

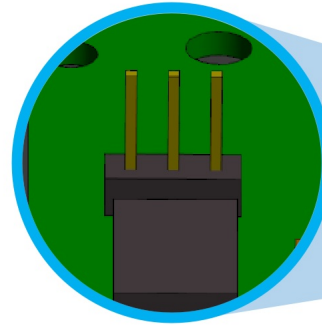

HCR 15

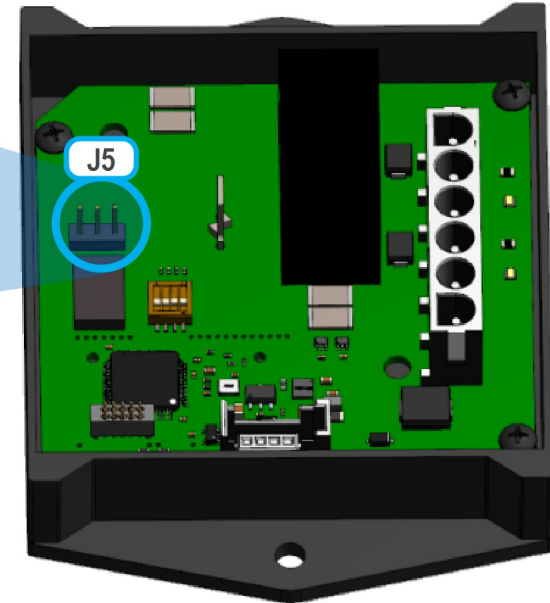

Rear TV Lift

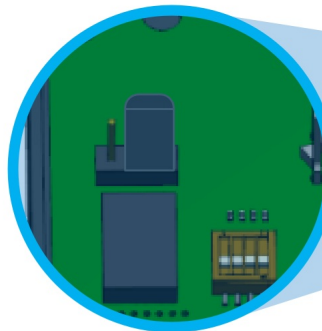

Mid M1 Panel

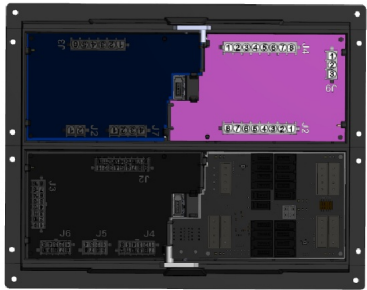

M1 Low Current
@M1 Mid Panel

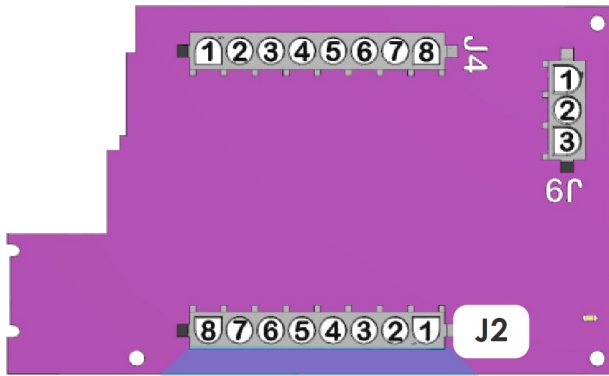

J2 (M1 Low Current)

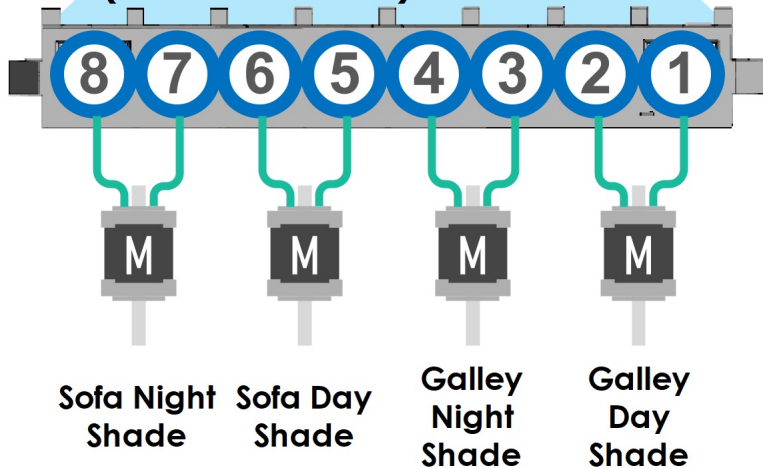

Dash Shade Module

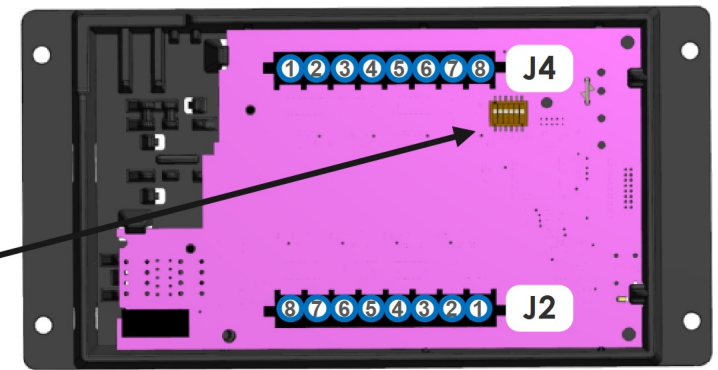

Dip Switch Setting

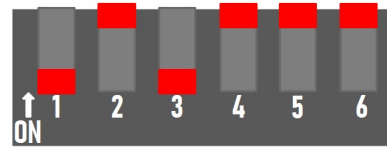

J4

(Shade Module)

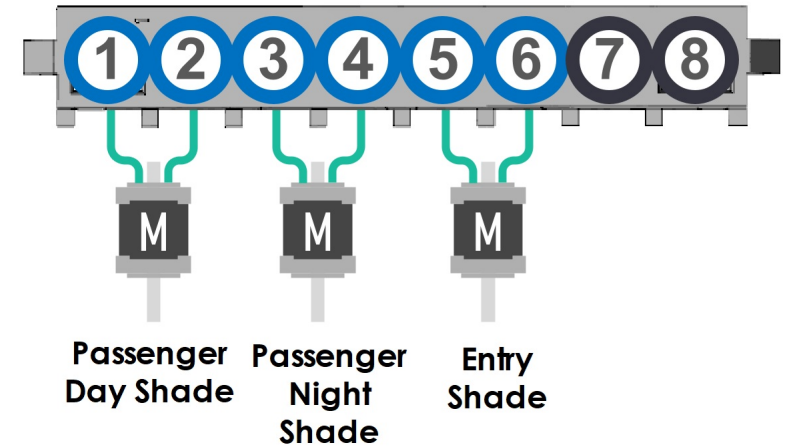

J2

(Shade Module)

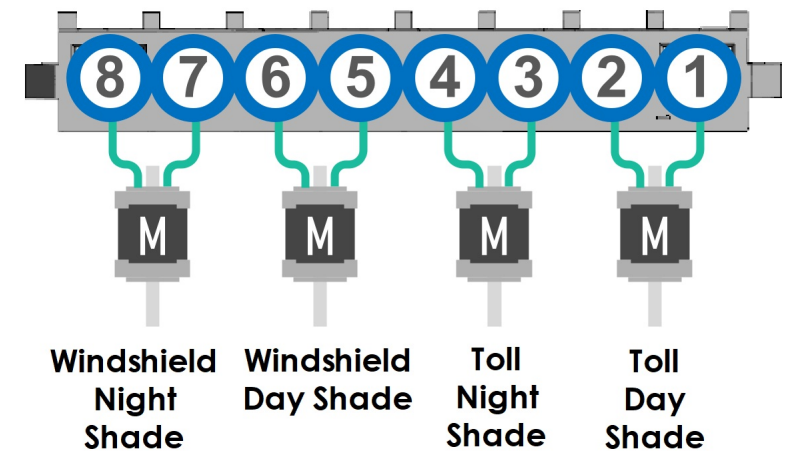

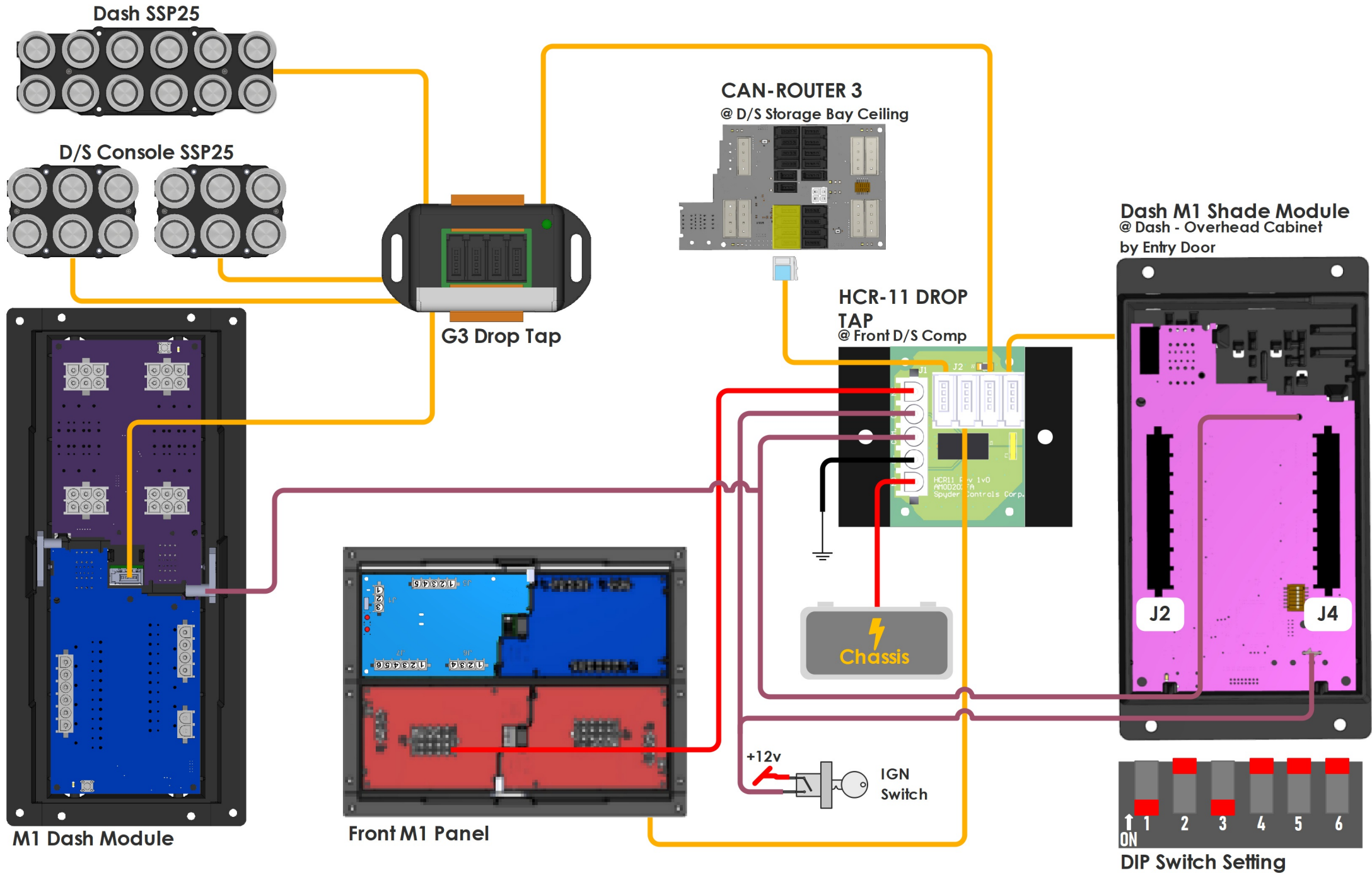

Front Shade Module

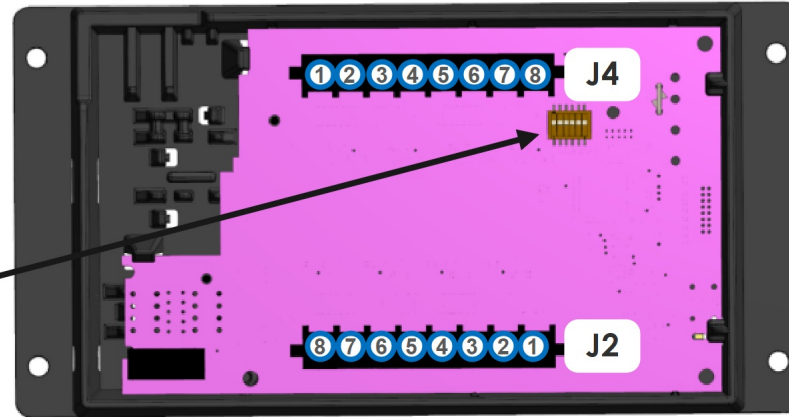

Dip Switch Setting

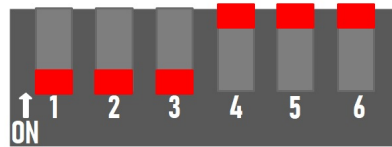

J4

(Front Shade Module)

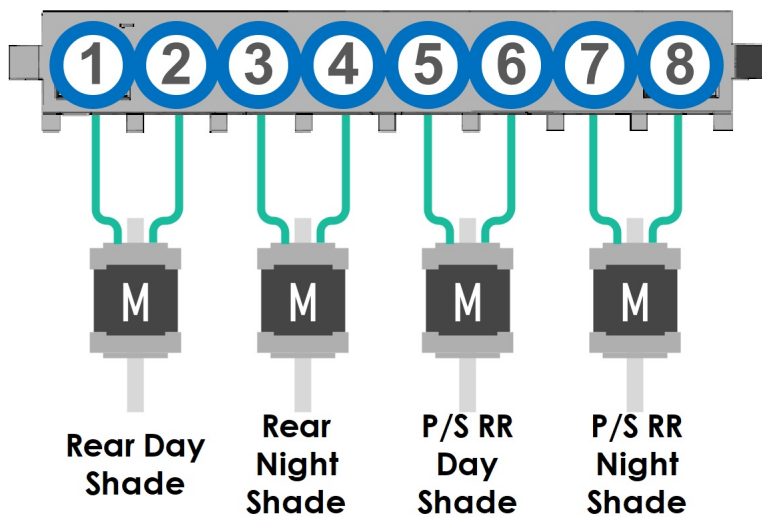

J2

(Front Shade Module)

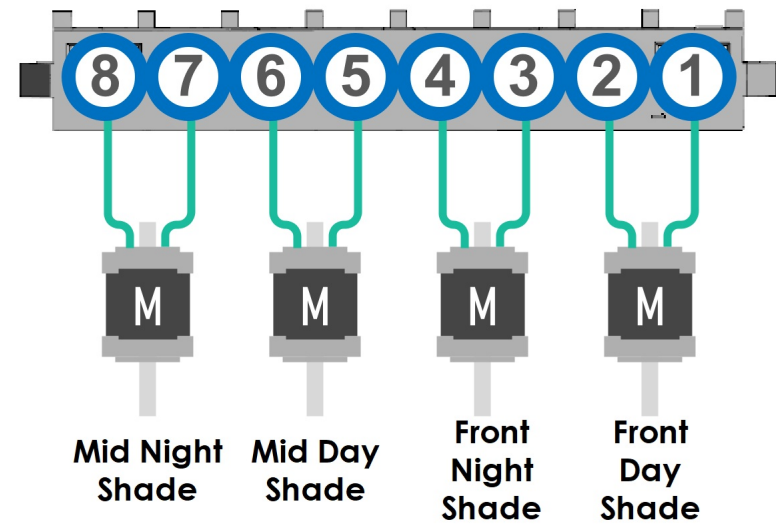

RSI-12
@Mid M1 Panel

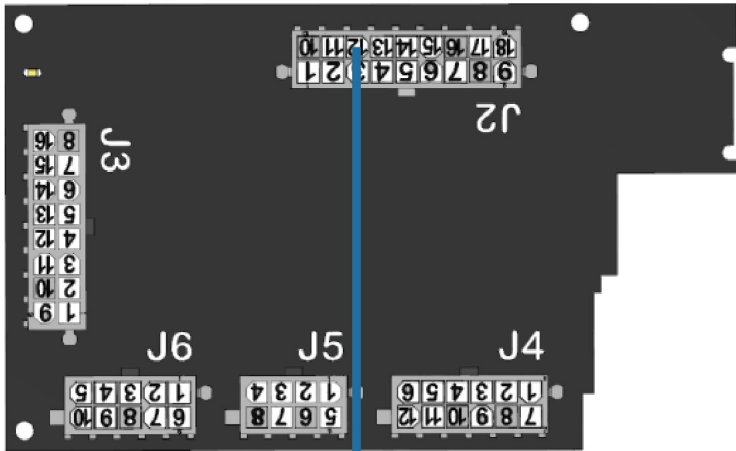

COACH RUNNING INPUT

Depending on the chassis used in the coach the coach running input will either come from the engine (switched GND) or from the ignition (switched 12V+)



DCD Panel

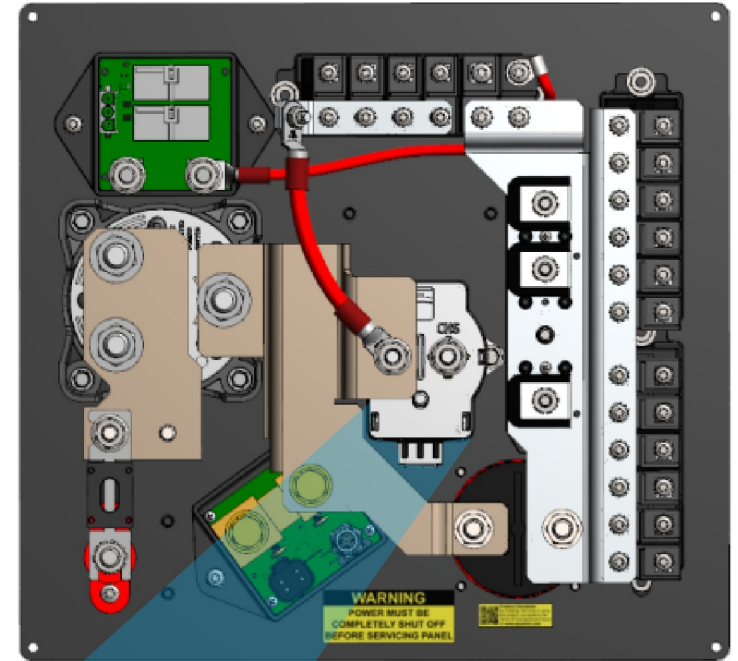

MERGE SOLENOID
@ Back of DCD

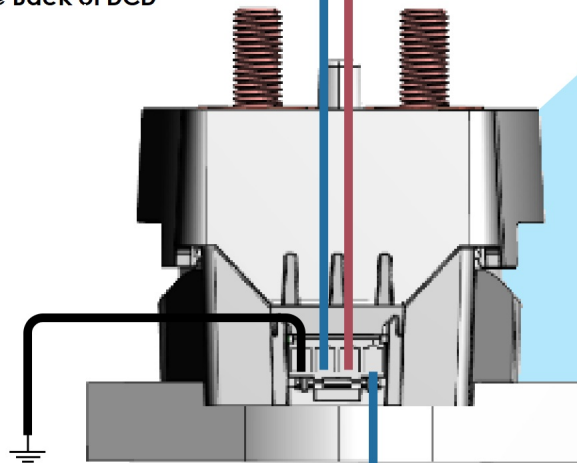

Auto / Manual Merge Input (GND)

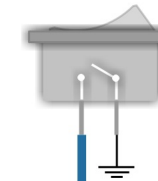

Manual Merge
Override Switch
@ Dash

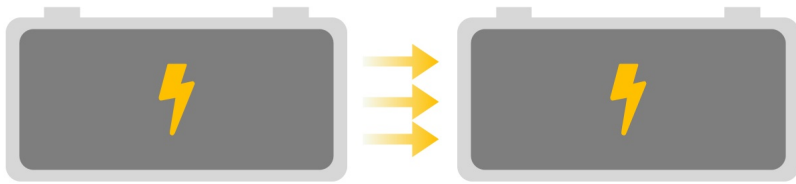
**CHASSIS BATTERY**

⚡ 13.3V+ Or Higher

🕒 30 Seconds

🔑 🚗 V+

HOUSE BATTERY**MERGE LOGIC - CHASSIS CHARGING HOUSE**

The merge solenoid will engage if the following conditions are present:

- Engine run or ignition signal is present and chassis voltage is above 13.3V (charging) for 30 seconds.

The merge solenoid will disengage under either of the following conditions

- Engine run or ignition signal is removed
- Chassis voltage drops below 12.6V for more than 30 seconds (unmerge until engine is started again)

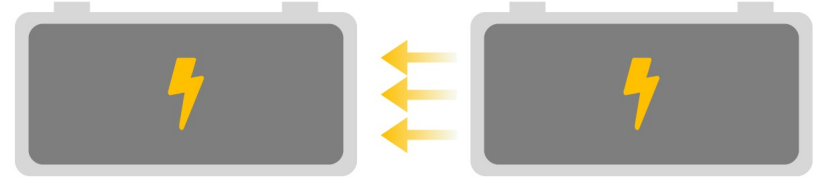
**CHASSIS BATTERY**

⚡ 12.4V+ Or Lower

🕒 30 Seconds

V+

HOUSE BATTERY

⚡ 12.5V+ Or Higher

🕒 30 Seconds

V+

MERGE LOGIC - HOUSE CHARGING CHASSIS

The merge solenoid will engage if the following conditions are present:

- House voltage is above 12.5V (charging) and chassis voltage is below 12.4V (low battery voltage) for 30 seconds

The merge solenoid will disengage under either of the following conditions:

- House voltage drops below 12.2V for more than 30 seconds, OR
- 60 minutes timed battery merge period expires. Re-merge will occur again if the merge conditions are still present

**Merge Logic - Note**

The voltages used in this spec are what are read directly at the merge solenoid which is installed at the DCD panel and may vary from the voltages displayed on the LCD screens for general informational purposes

What is EMS?

The EMS or Energy Management System is designed to keep your coach from tripping the shore or generator breaker while using shore or generator power.

How does it work?

The EMS works by allowing or disallowing AC power to specific loads. Keep in mind that not all AC loads are controlled by the EMS. All loads that can be controlled by EMS are displayed in the center column of the Power Page on the main hall LCD. EMS must be enabled to view this page.

What does "SHED" mean?

When EMS has disallowed AC power to a load we consider that load "SHED". This simply means that there currently is not enough AC power available for the load and the EMS will provide power when it is available.

10" Pro LCD



Loads that can "SHED"

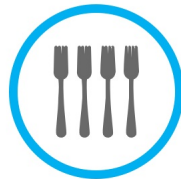

Dishwasher



Washer / Dryer



Engine Preheat



All AC Units

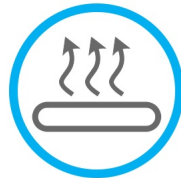

All Floorheat



Fireplace



TRC TRANSFER SWITCH

The TRC Transfer switch provides the AC power readings found on the power page.

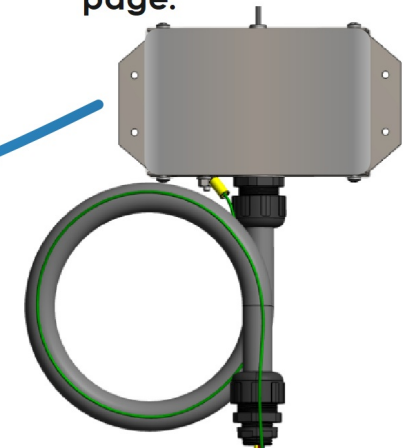

ACR3

The ACR3 allows the EMS to "SHED" the washer/dryer, dishwasher, fireplace and the engine preheat when required.

IF ENABLED INVERTER ASSIST WILL ACTIVATE IF THE FOLLOWING CONDITIONS ARE TRUE

Inverter assist is a state in which power is temporarily drawn from the batteries to keep EMS loads from shedding.

1

SHORE OR GENERATOR POWER IS AVAILIABLE

2

THE CHARGER IS IN FLOAT MODE
(BATTERIES ARE CLOSE TO FULL CHARGE)

3

THE CHARGE RATE HAS BEEN REDUCED

4

A NON-EMS INVERTED LOAD IS ACTIVATED,
SUCH AS THE MICROWAVE

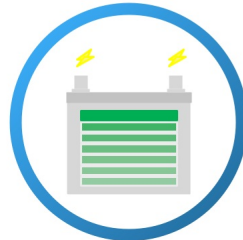

Batteries close to full

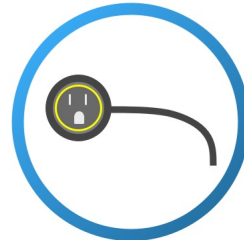

Connected to Shore Power or Gen Charging

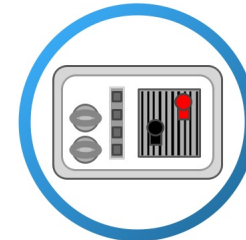

Charger in Float

=

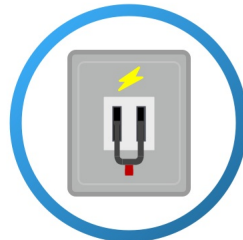

Close to Shore / Gen Breaker Max

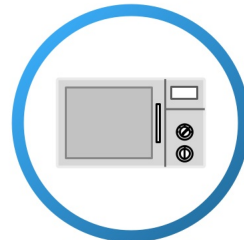

Non-EMS Inverted Load Activated

!

If the conditions above are true. To keep any EMS load from shedding the inverter will go from passthrough to inverting to temporarily invert for 5 minutes. Please note inverter assist will temporarily decrease your battery voltage. This is normal the voltage will stabilize relatively quickly once the inveter assist period has expired. Please note inverter assist can only occur once every charge cycle. Therefore, the coach will not frequently be in inverter assist mode.

!

Inverter assist can be enabled or disabled from the inverter settings page. On you main LCD navigate to the power page > inverter settings > advanced battery settings > inverter assist.

To Replace The Battery

To replace the battery firmly grasp the outside edge of the wireless rocker switch. Pull to the left or right until the switch snaps off the wall. Use a pen or other thin object to push the coin cell out of the retaining clip. Insert new battery with the + symbol facing upwards, ensure battery is seated into retaining clip all the way.

Use the up arrows on the back of the switch panel to orientate placement back onto the mounting bracket. Snap the wireless rocker switch back into place.

Test the switch and dispose of the old battery responsibly.

WARNING
 ONLY REPLACE THE COIN CELL BATTERY WITH A CR2032. DOING OTHERWISE WILL VOID THE PANEL WARRANTY AND COULD DAMAGE THE PANEL



Insert Battery with + sign facing up.

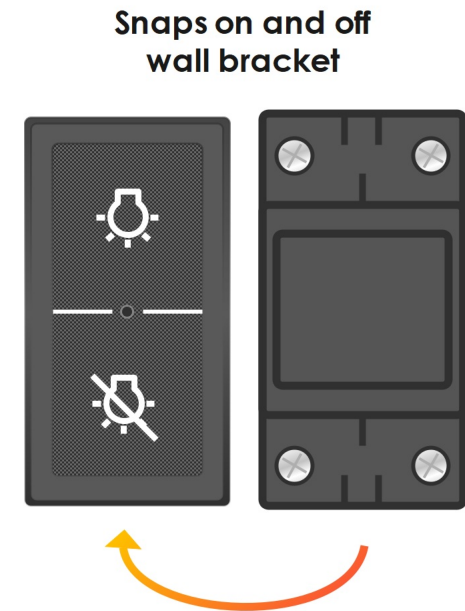

A green LED will turn on when a button is pressed. This is the transmit LED and confirms that the switch panel is transmitting information. This LED will flash occasionally indicating the switch panel is transmitting it's battery status.

Not Transmitting

Transmitting

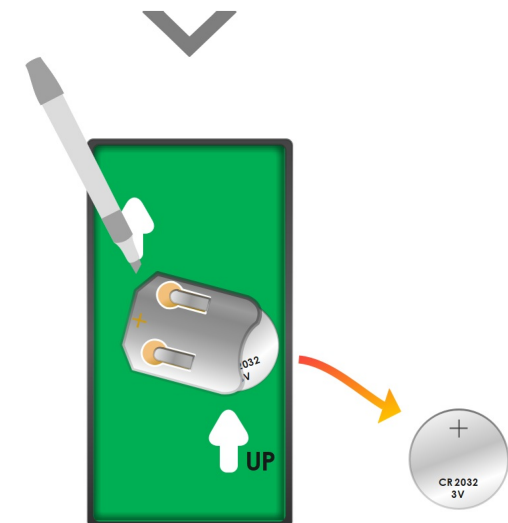
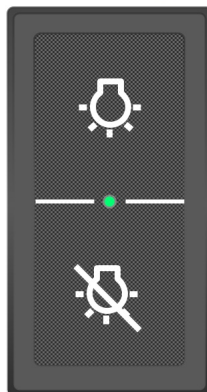
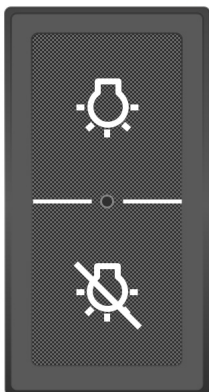

Mid M1 Panel

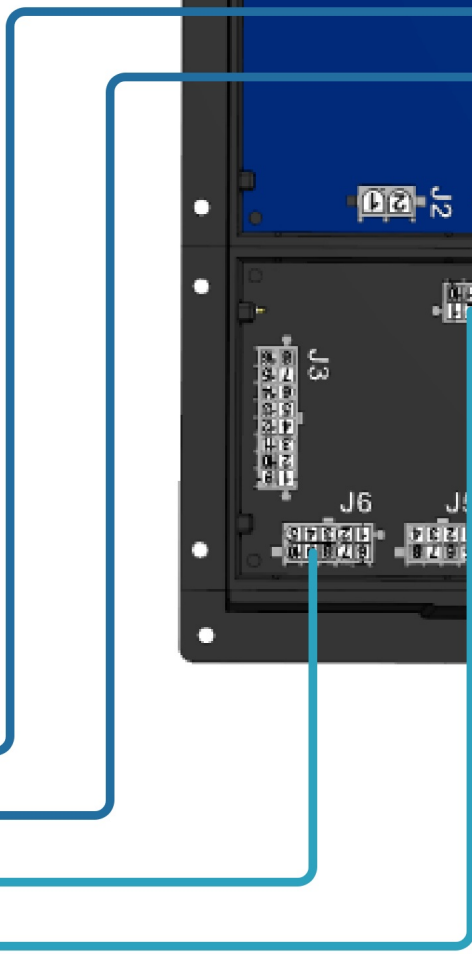
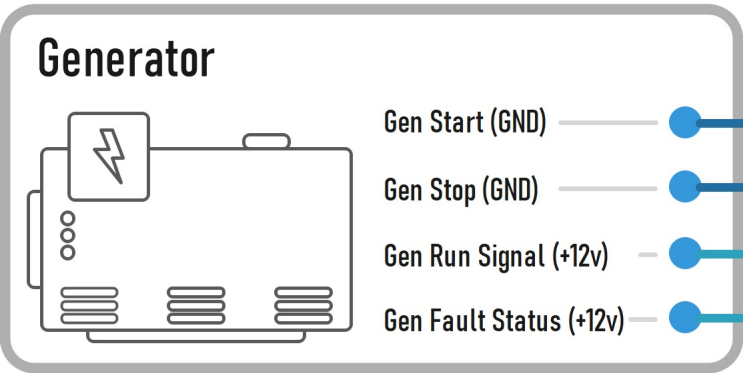
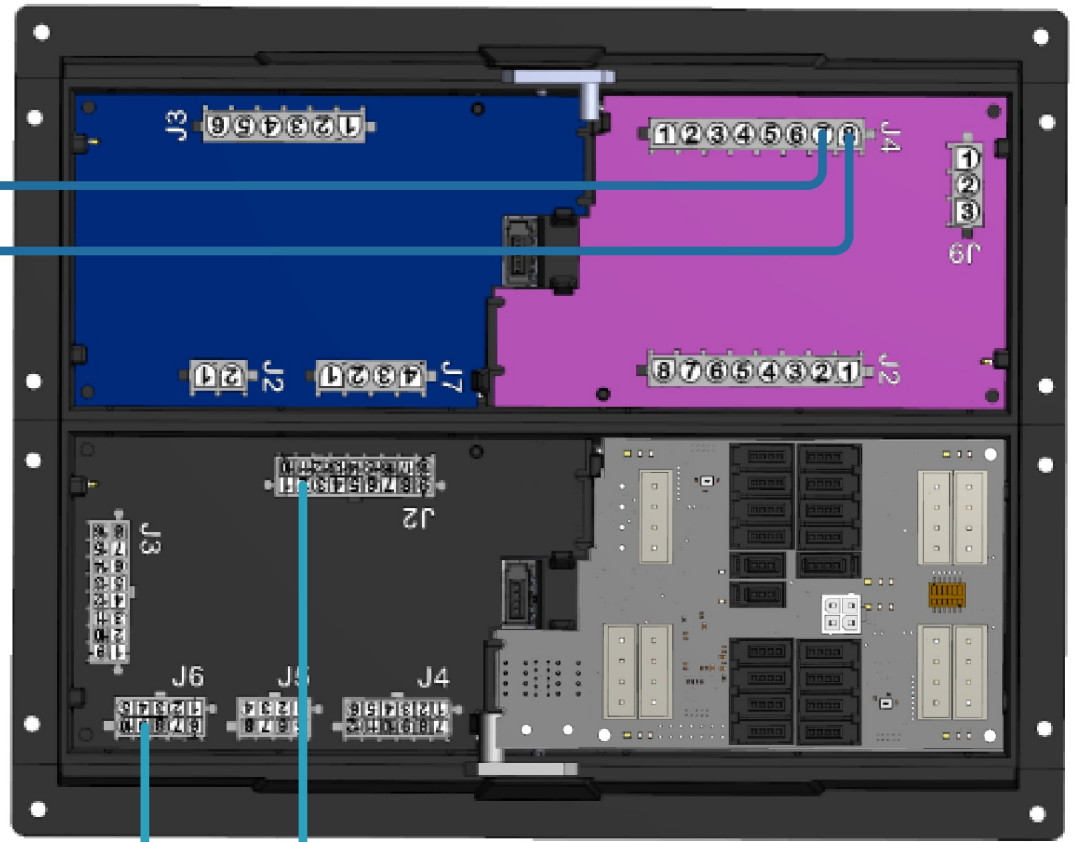

Front M1 Panel

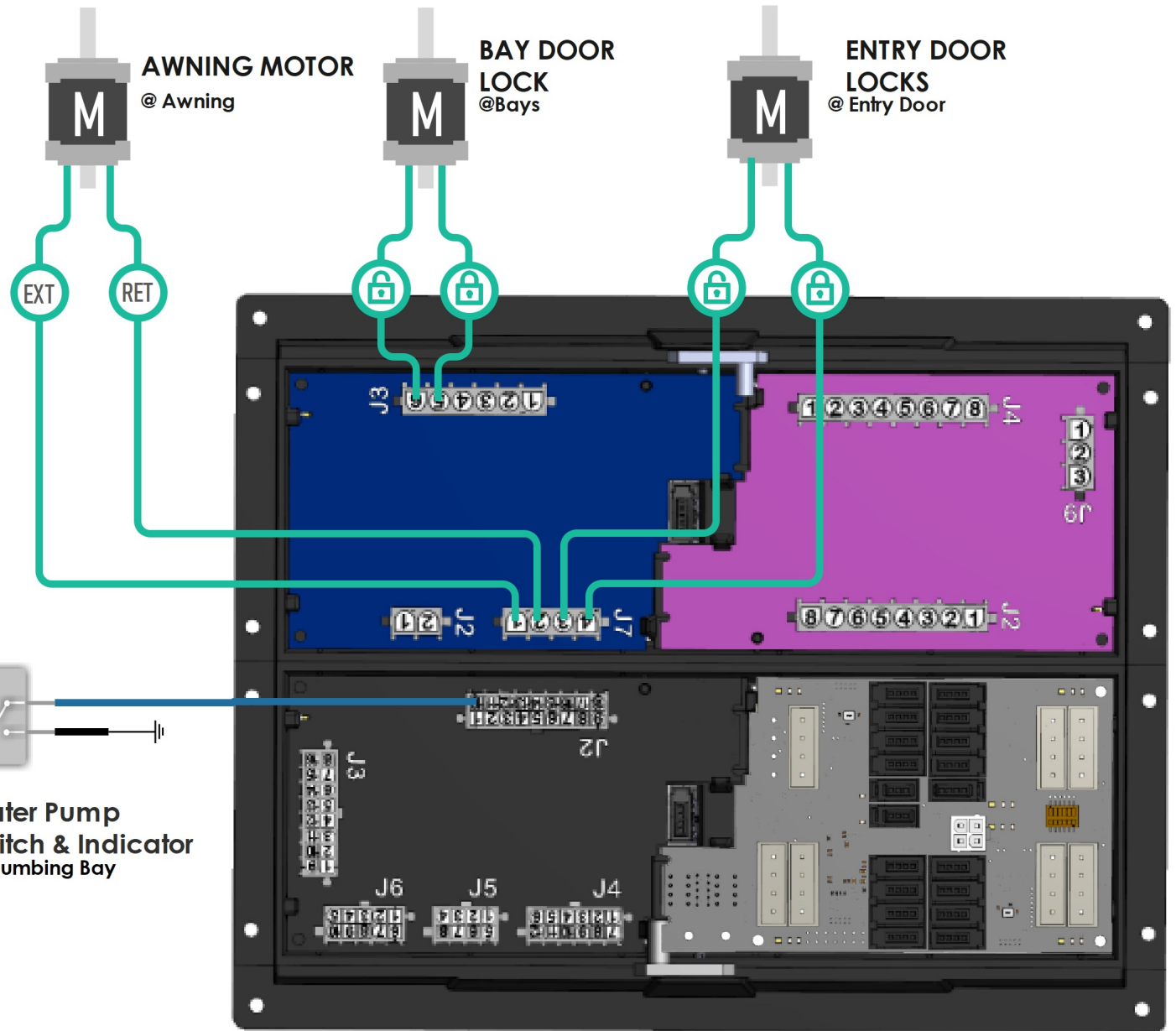
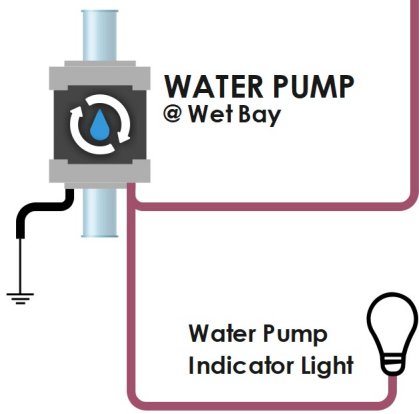
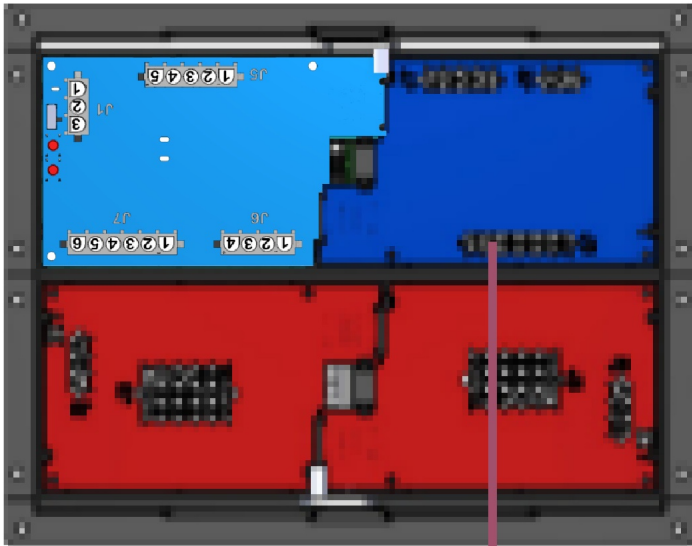

Mid M1 Panel

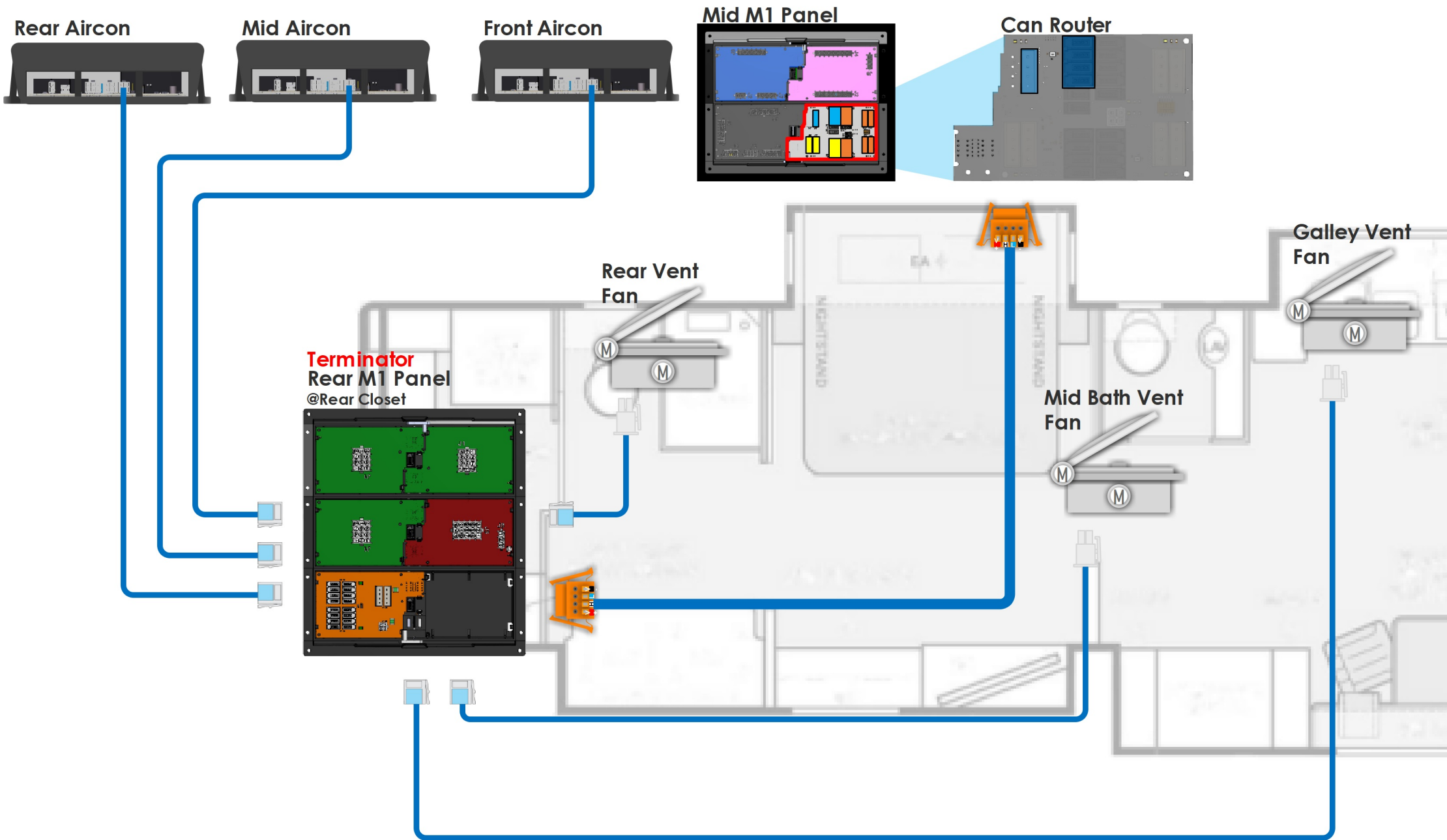

Mid M1 Panel

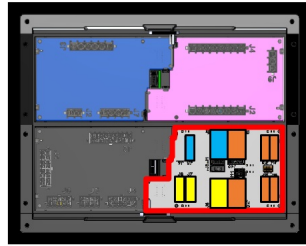

Can Router

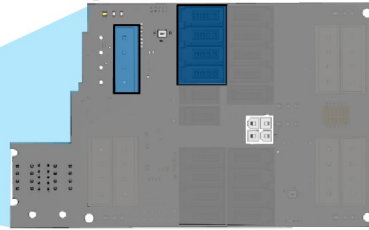

Valid Dash



ACR3
@ Rear Closet

Terminator
Rear M1 Panel
@Rear Closet

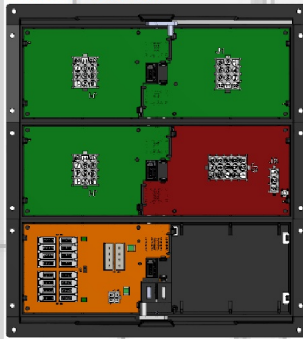

HCR15 TV LIFT
@Rear Closet

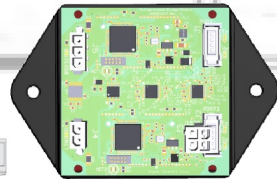

Bridge Module
@Rear Closet



10" Pro LCD
@ Hall Wall



Mira Module
@P/S Overhead Cabinet

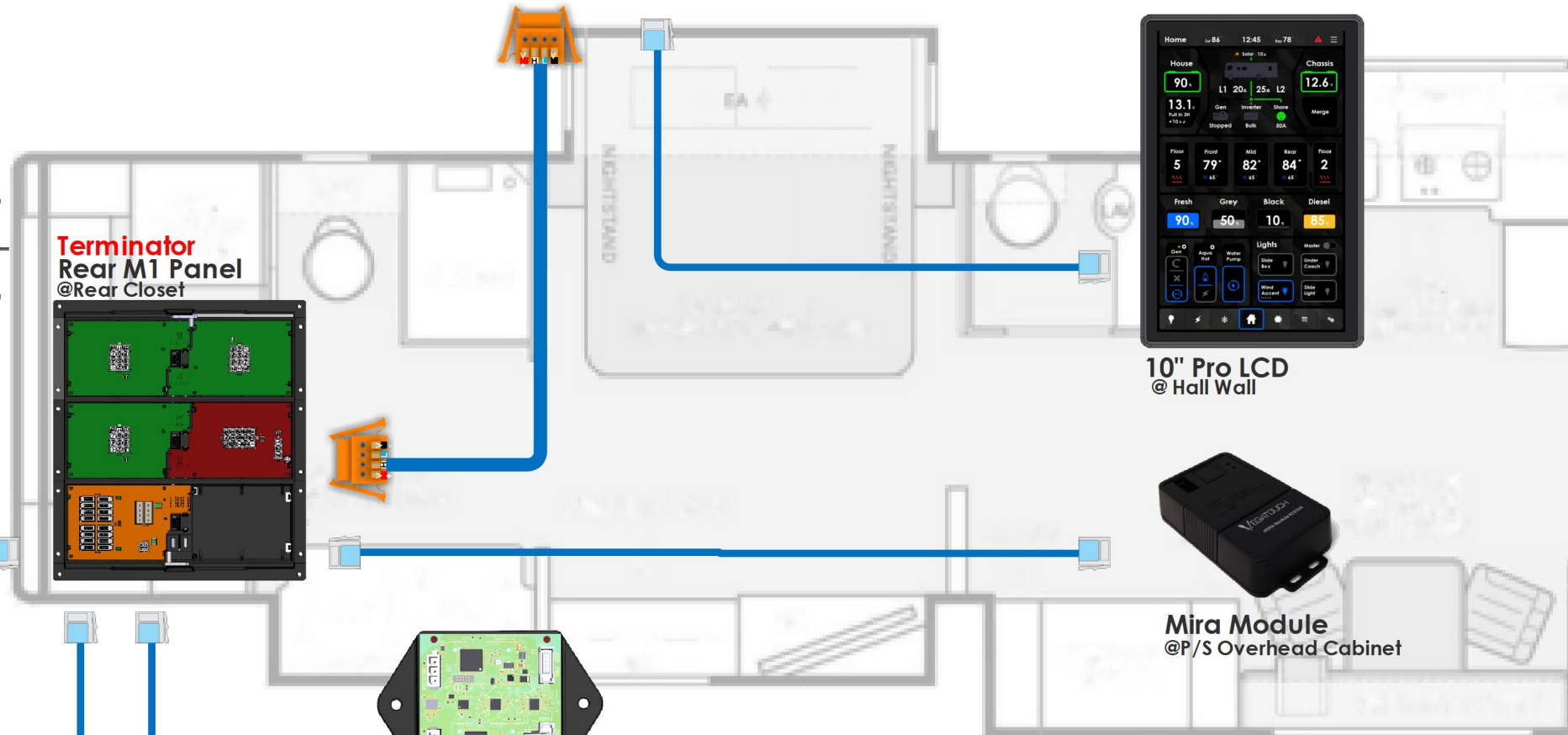

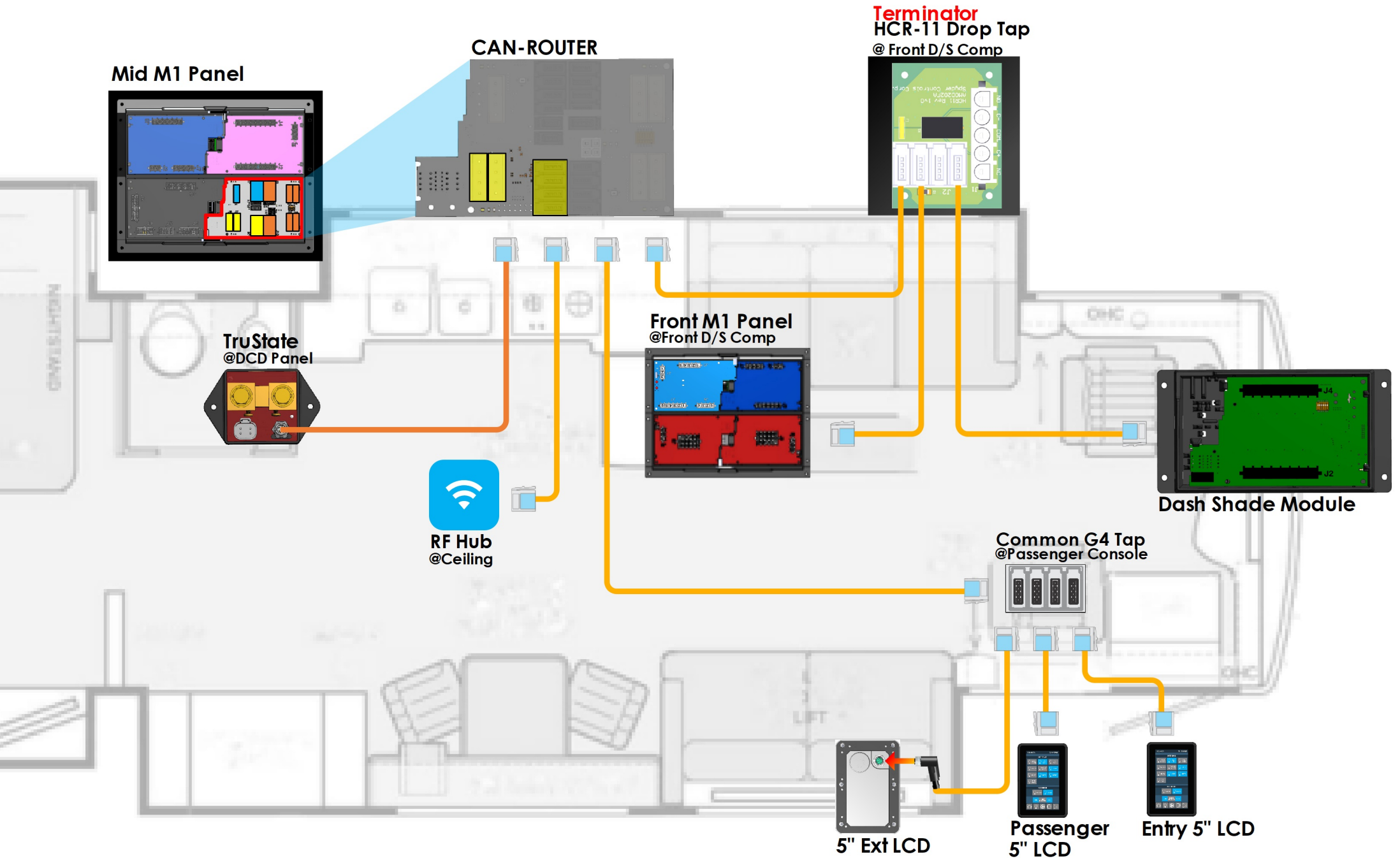

Terminator
HCR-11 Drop Tap
@ Front D/S Comp

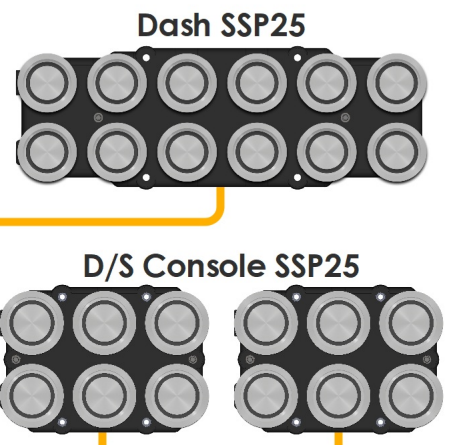
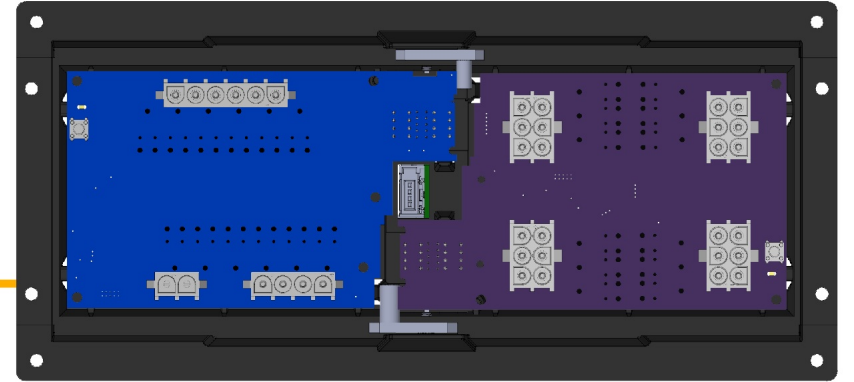
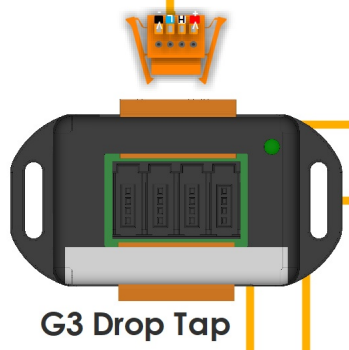
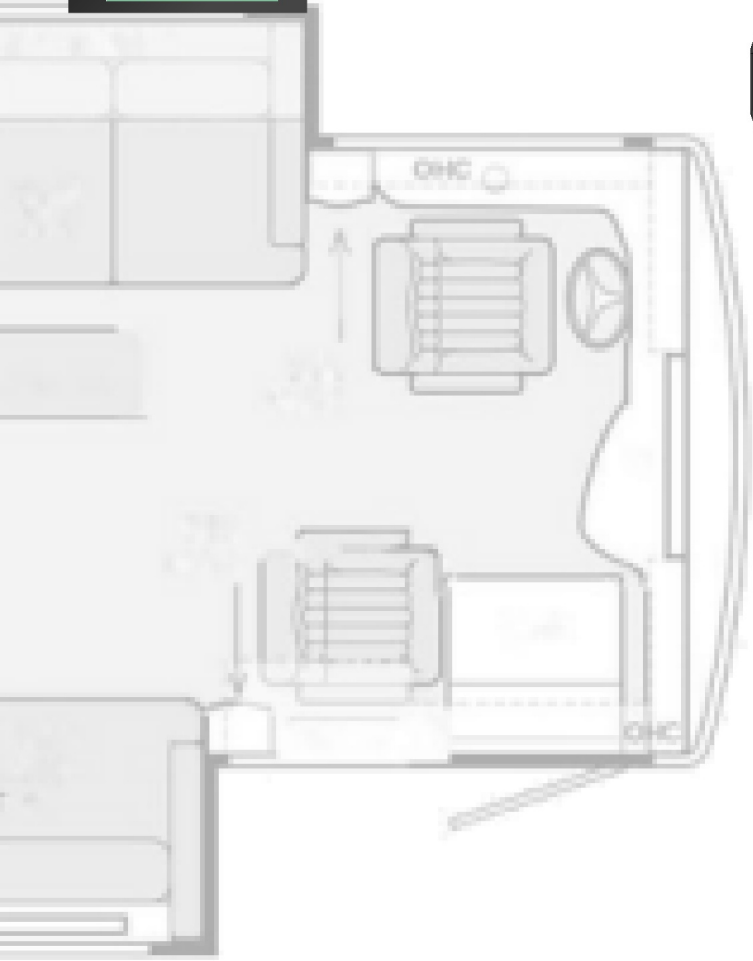
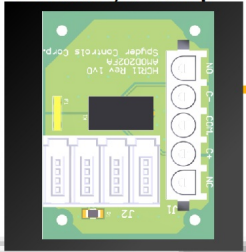

M1 Dash Module

Dash SSP25

D/S Console SSP25

Mid M1 Panel

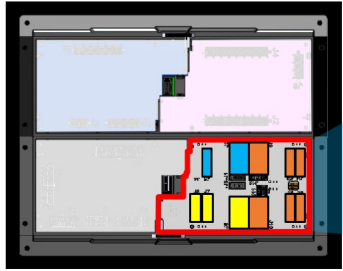

Can Router

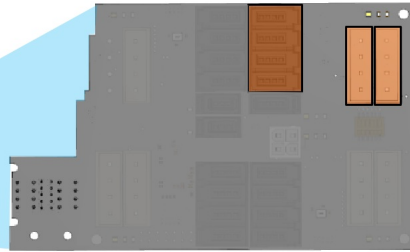

TRC Transfer Switch @ Mid Ext Comp



Go Power! Solar Control



Go Power! Solar Control



Bedroom 5" LCD



G4 Terminator @Under Bed



Bedroom 5" LCD



Common G4 Tap

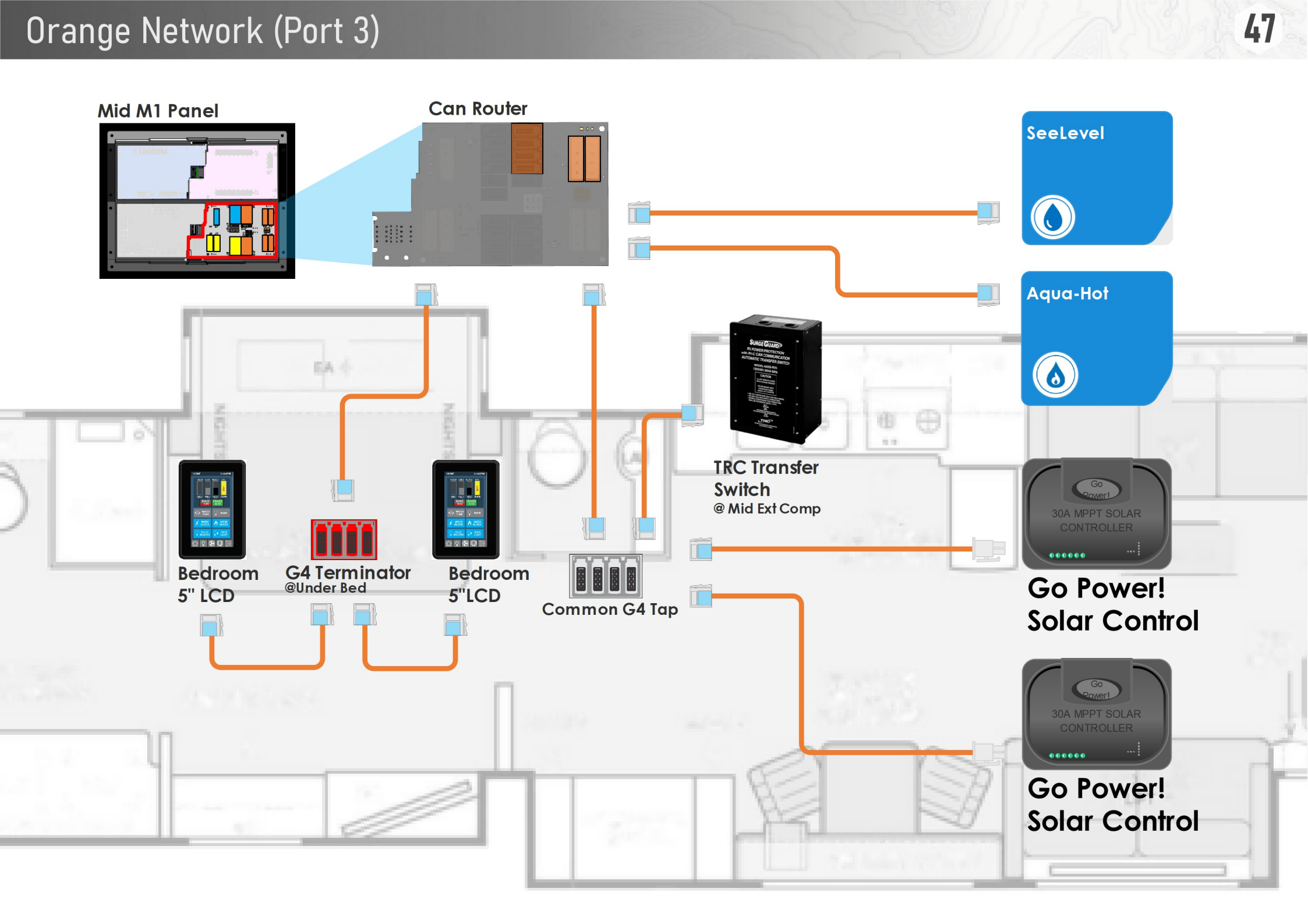

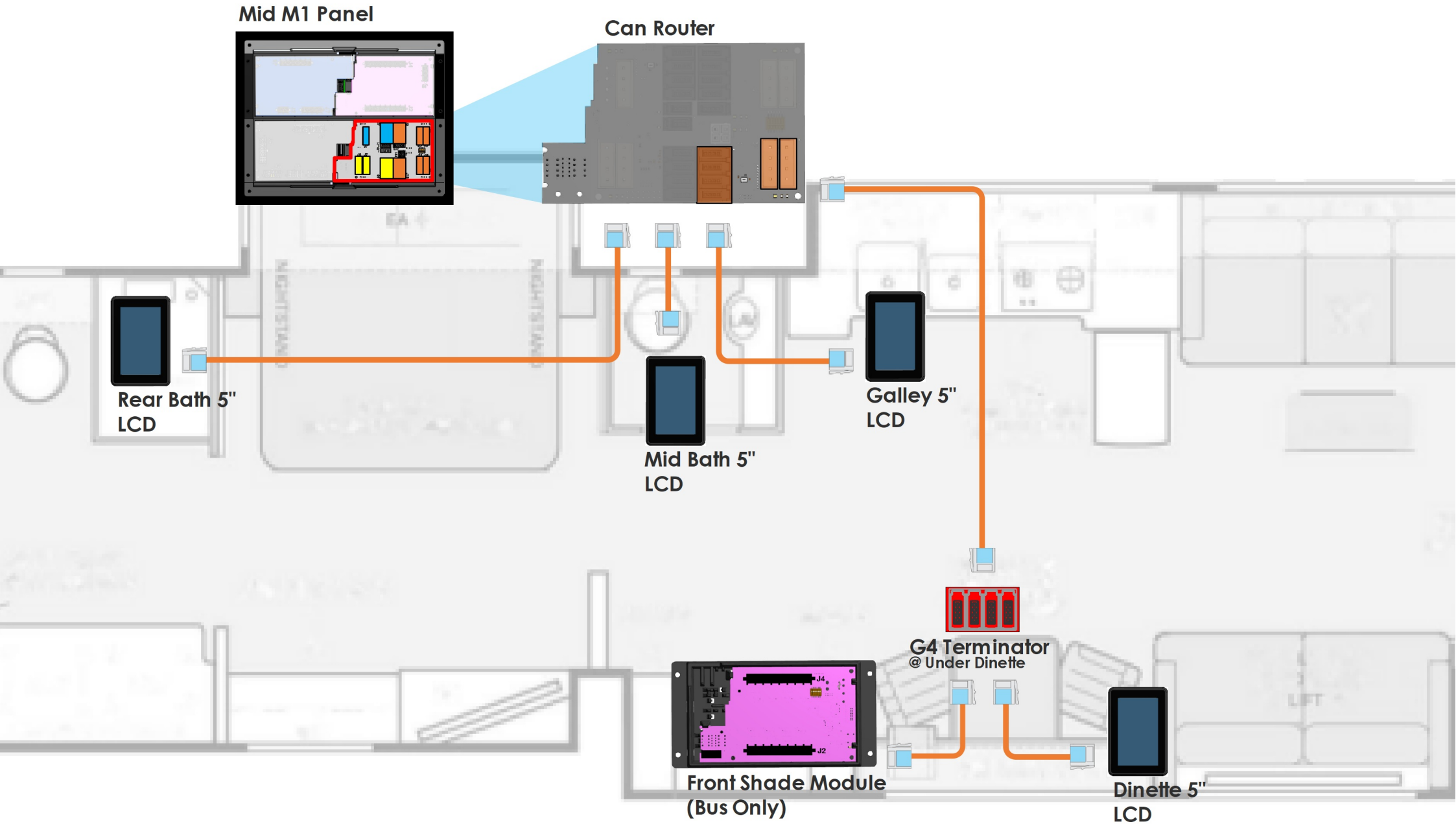

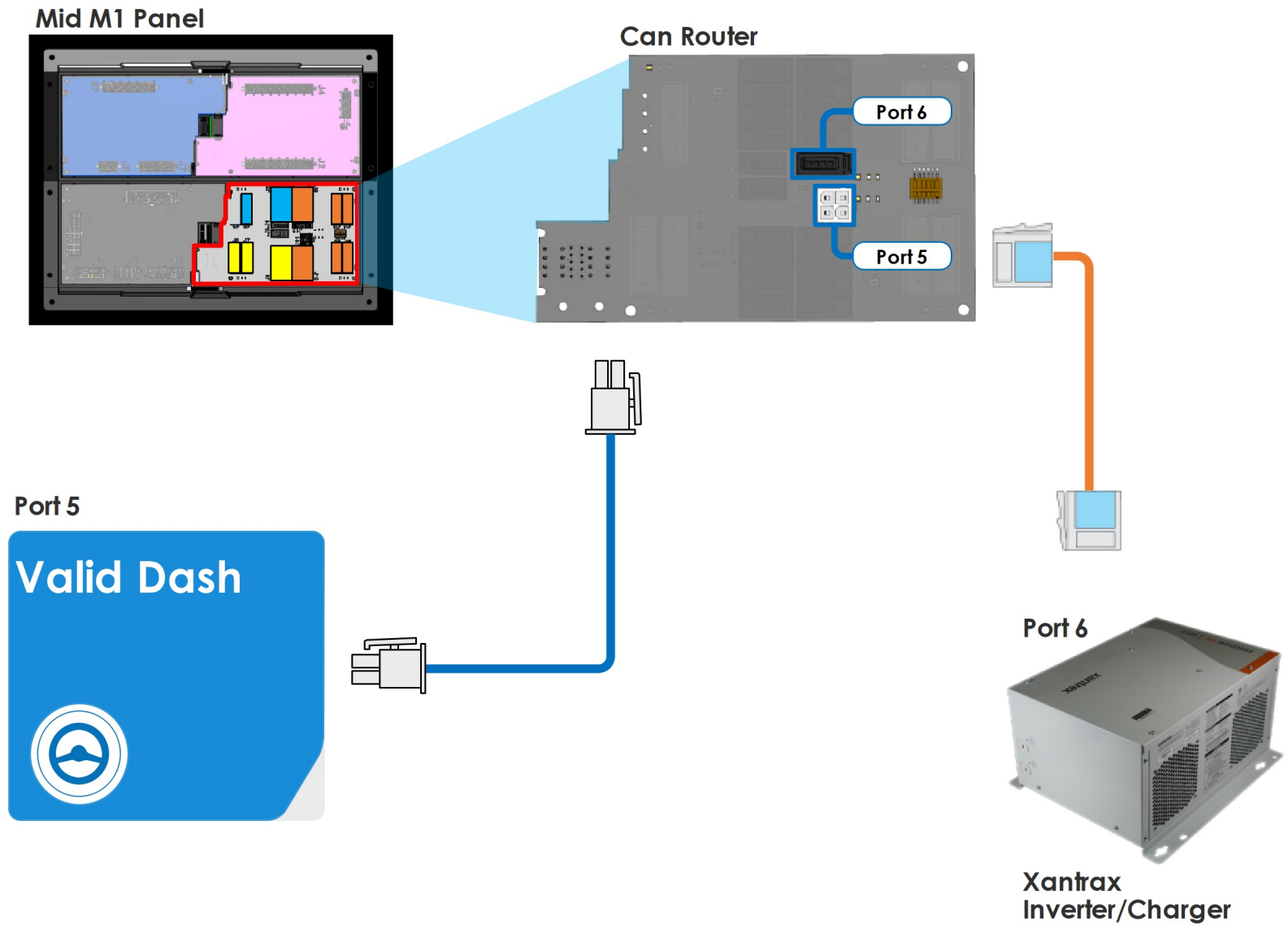

THE ORDER OF THE NETWORK CABLES AT THIS TAP IS IMPORTANT !

The M1 Shade Standalone and the M1 Network Card MUST be plugged into the ports shown. The always on ports are powered when the house disconnect is off.

Tiffin P/N: 5105426
Terminator
HCR-11 Drop Tap
@ Front D/S Comp

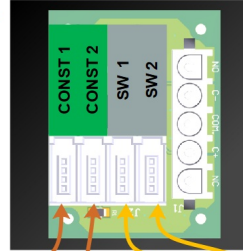

Always On Network
This network to remain powered while house disconnect is off.

Always On Switched

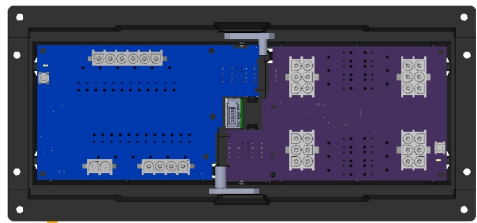

M1 Dash Module

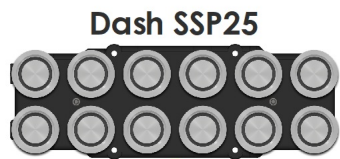

Dash SSP25

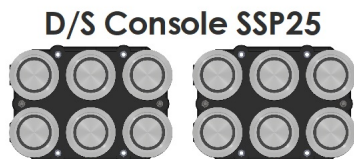

D/S Console SSP25

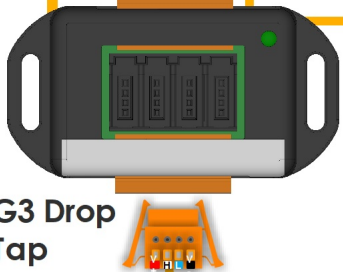

G3 Drop Tap

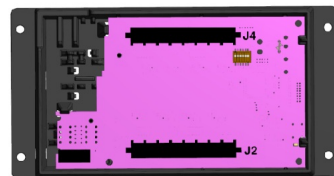

Dash Shade Module
Tiffin P/N: 5127302



RF Hub
Tiffin P/N: 5127293

Front M1 Panel
@Front D/S Comp

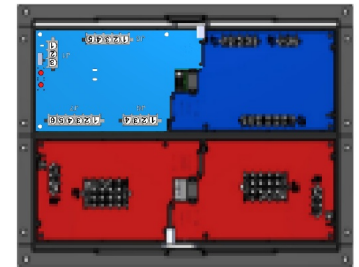

Mid M1 Panel
@ Inverter Bay

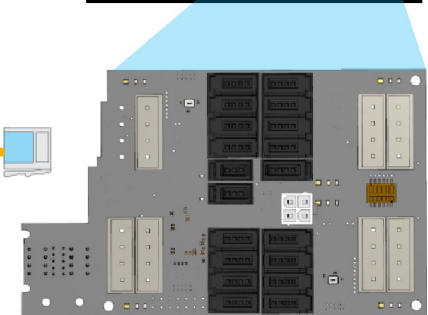

Can Router

BDC 3

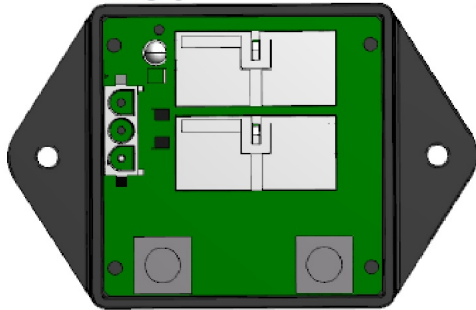

J1		Momentary Switch	
Pin	Description		
3	COIL SET Input	3	
2	COIL RESET Input	2	
1	SWITCH SUPPLY (+12V) Output	1	

*Coil should not be powered for more than 10 sec

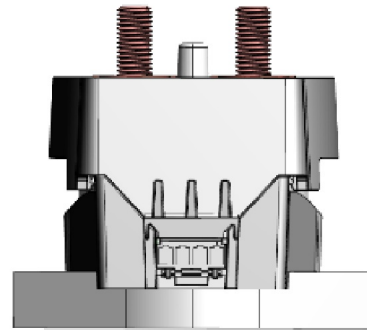

MergeMan

DCD Panel

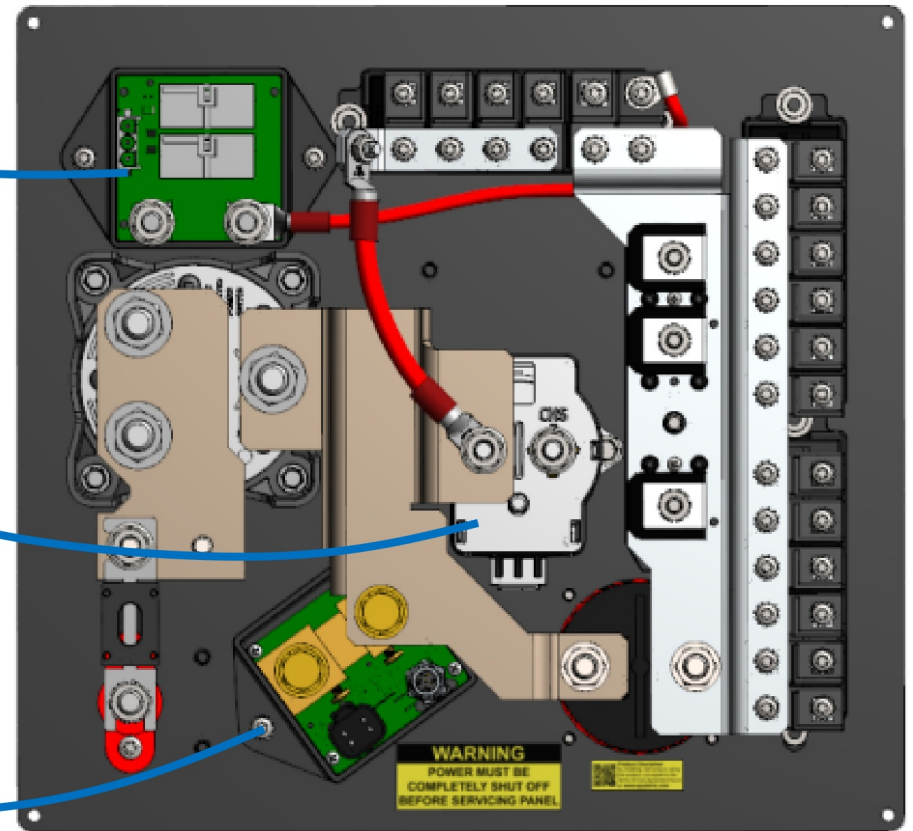

WARNING
POWER MUST BE
COMPLETELY SHUT OFF
BEFORE SERVICING PANEL

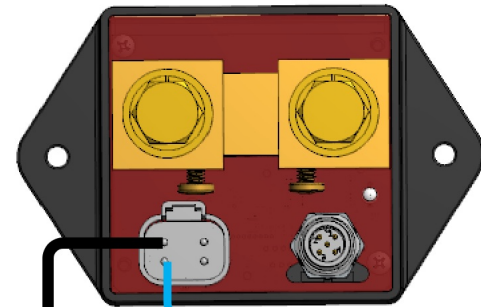

(GND)

Chassis voltage
input (+12v)

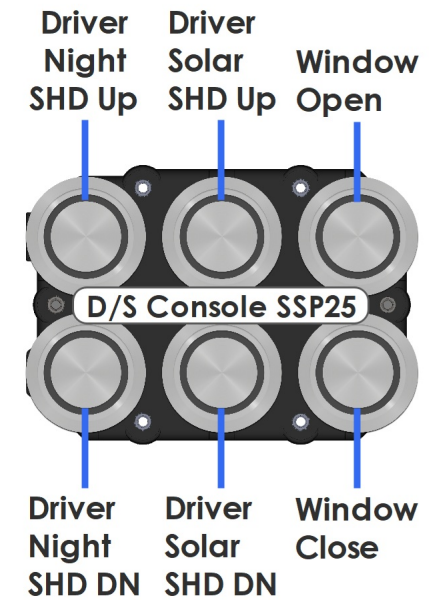
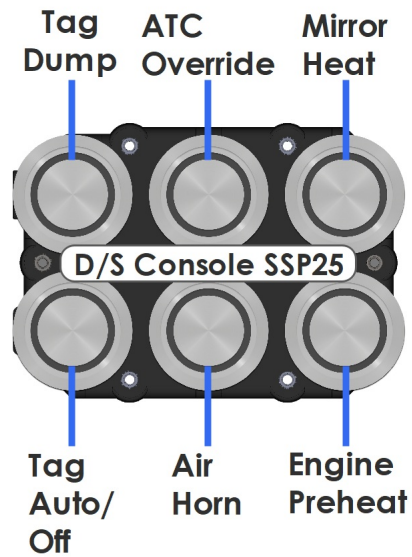
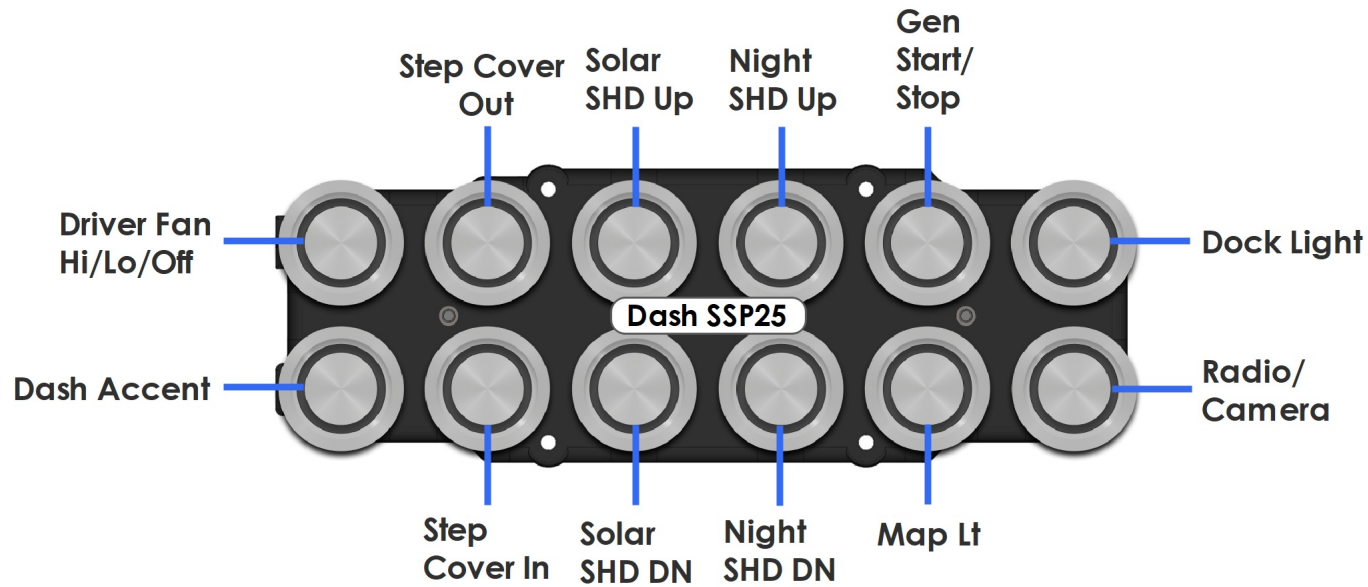

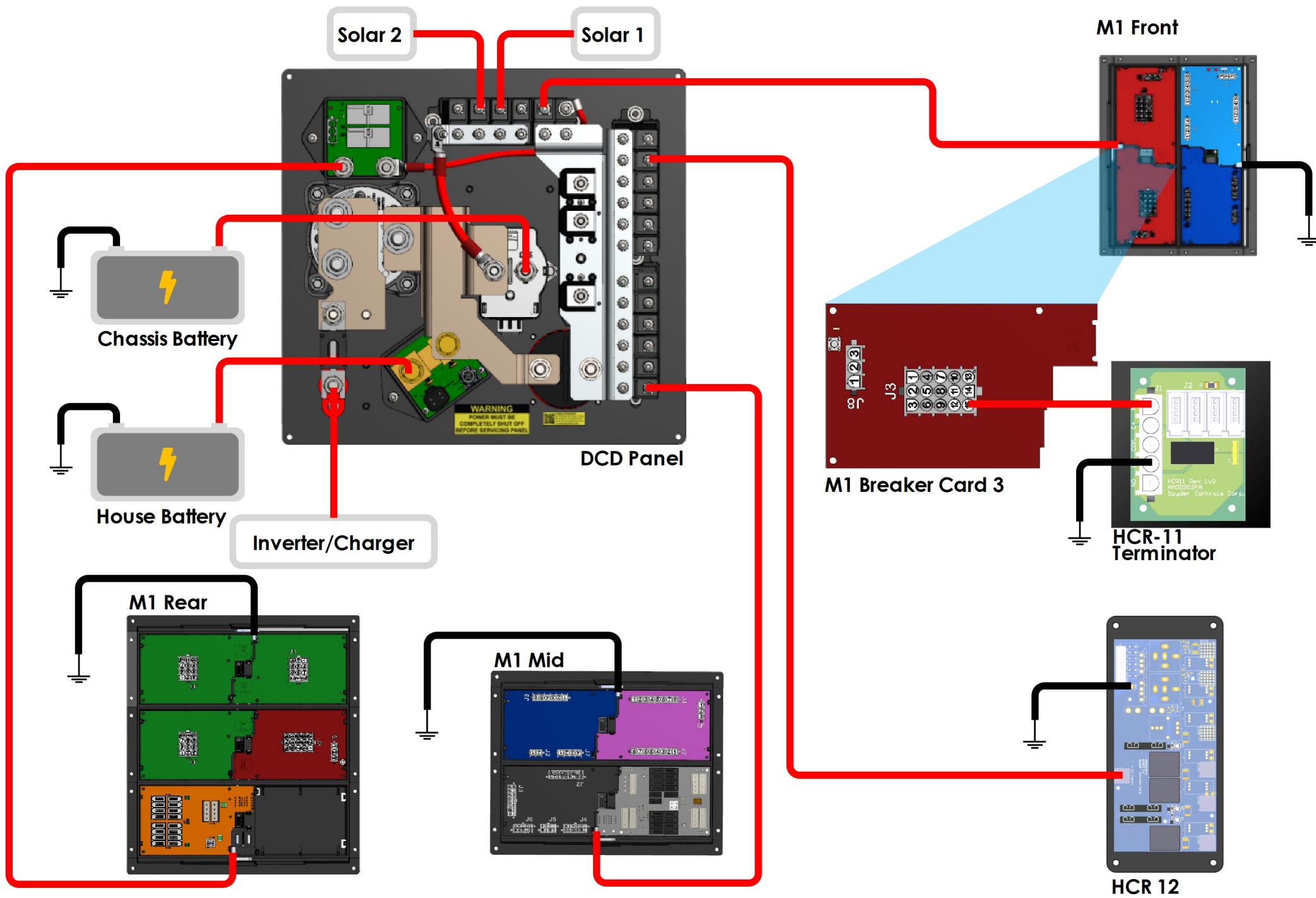

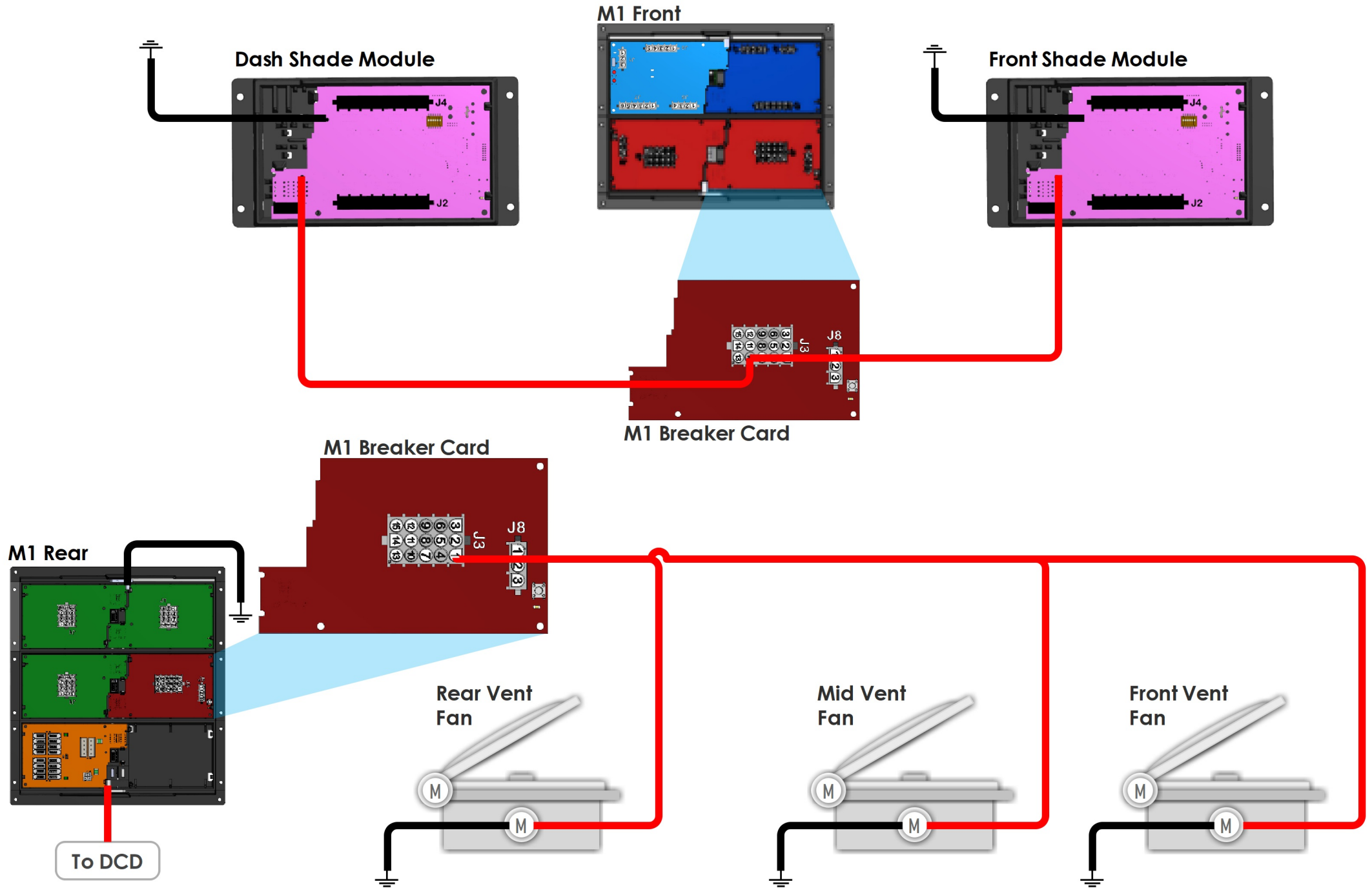

TERMINATOR
HCR-11
 Tiffin P/N: 5105426

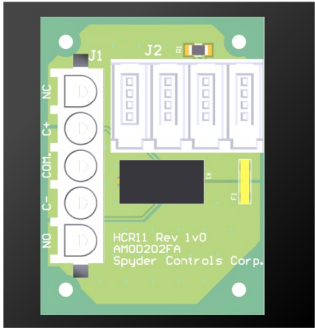

G4 Common Drop Tap
 Tiffin P/N: 5016592

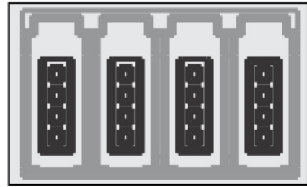

G4 Terminator Drop Tap
 Tiffin P/N: 5051936

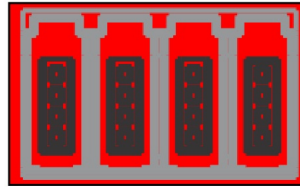

Mini-Clamp Plug
 Tiffin P/N: 5066157
 3M P/N: 37104-2165-000 FL 100



Mini-Clamp Socket
 Tiffin P/N: 5066158
 3M P/N: 37304-2165-000 FL 100



Wago Hook Tool
 Wago P/N: 231-131



4 Pos Wago Connector
 Tiffin P/N: 5015508
 MF P/N: 231-304/037-000



MiniFit Jr Connector
 Digi-Key P/N: 0039012040

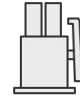

Minifit Jr Pins
 Digi-Key P/N: 0039000181

