

G6A CONTROL PANEL LAYOUT
 Tiffin PN: 5078272 Spyder PN: BENCZ52CE
 2019 RED - HOUSE Rev 3v0
PRELIMINARY PINOUT DIAGRAM - 08.01.2018

Back View

- CONNECTOR 4**
- 4-1 REAR BATH/MID SINK CEILING LIGHTS - (G6 LED 13)
 - 4-2 TASK LIGHTS - (G6 LED 14)
 - 4-3 MID BATH CEILING LIGHTS - (G6 LED 15)
 - 4-4

- CONNECTOR 5**
- 5-1 TV LIFT UP - (G6 LED 17)
 - 5-2 TV ACCENT LIGHTS - (G6 LED 18)
 - 5-3 FURNACE FRONT - (G6 LED 19)
 - 5-4 FURNACE REAR - (G6 LED 20)

- CONNECTOR 6**
- 6-1 TV LIFT DOWN - (G6 LED 21)
 - 6-2 PORCH LIGHT - (G6 LED 22)
 - 6-3 ELECTRIC WTR HT - (G6 LED 23)
 - 6-4 DIESEL / GAS WTR HT - (G6 LED 24)

- J15--- FR TV LIFT COMMON
- J19--- FR TV LIFT COMMON

- CONNECTOR 10**
- 10-1 A/C ON/OFF 1 - (G6 LED 37)
 - 10-2 A/C 1 LO - (G6 LED 38)
 - 10-3 A/C 1 HI - (G6 LED 39)
 - 10-4 A/C 1 STRIP HT - (G6 LED 40)

- CONNECTOR 11**
- 11-1 A/C ON/OFF 2 - (G6 LED 41)
 - 11-2 A/C 2 LO - (G6 LED 42)
 - 11-3 A/C 2 HI - (G6 LED 43)
 - 11-4 A/C 2 STRIP HT - (G6 LED 44)

- CONNECTOR 12**
- 12-1 A/C ON/OFF 3 - (G6 LED 45)
 - 12-2 A/C 3 LO - (G6 LED 46)
 - 12-3 A/C 3 HI - (G6 LED 47)
 - 12-4 A/C 3 STRIP HT - (G6 LED 48)

- CONNECTOR 17 THERMISTER INPUTS**
- GND's
 - MID ZONE THERMISTER INPUT
 - REAR ZONE THERMISTER INPUT
 - FRONT ZONE THERMISTER INPUT

- CONNECTOR 14 (12V+ INPUTS)**
- 14-1 WTR HTR STATUS
 - 14-2
 - 14-3
 - 14-4
 - 14-5

- CONNECTOR 15 (GND INPUTS)**
- 15-1 WATER PUMP SW
 - 15-2 PARK BRAKE INPUT
 - 15-3 CLOSET LIGHT SW
 - 15-4 ENTRY DOOR PIN SW
 - 15-5

- CONNECTOR 18**
- 18-1 FRONT THERMO - **BREAKER #67**
 - 18-2 MID THERMO - **BREAKER #68**
 - 18-3 TOILET/REAR THERMO - **BREAKER #69**
 - 18-4 BRKR TO RR SLIDE - **BREAKER #70**
 - 18-5 FRIDGE - **BREAKER #71**
 - 18-6 - **BREAKER #72**

- CONNECTOR 16**
- 16-1 MACERATOR TOILET - **BREAKER #61**
 - 16-2 FRONT FURNACE - **BREAKER #62**
 - 16-3 REAR FURNACE - **BREAKER #63**
 - 16-4 SWITCHER / LP/IR - **BREAKER #64**
 - 16-5 OUTSIDE TV - **BREAKER #65**
 - 16-6 BRKR TO FR SLD - **BREAKER #66**
 - / SHD MOD

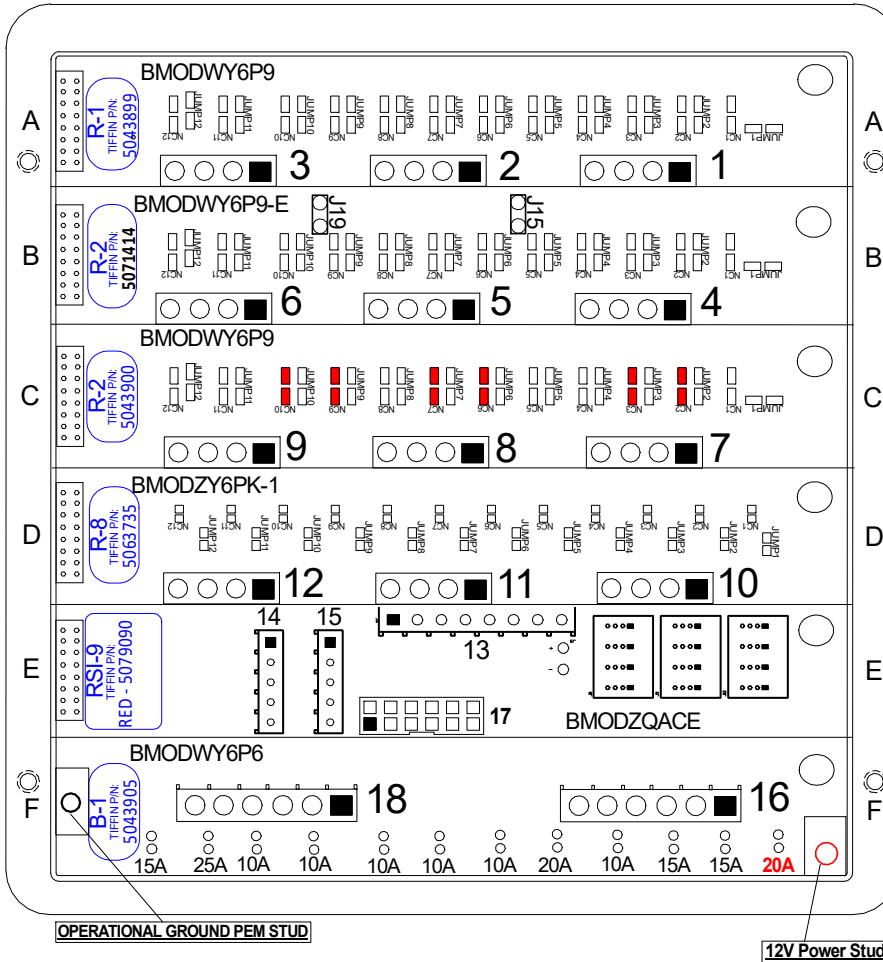

- CONNECTOR 1**
- 1-1 MAIN O/H / LIV RM LIGHT 1 - (G6 LED 1)
 - 1-2 ENTRY / FLOOR LIGHT - (G6 LED 2)
 - 1-3 PS SLIDE LIGHTS - (G6 LED 3)
 - 1-4 DS SLIDE LIGHTS - (G6 LED 4)

- CONNECTOR 2**
- 2-1 MID HALL LIGHTS - (G6 LED 5)
 - 2-2
 - 2-3
 - 2-4 GALLEY LIGHTS - (G6 LED 8)

- CONNECTOR 3**
- 3-1 SCONCE - (G6 LED 9)
 - 3-2 MAIN O/H / LIV RM LIGHT 2 - (G6 LED 10)
 - 3-3
 - 3-4 BEDROOM LIGHTS - (G6 LED 12)

- CONNECTOR 7**
- 7-1 GALLEY FAN ON/OFF - (G6 LED 25)
 - 7-2 GALLEY FAN UP - (G6 LED 26)
 - 7-3 GALLEY FAN DN - (G6 LED 27)
 - 7-4 CLOSET LIGHTS (OPTIONAL) - (G6 LED 28)

- CONNECTOR 8**
- 8-1 MID BATH FAN ON/OFF - (G6 LED 29)
 - 8-2 MID BATH FAN UP - (G6 LED 30)
 - 8-3 MID BATH FAN DN - (G6 LED 31)
 - 8-4 REAR BATH / MID SINK FAN ON/OFF - (G6 LED 32)

- CONNECTOR 9**
- 9-1 REAR BATH / MID SINK FAN UP - (G6 LED 33)
 - 9-2 REAR BATH / MID SINK FAN DN - (G6 LED 34)
 - 9-3 CEILING FAN LO - (G6 LED 35)
 - 9-4 CEILING FAN HI - (G6 LED 36)

- CONNECTOR 13**
- 13-1
 - 13-2
 - 13-3 GND (COMMON FOR SENSORS)
 - 13-4 LPG SENSOR INPUT
 - 13-5 BLACK TANK SENSOR INPUT
 - 13-6 GREY TANK SENSOR INPUT
 - 13-7 FRESH TANK SENSOR INPUT
 - 13-8

Card Legend

- R=RELAY CARD
- B=BREAKER CARD
- RSI-9=INPUT MODULE
- D=DIMMER CARD
- = JUMPED

NOTE: CONNECTORS ARE SHOWN HERE IN THE LOADED (REAR) VIEW.

G6A CONTROL PANEL LAYOUT
 Tiffin PN: 5079061 Spyder PN: BENCZ54CE
RED - CHASSIS Rev 0vA
PINOUT DIAGRAM - 08/01/2018

Back View

- CONNECTOR 4**
- 4-1 WATER PUMP
 - 4-2 HEADLIGHTS (INDICATION FLASH)
 - 4-3 DOOR / ASSIST HANDLE
 - 4-4 CARGO LIGHT

- CONNECTOR 5**
- 5-1 GALLEY SHD UP
 - 5-2 GALLEY SHD DN
 - 5-3 TV SHADE UP
 - 5-4 TV SHADE DOWN

- CONNECTOR 6**
- 6-1 ENTRY SHADE UP
 - 6-2 ENTRY SHD DN
 - 6-3 GEN START
 - 6-4 GEN STOP

- **PARK BRAKE SIGNAL**
- **IGNITION SIGNAL**

- CONNECTOR 13**
- 13-1 MAP LT / RADIO / FANS - **BREAKER #49**
 - 13-2 USB POWER - **BREAKER #50**
 - 13-3 KEYLESS POWER - **BREAKER #51**
 - 13-4 ENTRY STEP SWITCH - **BREAKER #52**
 - 13-5 ENTRY STEP POWER - **BREAKER #53**
 - 13-6 CARGO LIGHTS (CONST) - **BREAKER #54**

- CONNECTOR 15**
- 15-1 POWER SEAT #1 - **BREAKER #55**
 - 15-2 CB - **BREAKER #56**
 - 15-3 ELEC STEP COVER - **BREAKER #57**
 - 15-4 SATELITE - **BREAKER #58**
 - 15-5 SHADES - **BREAKER #59**
 - 15-6 POWER SEAT #2 - **BREAKER #60**

- CONNECTOR 0**
- 0-1 FRONT SLIDE MODULE
 - 0-2 VANITY SLIDE MODULE
 - 0-3 BED SLIDE MODULE

- CONNECTOR 1**
- 1-1 D/S FR SLIDE RET
 - 1-2 D/S FR SLIDE EXT
 - 1-3 P/S FR SLIDE RET
 - 1-4 P/S FR SLIDE EXT

- CONNECTOR 2**
- 2-1 D/S RR SLIDE RET
 - 2-2 D/S RR SLIDE EXT
 - 2-3 P/S RR SLIDE RET
 - 2-4 P/S RR SLIDE EXT

- CONNECTOR 3**
- 3-1 HYDRAULIC PUMP - D/S SLIDE
 - 3-2 HYDRAULIC PUMP - P/S SLIDE
 - 3-3 PORCH/DOOR AWNING CONST
 - 3-4 HYDRA-HOT ENGINE PREHEAT

- CONNECTOR 3A**
- 3A-1 UNDERCOACH CONSTANT

- CONNECTOR 10**
- 10-1 - **BREAKER #37**
 - 10-2 - **BREAKER #38**
 - 10-3 DENSO A/C PWR IGN(YLW) - **BREAKER #39**
 - 10-4 MIRRORS - **BREAKER #40**
 - 10-5 CAMERA IGN - **BREAKER #41**
 - 10-6 JACK BUZZER - **BREAKER #42**

- CONNECTOR 12**
- 12-1 PANEL LAMP/HEADLT LED - **BREAKER #43**
 - 12-2 FRIDGE - **BREAKER #44**
 - 12-3 ENTRY STEP IGN - **BREAKER #45**
 - 12-4 DOCK LIGHT - **BREAKER #46**
 - 12-5 WIPER - **BREAKER #47**
 - 12-6 POWER WINDOW OPTION - **BREAKER #48**

- CONNECTOR 16**
- 16-1 RADIO MEMORY / XM PWR - **BREAKER #61**
 - 16-2 DENSO A/C POWER - **BREAKER #62**
 - 16-3 12V+ OUTLET #1 - **BREAKER #63**
 - 16-4 12V+ OUTLET #2 - **BREAKER #64**
 - 16-5 ENGINE PREHEAT SWITCH - **BREAKER #65**
 - 16-6 HYDRA-HOT (option) - **BREAKER #66**

- CONNECTOR 18**
- 18-1 EMS MODULE - **BREAKER #67**
 - 18-2 CORD REEL - **BREAKER #68**
 - 18-3 HOSE REEL - **BREAKER #69**
 - 18-4 FRONT SLIDE MODULE - **BREAKER #70**
 - 18-5 VANITY SLIDE MODULE - **BREAKER #71**
 - 18-6 BED SLIDE MODULE - **BREAKER #72**

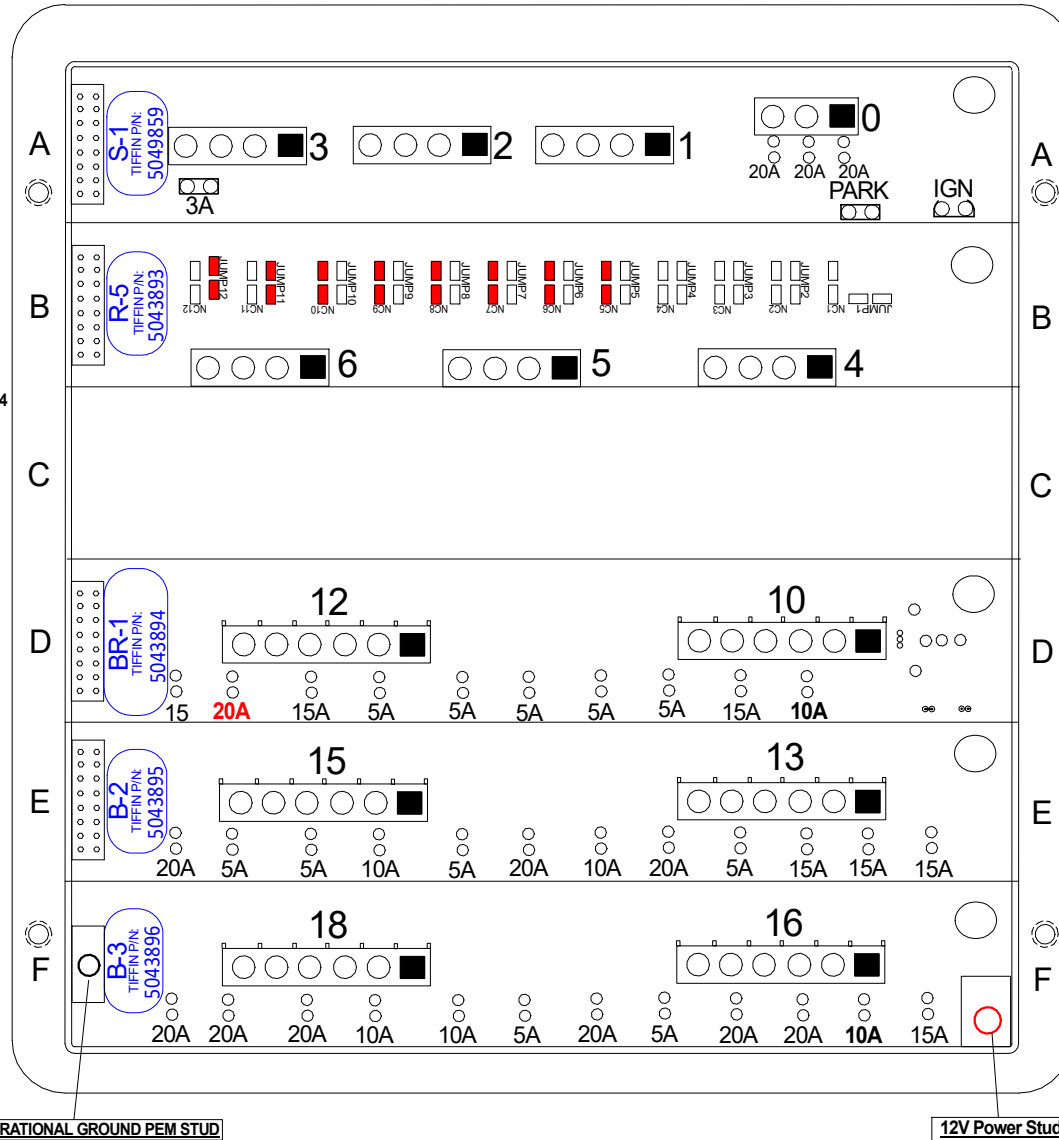

NOTE: CONNECTORS ARE SHOWN HERE IN THE LOADED (REAR) VIEW.

Card Legend

- R=RELAY CARD**
- B=BREAKER CARD**
- BR=BREAKER/RELAY CARD**
- D=DIMMER CARD**
- = JUMPERED**

Tiffin Motorhomes Power Management Module 2019 Tiffin RED, Breeze, Bay Tiffin PN: 5079063 | Spyder PN: BENCZP8CE 03.21.2018

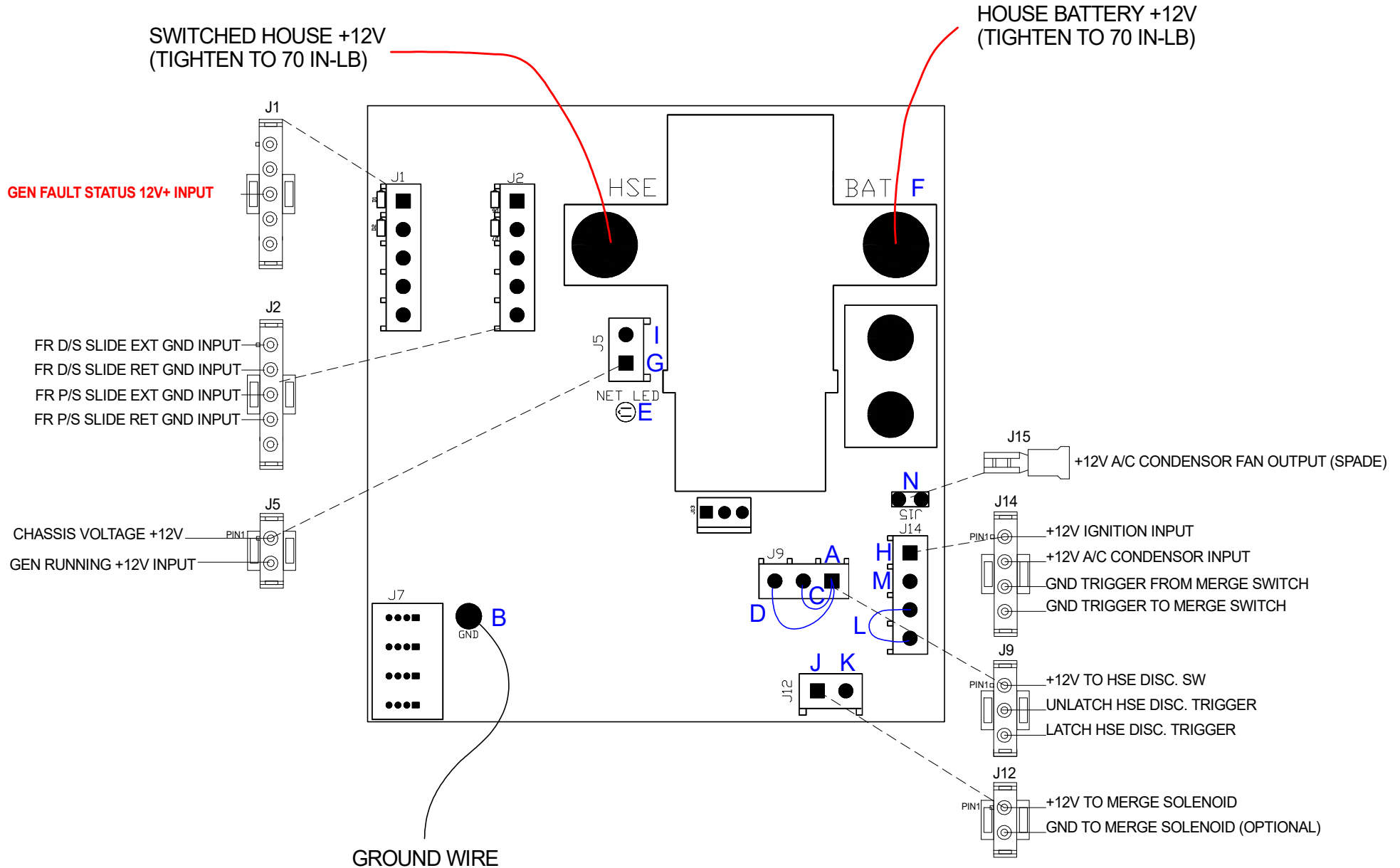

NOTE: CONNECTORS ARE SHOWN HERE IN THE LOADED (REAR) VIEW.