

# 2027 Tiffin Bus, Phaeton, Zephyr 10" LCD USER GUIDE



# Table Of Contents

## Basics 1

- Turning The Screen On
- Interacting With The LCD
- Understanding Status

## Navigation 2

- Bottom Bar
- Diving Deeper
- Using Tabs
- Top Bar Icons

## Page Overview 3

- Page Overview

## Page Overview Cont. 4

- Page Overview

## Home 5

- Climate 3D Model
- Power Diagram

## Lights 7

- Using Light Masters
- Using Dimming Masters
- Light Page Navigation
- Light Button Types

## Lights Cont. 8

- Dimming A Light
- RGB Lights

## Power 9

- Power Flow Diagram

## Power Cont. 10

- Power Flow Diagram
- House Battery Level
- Chassis Battery Level
- Shore Power
- Selecting Shore Power

## Power Cont. 11

- EMS (Energy Management System)
- Inverter Assist
- Inverter Charger

## Power Cont. 12

- AGS (Auto Generator Start)
- Setting Up AGS
- Starting The Generator

## Climate 13

- Climate 3D Model
- Understanding Climate Status

## Climate Cont. 14

- Zone Selection
- Climate Modes
- Climate Navigation

## Climate Cont. 15

- Using The Scheduler
- Aqua-Hot
- A/C Fan Controls
- Thermostat Arcs

## Mech 16

- Slide Safety
- Front Slide Overrides
- Slide Controls

## Mech Cont. 17

- Awning Safety
- Awning Controls

## Mech Cont. 18

- Locks
- TV Lifts
- Bed Lift

## Shades 19

- Shades Navigation
- Shade Masters
- Shade Control

## Settings 20

- Settings Navigation

## Settings Cont. 21

- Settings Navigation



## Turning The Screen On

- The screen is powered by your coach's 12V system and will turn on when house-battery power is available and the disconnects are on.
- The LCD panel will go to sleep after a period of inactivity. If you approach the LCD and it is black (sleeping) tap anywhere on the screen to wake it up.
- If the LCD doesn't turn on and the coach's 12V system is confirmed on, call 866-919-9092.

## Interacting With The LCD

- The screen in your coach uses capacitive touch technology to interpret your touch.
- A firm touch is not necessary for the LCD to interpret your command.
- We recommend using a light and gentle touch when running slides and turning lights on and off.



- Excessive hard pressing and holding may damage the LCD.

## Status

- The Spyder system in your coach is made of many individual modules working together to accomplish what you command it to do. All the Spyder modules in your coach communicate on what we called a network.
- When you press a button on a Spyder screen, that button sends a command across the network. Every Spyder device on the network sees the command, but only the device meant to act on it will respond.
- For example, if the command is to turn on a light, the lighting module receives it and switches the light on. Once it does this, the module sends a message back across the network to let every device know the light is now on.
- The screen that sent the original command also sees this status message and updates the button to show that the light has successfully turned on.

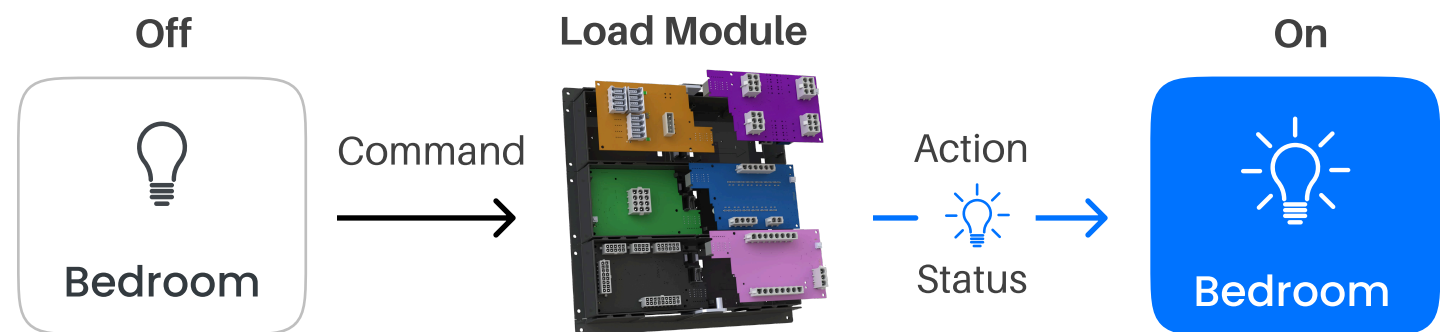

# Navigation

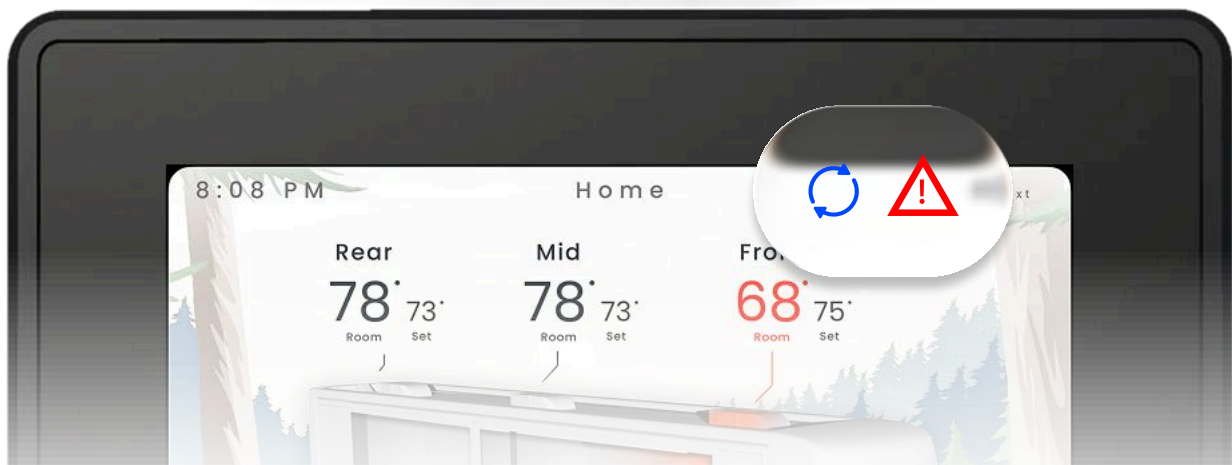
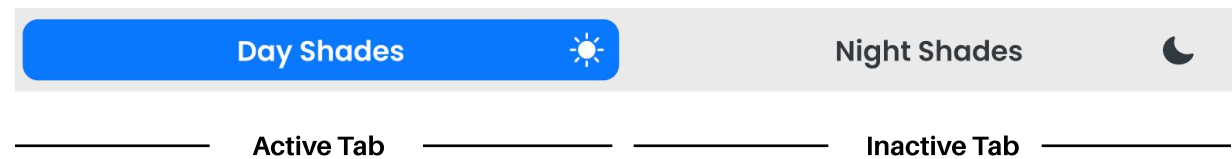
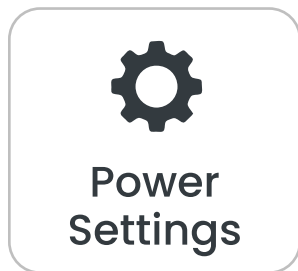
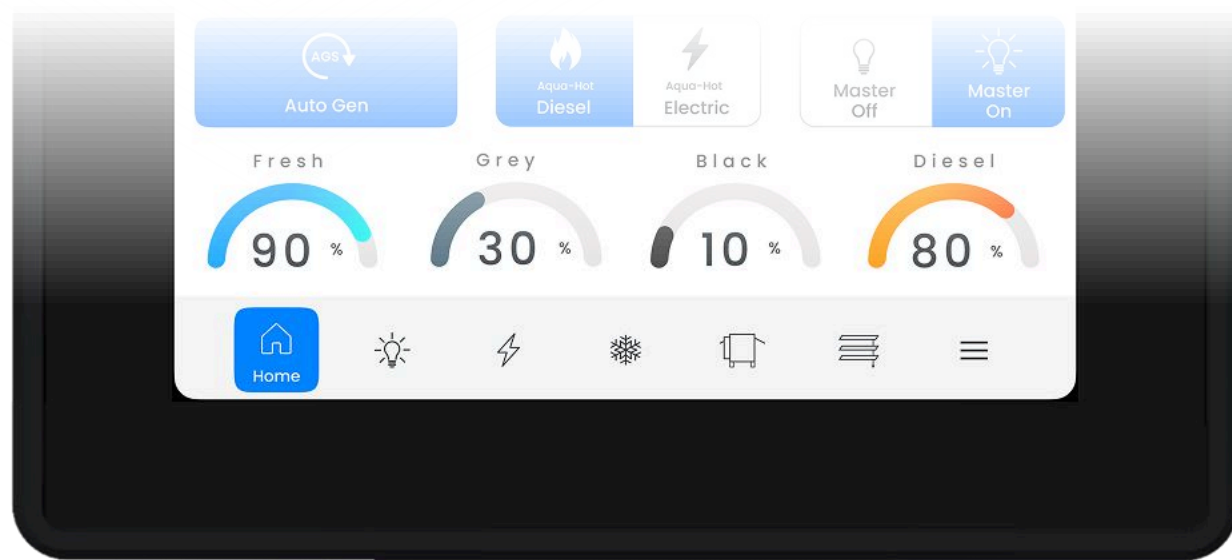

## Navigating With The Bottom Bar

- The bottom bar allows quick navigation between the various systems of the coach. The figure below explains which page the screen will jump to when pressed.
- The navigation item that is highlighted in blue indicates the **active page**, the top left corner of any page will indicate what page you are on, for example it will say "Home" or "Power" in the top left corner.

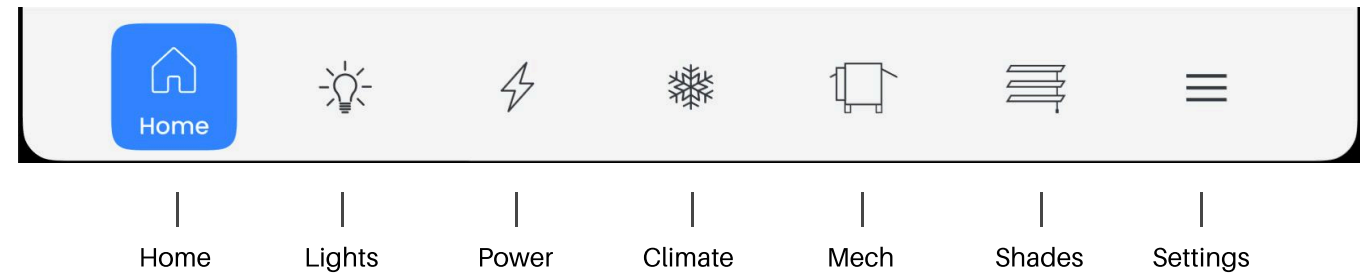

## Diving Deeper

- Some pages have buttons that navigate into deeper settings pages, for example the power page has additional power settings that provides adjustment and insight into the Trustate module, Inverter Charger and Solar System.
- Other buttons like the AGS button opens a pop-up where further setup and information can be accessed.

## Tabs

- Often times relevant information will be grouped together on a single page. This information may not have room to fit on one page or may need to be divided in some way for clarity.
- If you encounter tabs as shown to the left pressing on the unhighlighted area will navigate to it. In the image to the left the active tab is "Day Shades" so day shade controls will be present below the tab. If you tap anywhere on the "Night Shades" text the controls below the tab will change to night shades.

## Top Bar Icons

- Certain icons are displayed in the top bar. These icons generally convey a time sensitive or important event. Tap on them to see additional information.



- Do not ignore a red flashing triangle in the top bar. See "Faults" for more info.

# Pages

## Home Page



- The Home Page displays critical coach information at a glance. It also provides access to commonly controlled loads like generator and light master.
- Your screen will automatically default to this page when it is woken up from sleep. To have the screen default to another page after waking up from sleep navigate to **Settings > Screen Settings > Default Page**.

## Lights Page



- All lights controlled by the Spyder System can be found here.
- The lighting page has tabbing to navigate between different groups of lights. The lights are overlaid on a coach image to aid in understanding.

## Power Page



- The power page shows power flow in the coach on a 3D model of the coach. This power flow illustrates how power moves between power sources and power storage in your unit.
- The following Power systems and controls can be found on this page.
  - EMS (Energy Management System)
  - AGS (Automatic Generator Start)
  - Power Settings (To adjust Trustate, Solar, and Inverter Charger settings)

## Climate Page



- The climate page displays climate information for all three zones on a 3D model. This includes set temp, room temp, and climate status for the various HVAC systems in your coach.
- Navigate here to adjust the temperature, change HVAC modes, set a climate and more.

## Mech Page



- Navigate here to control the following motor loads.
  - Slides extend and retract (Rear Slides, Front Slide - emergency use only)
  - Awnings extend and retract
  - TV lifts, bed lift, door locks

## Shades Page



- Both Day and Night shades can be controlled from this page.
- Use the shade Masters on this page to lift or lower shades in the front, mid and rear of the coach (If equipped with bedroom shades).
- Individually raise or lower shades.

# Pages

## Settings Page

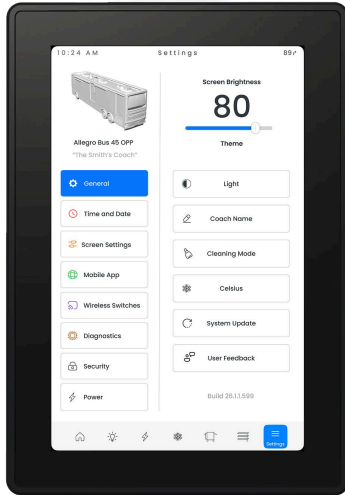

- Navigate to this page to adjust or set the following items:
  - Screen theme
  - Coach Name (Displayed on exterior 5" LCD)
  - Temperature Units
  - Provide feedback
  - Adjust date and time
  - Set screen sleep and default page settings
  - Pair wireless switches
  - Set up the mobile app
  - View diagnostics
  - Adjust security settings and change your entry door pin code
  - View detailed power settings



## Climate 3D Model

- This model displays HVAC status for all climate zones in your coach.
- Each zone has a name, set temperature, and ambient temperature. If a zone is heating the room temperature text will be colored red, if the zone is cooling the room temperature text will be blue.
- The 3D model will update to show status of different HVAC systems. For example, if the front floor heat is heating the coach model will show the front floor as a warm red. To learn more about the HVAC status shown here see the **Climate Page** in this document.

## Power Diagram

- This is a simplified power diagram that gives you an at a glance understanding of power flow in your coach.
- The house and chassis batteries are displayed here with all relevant information. As the battery level changes the level in the battery and color of the batteries will change.
- Generally **Green = Good, Yellow = Caution, Red = Check or Charge Batteries Immediately.**
- The active power source is also shown here. Available sources are Shore, Generator, Inverter.

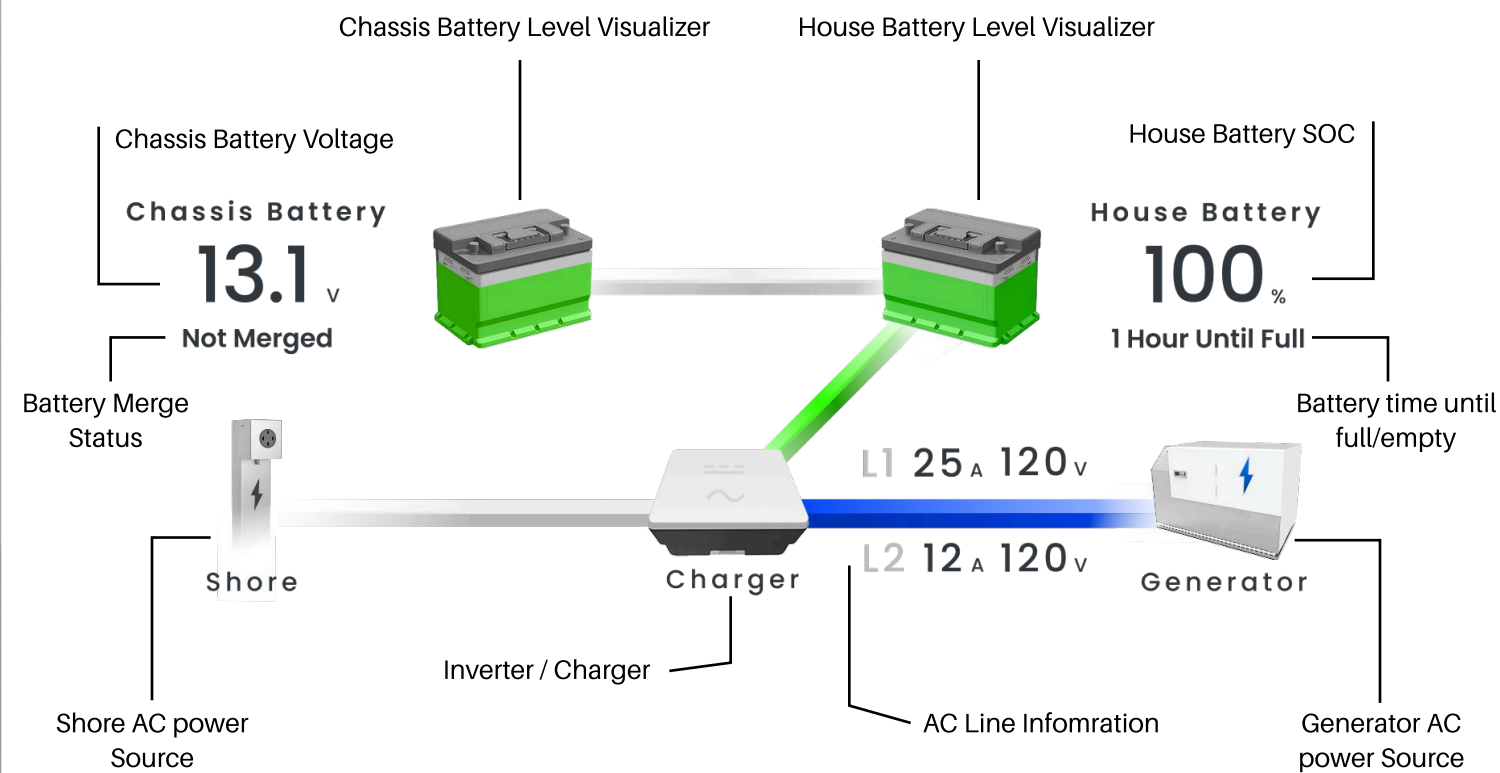

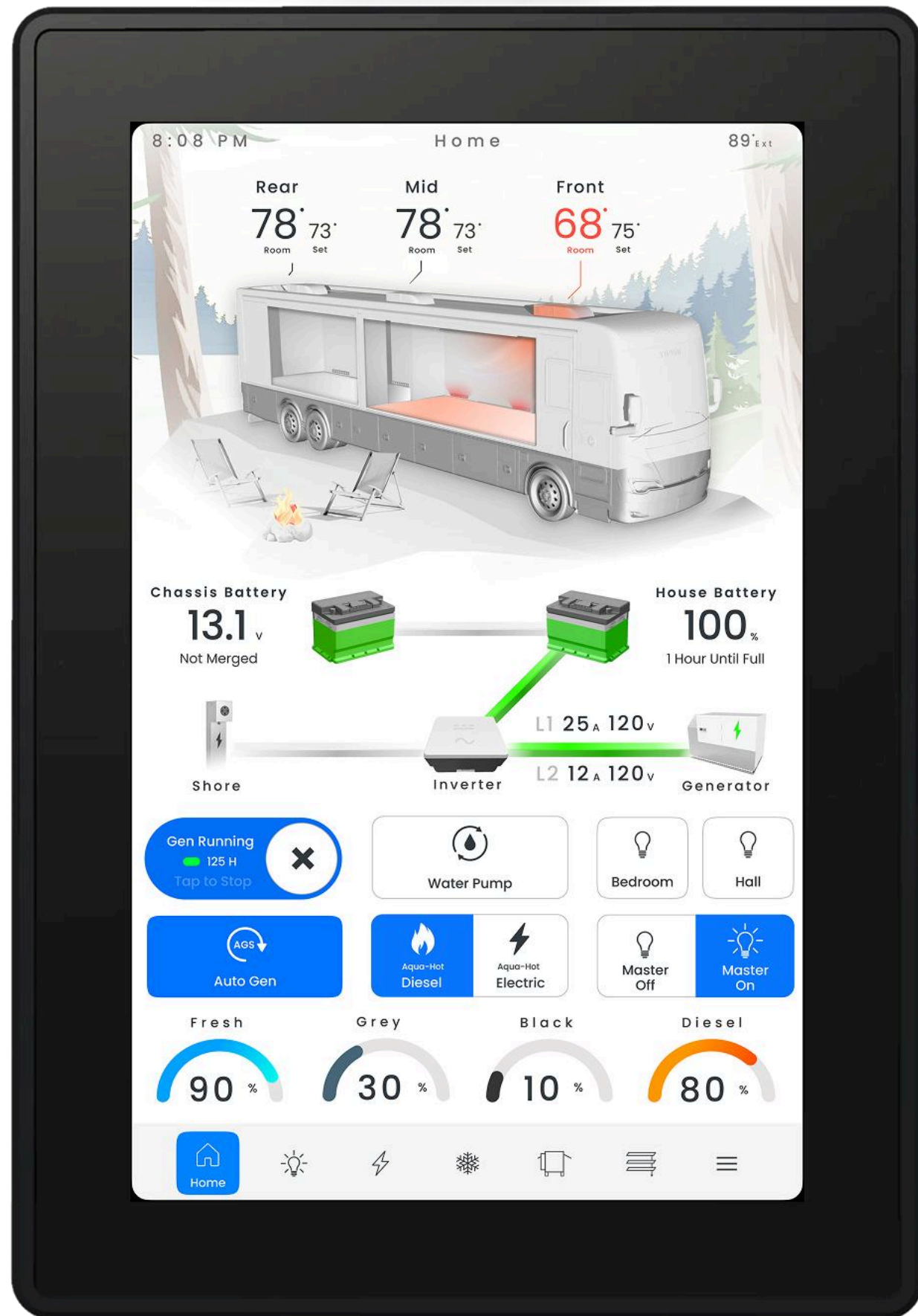

## Common Controls

- This area displays commonly controlled elements such as generator, water pump, water heat and lights. To learn more about the generator button see the **Power Page** in this document.
- **Press and Hold** the light master on button to turn on all lights in the coach. Press the off button to turn them off.
- When turning on the **Diesel Aqua-Hot Heater** the button will flash blue until the diesel burner ignites.
- When turning on the **Electric Aqua-Hot Heater** the button will flash blue, indicating that the load is **Shed**. To learn more about **Shed Loads** see the **Power Page**.

## Tanks

- All tanks are displayed here, these may appear different depending on your coach model.
- Tank levels are displayed from 0-100%. If equipped with LPG the LPG tank graph does not have a percent indication.
- The fresh tank will provide a warning if it is low.
- The Diesel level is provided by the Valid glass dash, this level only updates when the coach ignition is turned on.



## Lighting Masters / Dimming Masters

- The light masters are split into three **Lighting Control Zones**. Main Master (Front living area lights - forwards of bedroom). Bed Master (Rear area lights - bedroom/rear bath). Exterior (Outside lights)

## Using The Light Master

- The **Light Master** allows you to turn on and off all lights in a lighting control zone. In addition to this the light master has a **Memory** function that allows it to remember what lights are on and recall them.
- The **Memory** function works like this: I go into the coach and **Press & Hold Light Master On**. All the light in the coach turn on. I then turn off a few of the lights in the lighting zone to get it just how I like. When I leave the coach I **Press Light Master Off** all the lights shutoff.
- Now to turn on my remembered lights just **Press Light Master On** only my remembered lights will come on. To reset the remembered lights **Press & Hold Light Master On**.

## Using The Dimming Master

- To dim all the lights in a lighting control zone **Press & Hold The Dim Button** below the Master On/Off toggle

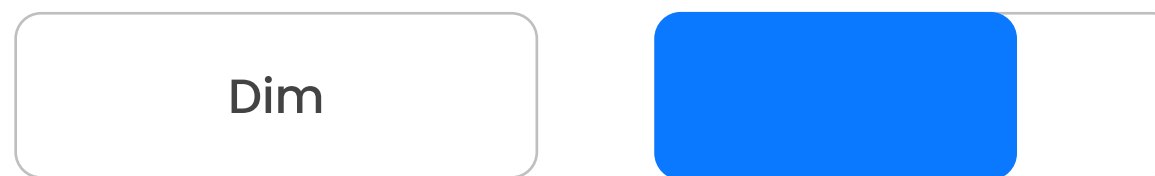

- The dim button will change into a slider. Tap the slider to start dragging it, as you drag it you will see the brightness of lights in the zone adjust to the position of the slider. All the way left is off all the way right is full brightness. When you release the light value is saved and the slider will disappear.

## Light Page Tabbing

- These tabs allow you to navigate between the various **Lighting Control Zones** in the coach. This section will look different depending on coach model.

## Light Buttons Types

- All lights in the selected **Lighting Control Zone** are displayed here.
- To turn a light on tap it, to turn it off tap it again.





## Dimming A Light

- Dimming lights will have an arc or halo above the light, this indicates it is a dimming light. When the light is dimmed the halo will illuminate the dimmed level of the light.

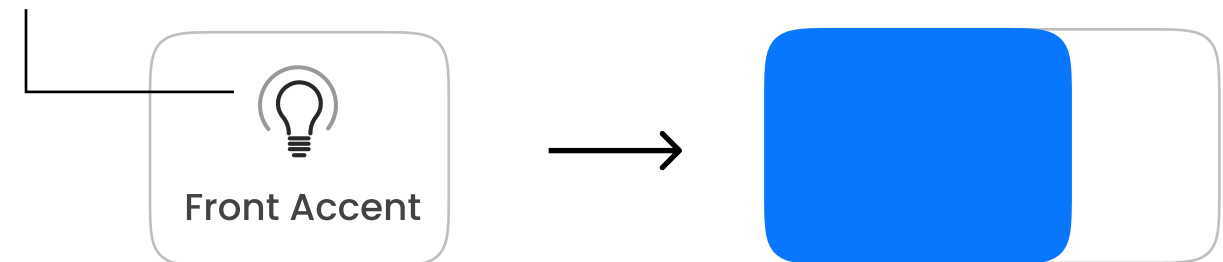

- **Press & Hold a Dimming Light** the dimming light button will change into a slider.
- Tap the slider to start dragging it, as you drag it you will see the brightness of the light adjust to the position of the slider. All the way left is off all the way right is full brightness. When you release the light value is saved and the slider will disappear.

## RGB Dimming / RGB Color Change

- RGB lights are shown with a bar containing the colors red, green, and blue, indicating that the light supports RGB control. When the light is dimmed, the halo around it displays the current brightness level and is filled with the color the light is set to.

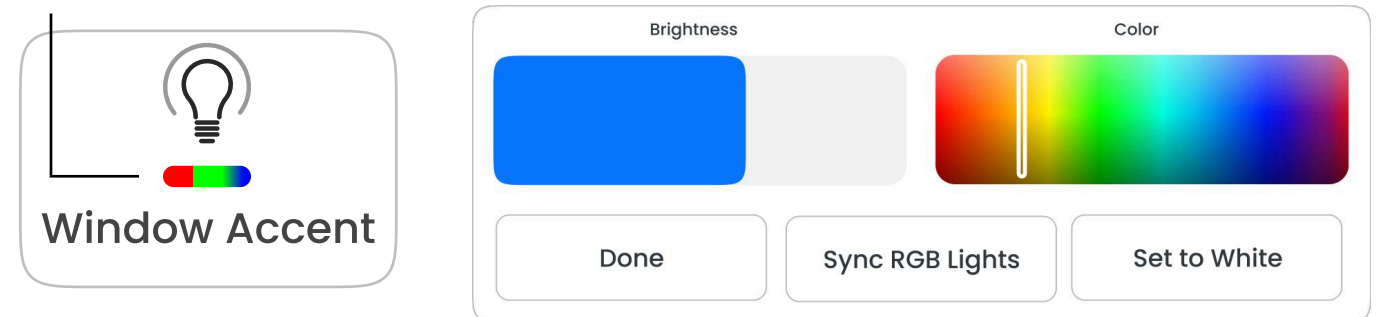

- **Press & Hold a RGB Light.** The RGB light button will bring up a pop-up. This pop-up contains two sliders. The first slider on the left controls the RGB lights brightness. Slide it from left to right to set it at a desired brightness. The second slider adjusts the RGB color, slide the toggle to the desired light color.
- If you would like all RGB lights in the coach to be one color, select the a RGB light. Adjust the brightness and color of the light. Press **Sync RGB Lights** this will set all RGB lights to the color of the current RGB light.
- To set the current RGB light color to white press **Set to White**.
- Press **Done** or tap anywhere outside of the pop-up to save your settings and exit.



## Power Flow Diagram

The power flow diagram allows an at a glance overview of the power flow in your coach. The diagram contains colored tubes that illustrate the power flow between power sources and other modules.

- Green Tubes indicate DC power flow
- Blue Tubes indicate AC power flow
- Grey Tubes indicate no power flow/standby

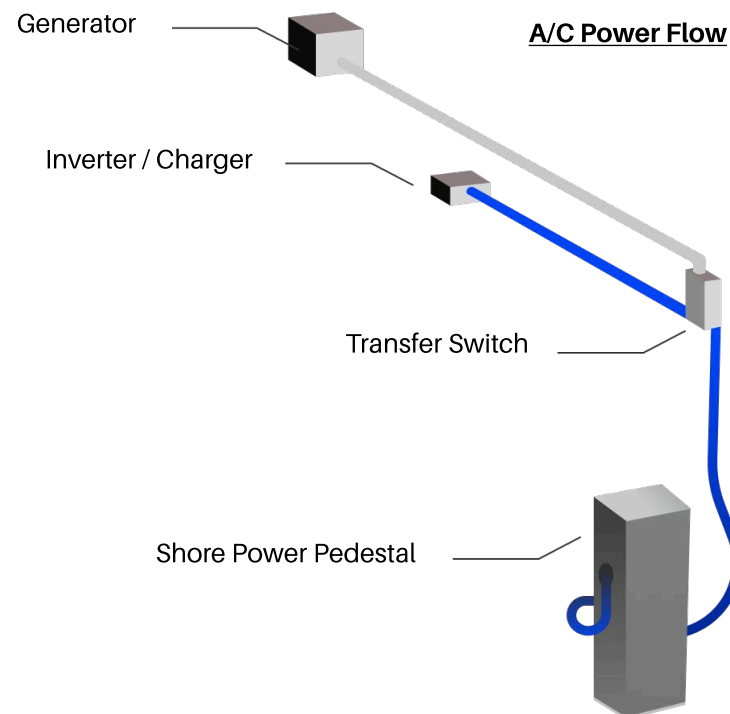

- This diagram is not an exact representation of your A/C or D/C system. It is a general overview to aid in your understanding of the coach power system.
- In the A/C system A/C power can be provided from three places.
  - Generator
  - Shore
  - Inverter (Changing D/C battery power to A/C)
- Generator and shore power run to the transfer switch before being passed to the inverter / charger.

## D/C Power Flow

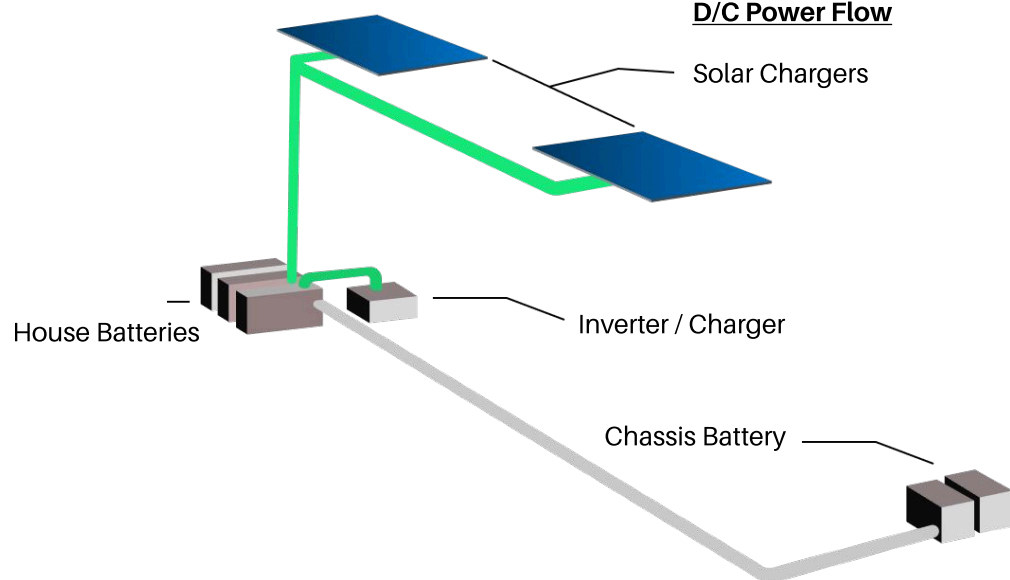

- The solar panels are optional. If solar panels are not equipped in your unit you shouldn't see any information for solar.
- Solar panels on the roof are connected to solar controllers in the coach. DC power from these controllers is provided to the batteries through the Spyder DCD panel.
- The house batteries store D/C power. This power is used by the 12V system in your motorhome to function.
- The house batteries charge primarily from the inverter / charger. The inverter portion of the inverter charger (IC) takes A/C power converts it to D/C power and passes it to the charger which charges the batteries.

- The chassis batteries are mainly for starting the engine, but they also power several Spyder Controls modules.
- Maintaining proper charge levels for both the house and chassis batteries is important. The Spyder system **automatically** connects (or "Merges") the two battery banks when needed to keep them at a healthy charge level. When this happens, a green line appears between the house and chassis battery icons to indicate the connection.
- Press the **Power Settings** button to view more info and setup battery bank, Trustate SOC, and Solar Controllers

# Power

## House Battery Level

+ 20<sub>A</sub>

— This box indicates the D/C current that is entering or leaving the house batteries.  
 — A positive number means the house batteries are charging. A negative number means the house batteries are discharging.

90%  
2 Hours Till Full

— This box indicates the house battery **SOC (State of Charge)**, which shows the current battery level—similar to the battery gauge on an electric car or cell phone. Below the SOC is a **time till full / time till empty** timer, this provides you with an estimation of total time to charge the battery or total battery time until empty.

13.1<sub>V</sub>

— This box displays the house battery voltage.



House

— This is a visual representation of the battery level see Fig.1 for more info.

- The house batteries store D/C power. This power is used by the 12V system in your motorhome to function. The Spyder System also runs on this power. Understanding and maintaining a good charge level in your house batteries is very important

## Chassis Battery Level

12.9<sub>V</sub>

— This box displays the chassis battery voltage.

Not Merged

— This displays the **Merge** status. See previous page for merge description.



Chassis

— This is a visual representation of the battery level see Fig.1 for more info.

	Green indicates a good battery charge level			Yellow indicates a acceptable battery level	
	SOC:	100% - 64%		SOC:	64% - 49%
	Voltage:	13.0V - 12.4V		Voltage:	12.4V - 12.0V
	Red indicates a low battery level charge now!			Indicates that the Trustate Module that provides SOC readings for the house batteries is offline. Contact Spyder at 1-866-919-9092.	
	SOC:	49% - 0%			If this box says <b>Calculating</b> , let the house batteries charge to 100%. If this persists contact Spyder at 1-866-919-9092.
	Voltage:	12.0V - 0V			

Fig.1 - SOC: State of Charge

## Shore Power

This illustration displays the coach connection to shore power.

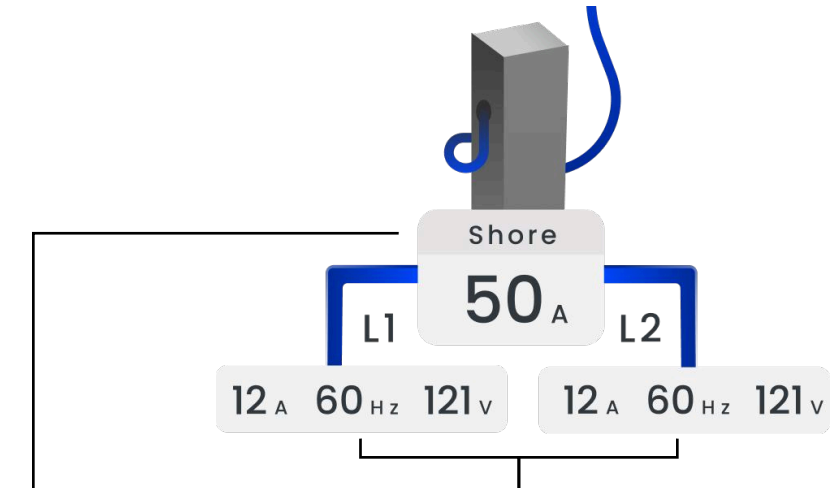

- This box shows the breaker size of the shore source you are connected to, learn more about selecting breaker size below.
- The line current draw, line frequency and line voltage are displayed per line in these boxes. Single phase power will only show information for one line.

## Selecting Shore Power

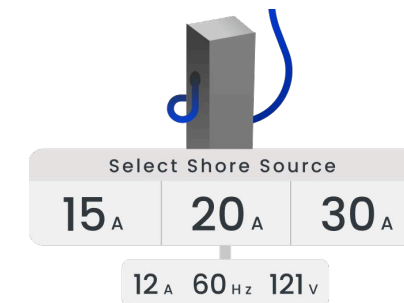

- If only **one line** is detected by the transfer switch, this menu will appear.
- **Select the shore breaker size**, and the EMS will automatically limit A/C power usage to match that setting.

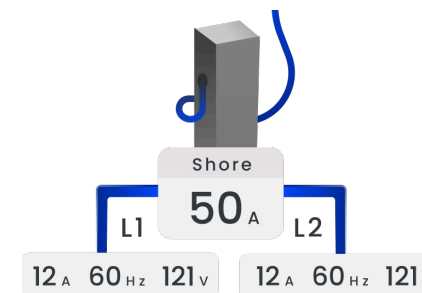

- If **two lines** are detected by the transfer switch **50A is automatically selected** as the shore breaker size.

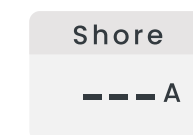

No AC Source

- If the box to the left is visible, no A/C source is detected by the transfer switch or EMS has been disabled.

# Power

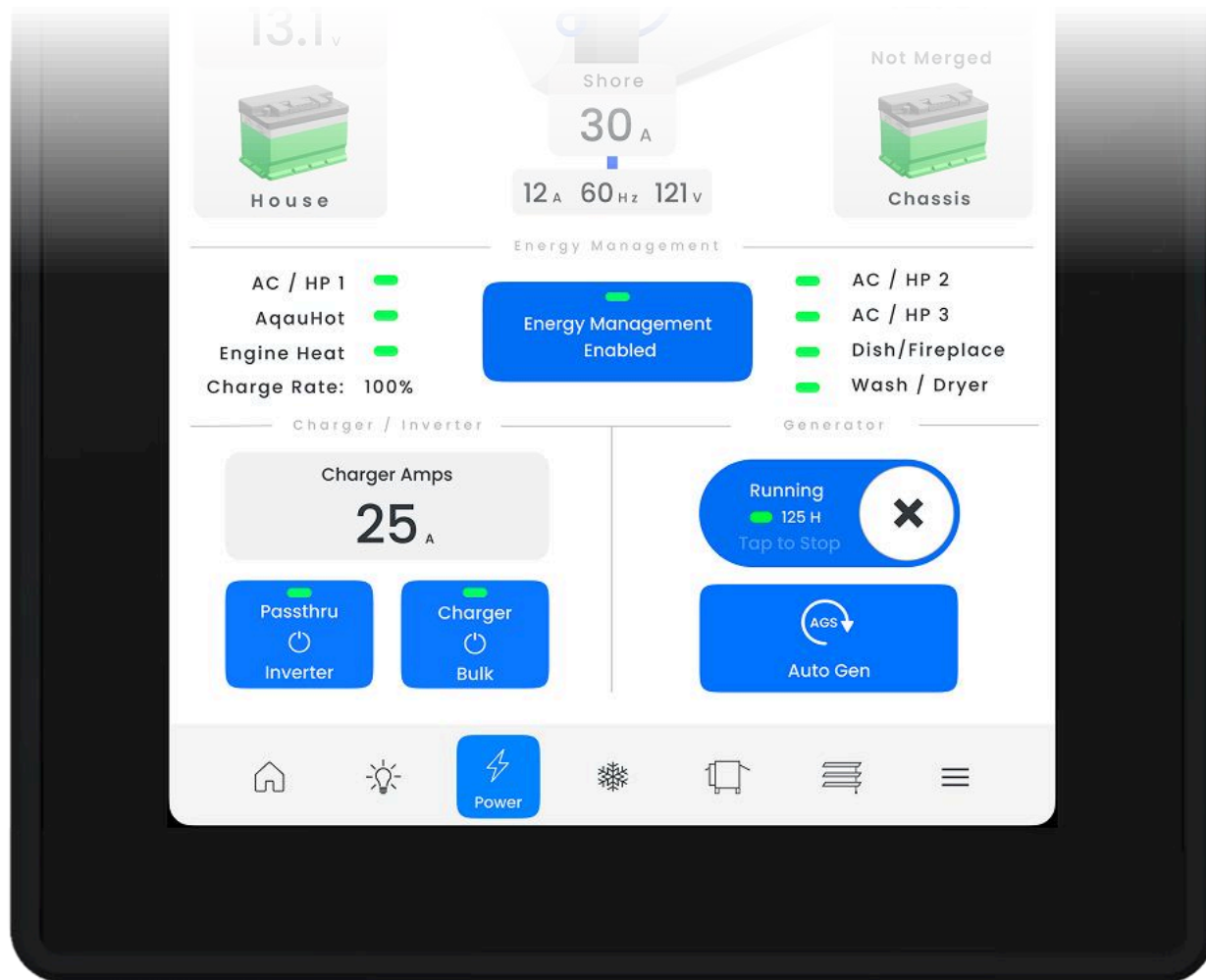

- **DO NOT** turn the Charger Off unless specifically requested to by a Tiffin Certified Tech or other RV / Inverter / Battery professional. Shutting the Charger off means the House Batteries **CANNOT** Charge. This can lead to severe damage or battery failure as well as damage or failure of devices on the DC 12V system.

- Contact Tiffin Motorhomes for further questions on the I/C (Inverter Charger) in your motorhome.

## EMS (Energy Management System)

- The **EMS (Energy Management System)** is software that prevents you from accidentally drawing too much A/C power and tripping the shore or generator breaker.
- To accomplish this EMS **Sheds** loads in order of priority.
- To **Shed** a load means the Spyder system is temporarily turning off shore power to an A/C load. Once sufficient A/C power is available the load receives A/C power again.
- Loads that can be **Shed** appear on a list in order of priority on the power page
  - Load On / Ready
  - Load Shed / Off
- EMS can be disabled by pressing the EMS button, it is recommended to leave EMS enabled (blue) to prevent accidental shore or generator breaker trips.
- EMS can affect the Inverter / Charger **Charge Rate**. To help reduce A/C current draw the EMS will lower the charge rate of the batteries temporarily.
- When toggling a load that can **Shed** you will notice the button flash off/on before becoming solid blue (on). This flashing is the EMS system ensuring there is sufficient A/C power to operate the load you are requesting to turn on.

## Inverter Assist

- On rare occasions you may notice a large negative current draw on the house batteries while you are connected to shore or running the generator. This state is called **Inverter Assist**.
- Inverter assist is a state in which power is temporarily drawn from the batteries to keep EMS loads from shedding.
- If the following is **TRUE** inverter assist will activate:
  - Shore or generator power is available
  - The charger is in **Float Mode** (batteries close to full)
  - The charge rate has been reduced
  - A non-EMS inverted load is activated, such as a microwave or hair dryer.

## Inverter / Charger

- It is easy to be confused with where the Spyder System starts and stops. The **Inverter / Charger (I/C)** is one of these points of confusion.
- Information, settings, charge status, inverter status all come from the **I/C** the Spyder system does not decide these. The Spyder LCD is a display for this information.
- When you toggle the inverter on/off or adjust a **I/C** setting in the **Power Settings Page** you are directly communicating with the **I/C** through the Spyder LCD.

# Power

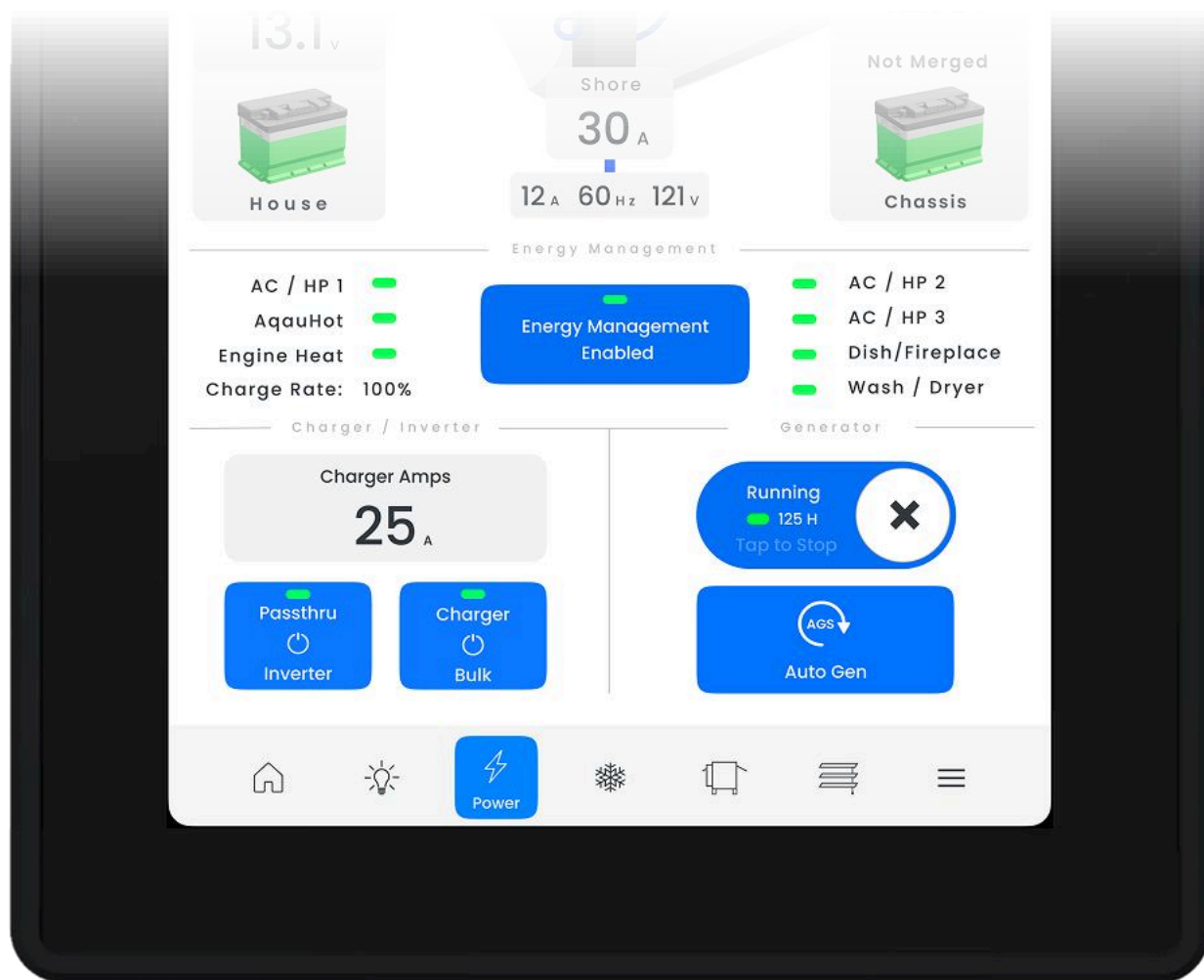

## AGS (Automatic Generator Start)

- **What is AGS?** AGS or **Automatic Generator Start** is software built into the Spyder system that starts and stops the generator on predefined user configurable settings.
- **How do I change AGS settings?** To change AGS settings or setup AGS for the first time locate an AGS button (On the Home Page or Power Page) press the button.
- A pop-up will appear. Press **Easy Setup** if you have not setup AGS before press **Manual Setup** to quickly adjust AGS settings.
- **How do I know if AGS is enabled?** If the AGS button is solid **blue** AGS is **enabled** and will start the generator and run the generator as per the conditions set by the user. If the button is **grey** the AGS is **disabled** and will not start or stop the generator.

AGS Enabled



AGS Disabled

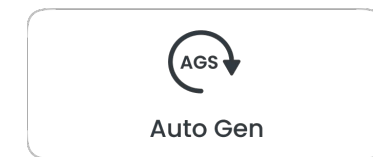

## Setting Up AGS

### AGS Popup

#### Auto Generator Start

AGS (Auto Generator Start) allows you to set parameters that your generator will follow.

Swipe the AGS enable button below to enable AGS, if this is not blue AGS is not active.

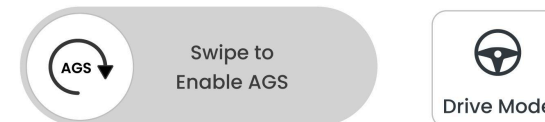

Pressing drive mode will allow you to drive with AGS enabled. If you do not select this AGS will disable automatically when the park brake is released

To setup AGS use the buttons below. Easy Setup is recommended if you have not setup AGS before.

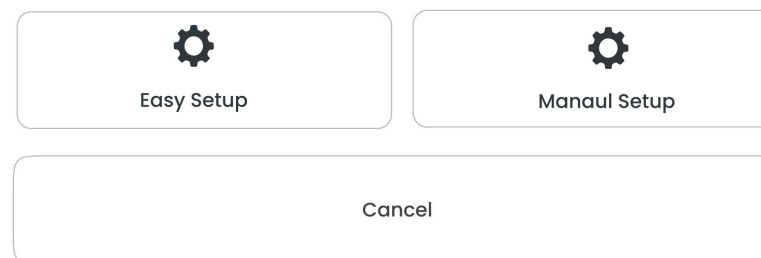

- **Enabling AGS** to enable AGS grab the circular toggle with AGS icon in it and swipe to the right.
- **Drive Mode** allows the AGS to stay enabled when you drive the motorhome. This allows AGS to start the generator automatically while you are driving.
- Tap **Drive Mode** to enable, note that AGS needs to be enabled for **Drive Mode** to work.
- Press **Manual Setup** to quickly adjust AGS settings without going through the guided setup menu.
- Press **Easy Setup** if you have not setup AGS before, once you press the button follow the on screen instructions to setup AGS

## Starting The Generator

- To **start** the generator tap the circular toggle with the power icon in it and drag it to the right.
- The generator will attempt to start, when the generator starts **running** the button will turn blue.
- To **stop** the generator press the X icon in the circular toggle.

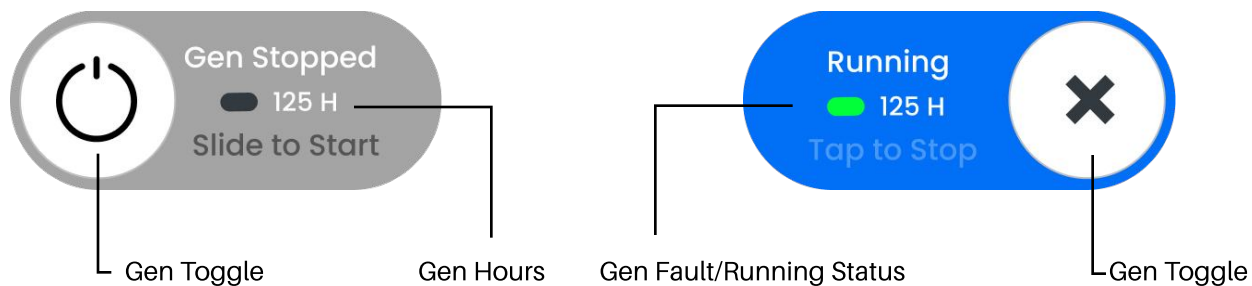

 **Do Not** Use AGS in a confined space. Doing so will cause injury or death. Do not enable AGS if you are in a confined space or an area with poor ventilation.

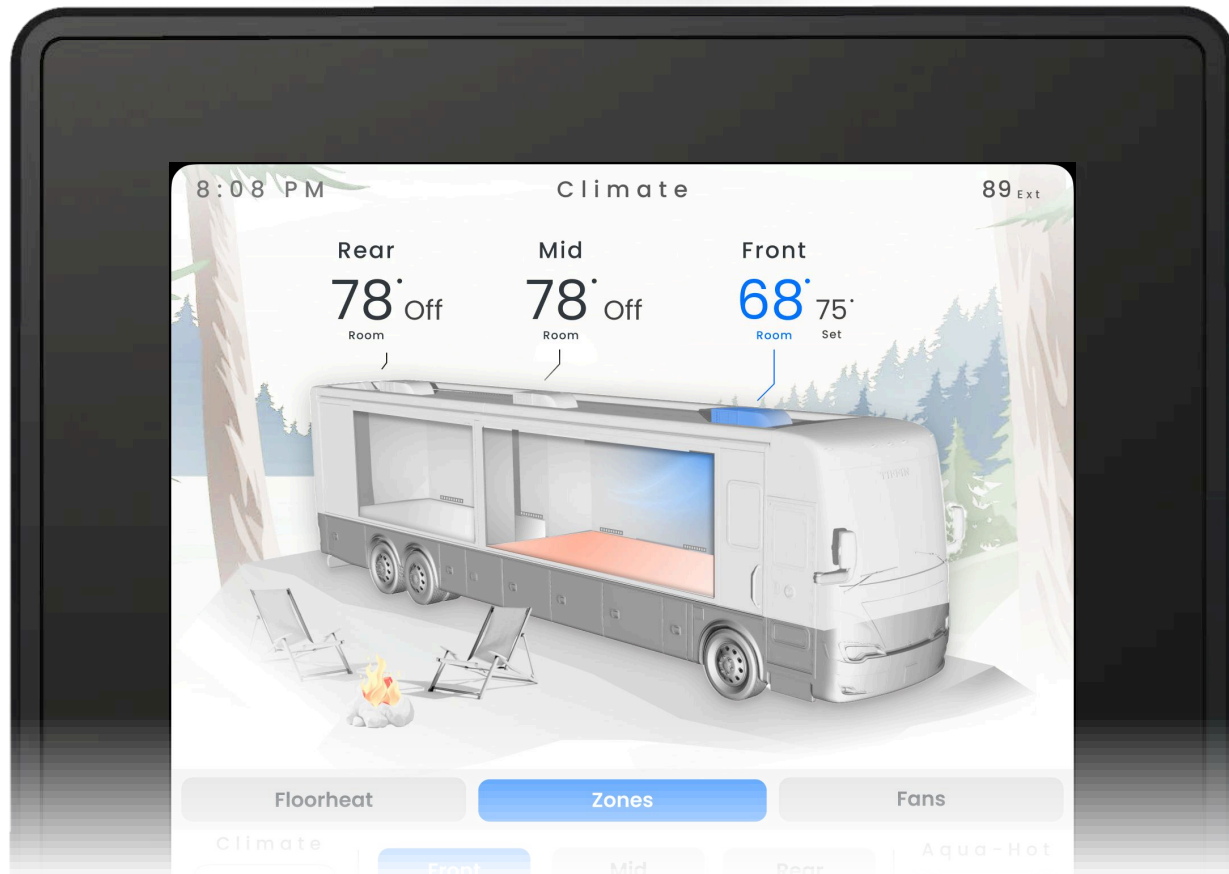

## Climate 3D Model

- This model displays HVAC status for all climate zones in your coach.
- Each zone has a name, set temperature, and ambient temperature. If a zone is heating the room temperature will be colored red, if the zone is cooling the room temperature will be blue.
- A climate **Zone** is an area in the coach acted on by the HVAC system. Your coach has three climate **Zones** (Front, Mid, Rear). Each zone represented in the 3D model has a set temp and room temp above it.
- The room temp is the larger of the two numbers, the room temperature number will change between Red (Heating), Blue (Cooling), Grey Off/Standby.
- The set temp is the smaller of the two numbers and represents the desired temperature for the zone that the HVAC system is trying to reach.

Rear <b>78°</b> off Room	Rear <b>78°</b> 75° Room Set
--------------------------------	------------------------------------

## Understanding Climate Status

- A/C units, floorheat, furnace, and heat pump are all displayed in this 3D model.
- Items that are cooling will show **Blue**. Items that are heating will show **Red**.

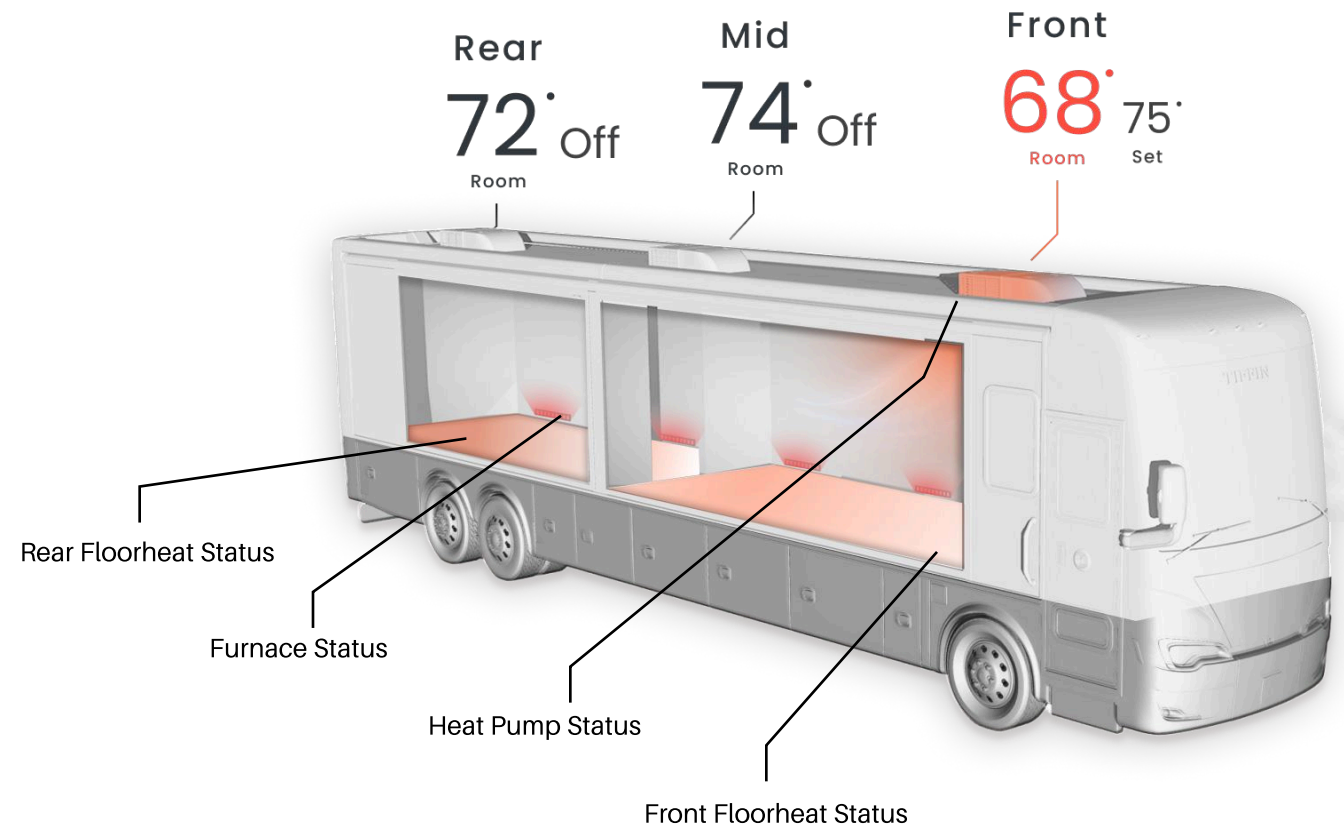
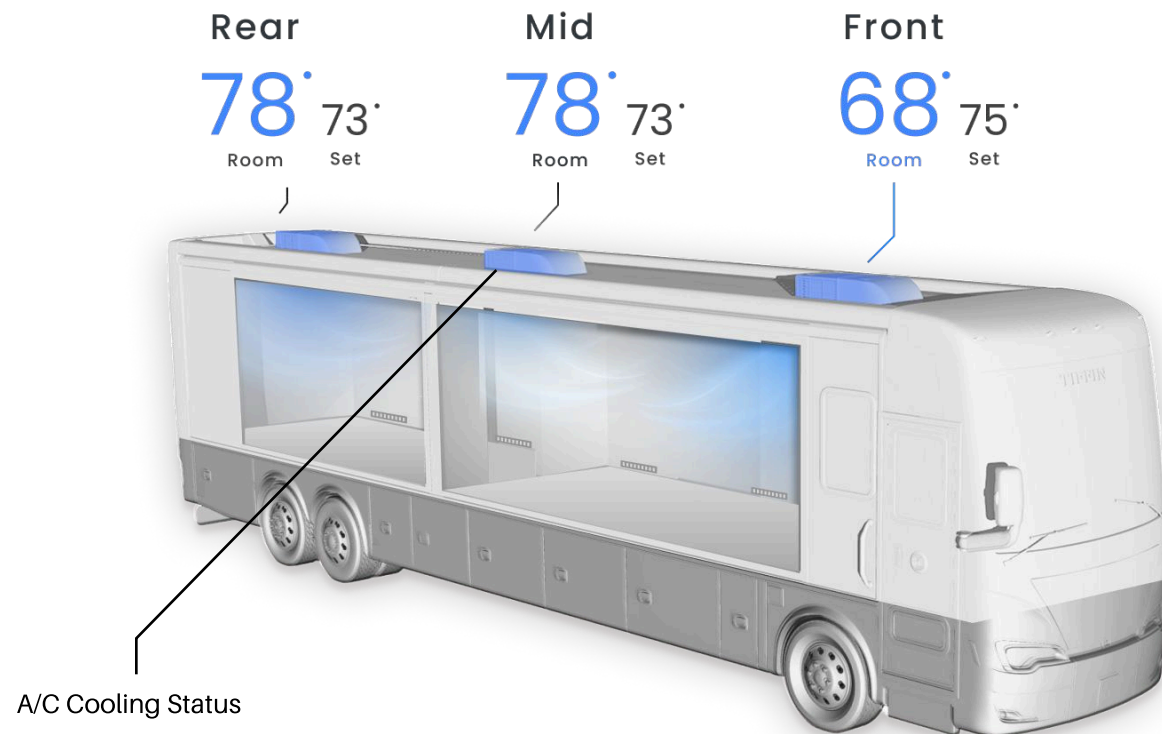

# Climate

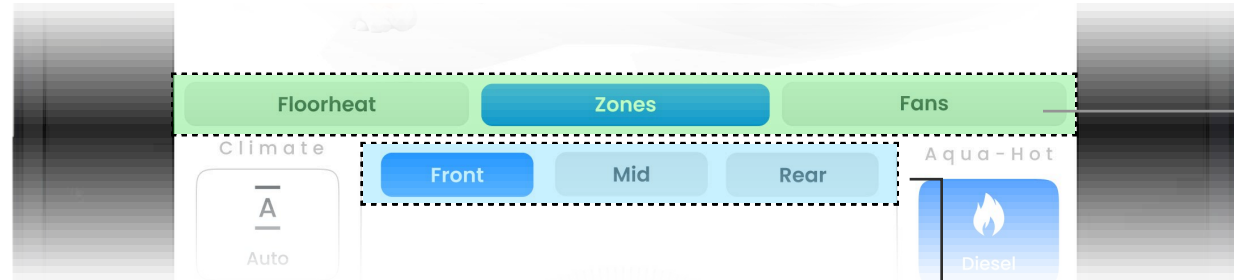

## Climate Navigation

- Use this bar to navigate between the major climate systems in the coach (Floorheat, Zone, Fans)

## Zone Selection

- Tap on the desired zone to change the which climate zone you adjusting.

## Climate Modes



- Auto** mode lets you set a minimum "Heat At" and maximum "Cool At" temperature. The system automatically uses the furnace, heat pump, or A/C to maintain the room/zone temperature between these two points.



- Press the **A/C** button to turn the air-conditioner on for the selected zones. Dragging the the cool toggle on the thermostat arc adjusts the set temperature for that zone.

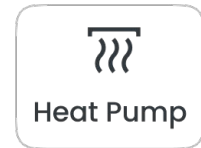

- Pressing the **Heat Pump** button activates the zone's A/C heat pump. Dragging the heat toggle on the thermostat arc adjusts the set temperature for that zone.



- Pressing the **Furnace** button will activate the furnace. For the furnace to operate you will need to select a furnace heat source.
- Tap the **Diesel Aqua-Hot** button or **Electric Aqua-Hot** button to enable the furnace. Dragging the the heat toggle on the thermostat arc adjusts the set temperature for that zone.

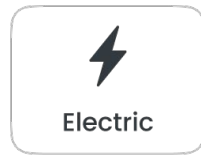
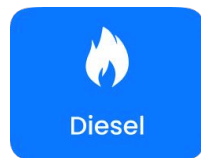

**Do Not** Use Diesel Burner in a confined space. Doing so will cause injury or death. Do not use the Diesel Burner if you are in a confined space or an area with poor ventilation. This applies to **Auto Mode** and **Furnace**.

The HVAC system cannot **Cool** in one zone and **Heat** in another. The HVAC system will automatically prevent this from happening.

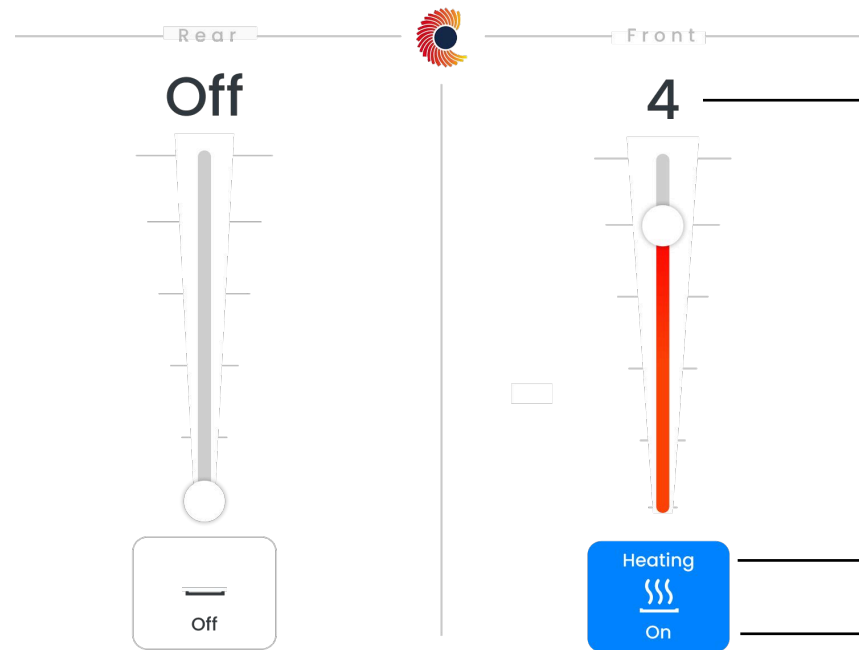

The current floorheat level is displayed above the slider.

- To adjust the floorheat level **tap and drag** the slider to the desired level.
  - Level 1 is the coolest — the floorheat heats until that range is reached, then turns off until it cools below it.
  - Level 5 is the warmest — the floorheat stays on longer to reach the higher temperature.

To toggle the floor heat on and off tap the floorheat button.

The heating status of the floorheat displays here.

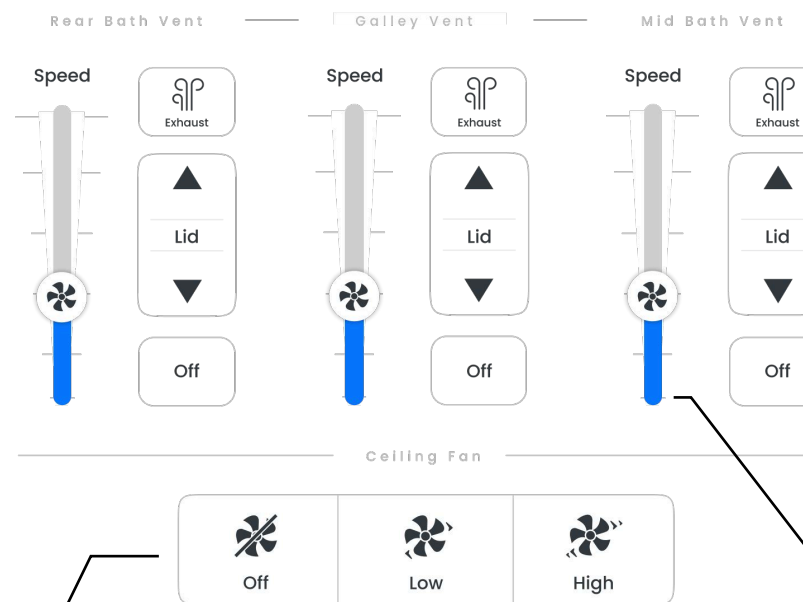

- Navigating to the Fans page shows controls for all vent fans and the ceiling fan in the coach.

Certain vent fans can have the **airflow** direction adjusted. To adjust the airflow direction tap the exhaust/intake button.

To **open** the vent lid tap the ▲ button.

To **close** the vent lid tap the ▼ button.

- To crack the vent fan lid open a bit press and hold the lid open button then release it at a desired level.

To turn the fan off tap the **off** button.

To adjust **fan speed**, drag the toggle all the way up for full speed, all the way down to slow it down and turn it off.

If your coach has a ceiling fan, tap a speed setting to adjust it or tap **Off** to turn it off.

# Climate

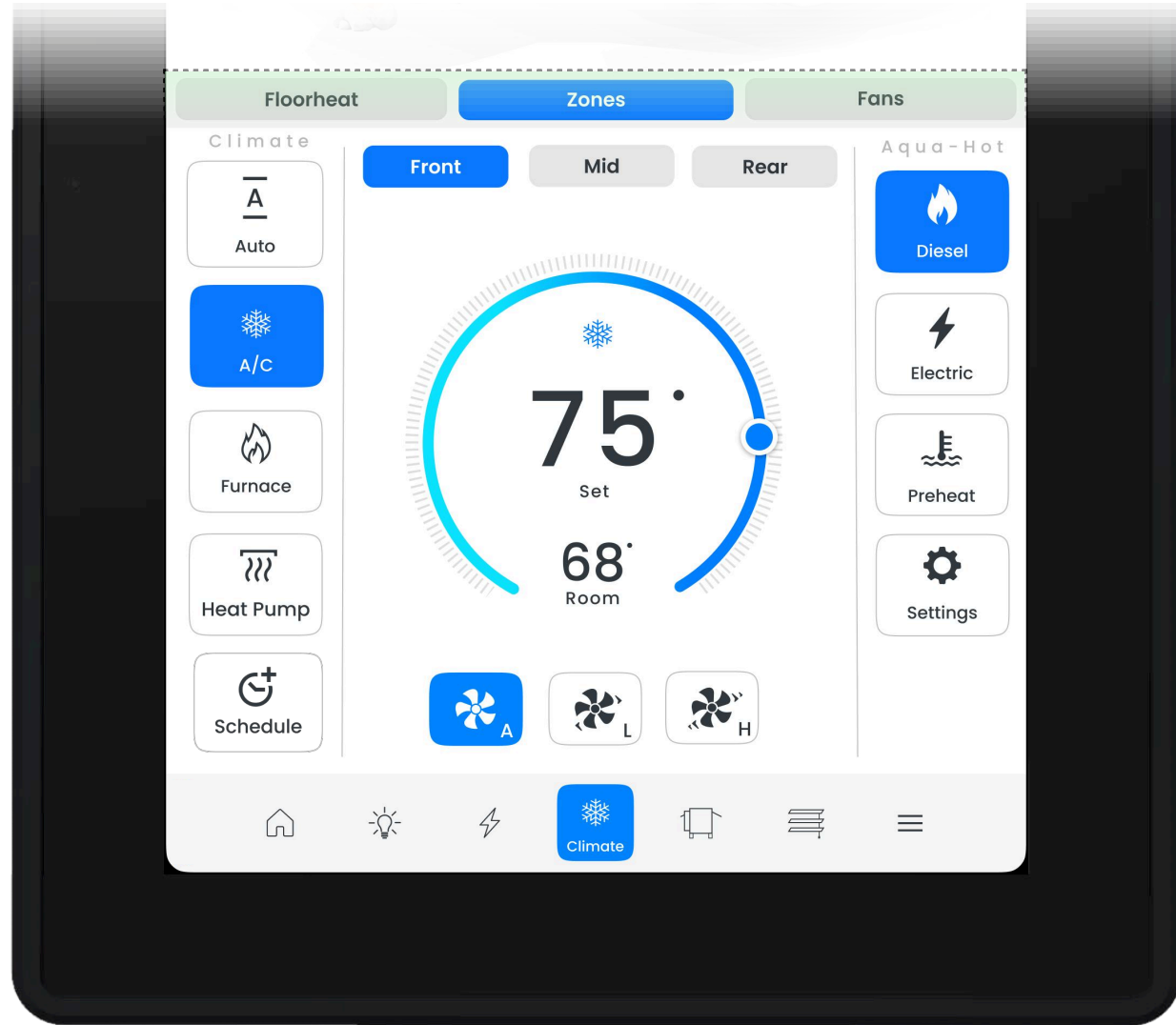

## Scheduler

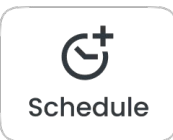

- To set up a new HVAC schedule or edit an existing HVAC schedule tap on the Schedule button.
- The follow the on screen guided schedule setup by pressing **Guided Setup** once on the schedule page.

## Aqua-Hot

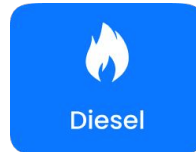

- Pressing **Diesel** will turn on the diesel burner on the Aqua-Hot unit. The button will flash on/off until the **Diesel Burner** ignites.



- Pressing **Electric** will turn on the electric heat element on the Aqua-Hot unit. The button will flash on/off indicating it is in **Shed**. Once the button stays solid blue the electric element is on and heating.

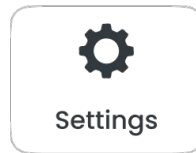

- To adjust Aqua-Hot **settings**, view Aqua-Hot Diagnostics, or enter Aqua-Hot test mode press the settings button.



- To turn on the Aqua-Hot engine preheat press this button.

## A/C Fan Controls & Temperature Units



- Tap High or Low to set the A/C Fan to that level.
- To adjust **Temperature Units** between C/F navigate to the settings page.

- The A/C fan defaults to **Auto** during operation, in this state the the A/C will automatically switch between High and Low depending on the Room Temp and Set Temp.

## Thermostat Arcs

**Thermostat Arc**

HVAC Status

- **Flame** = Furnace
- **Wavy Lines** = Heat Pump
- **Snowflake** = A/C
- **Fan** = A/C Fan

Thermostat Arc

- The thermostat arc will change based on the selected **HVAC Mode**.

Zone Room Temperature

85° Set

68° Room

**Sync**

- Pressing this will **Sync** all three zones to the current Zones set temperature and HVAC mode.

Thermostat Toggle

- Drag this to adjust the **Set Temp**

Zone Set Temperature

**Auto Arc**

I want the rear zone to stay between

65° & 72°

70° Room

Drag this to adjust the **Heat At point**

Drag this to adjust the **Cool At point**

This is the range the HVAC system will maintain by heating and cooling the coach.



## Slide Safety

- To operate the slides safely the **Ignition** must be **On** and the **Park Brake** must be **Set**.
- If the coach is equipped with a Fireplace, the Fireplace must be off in order for the rear slides to retract.
- The Slide safety requirements are clearly visible on the top left of the mech page.

**Ignition not present /  
Slide will not operate**



Ignition

**Ignition present /  
Slide will operate**



Ignition

- A warning will appear in the top right area of the slides page explain why the slide will not move.

## Front Slide Overrides

- If the slide switches on the driver or passenger seats fail to extend or retract the slides the slides can still be extended and retracted from the 10" LCD.
- To run the front slides from the 10" LCD press the **Front Slide Override** button. Once the button is pressed new slide controls will appear for the front slides.
- To operate the slides in this situation you must hold a slide extend or retract button for **ten seconds** before the slide will begin to move. A countdown timer will appear in the top right of the slides page.

## Slide Control

- To extend a slide **Press and Hold** the slides extend button. To retract a slide **Press and Hold** the slides retract button. The slides are color coded to the corresponding slide button.
- A gentle touch is all that is required to extend or retract a slide. The button will illuminate solid blue when the slide is moving.



- Excessive hard pressing and holding may damage the LCD.



## Awning Safety

- To operate the awnings safely the **Park Brake** must be **Set**.
- The awning safety requirements are clearly visible in the center left of the mechanical page.
- A warning will appear in the top right area of the mech page explain why the awning will not move.

## Awning Control



- To extend a awning **Press and Hold** the awning extend button. To retract an awning **Press and Hold** the awning retract button. The awnings are color coded to the corresponding awning button.
- A gentle touch is all that is required to extend or retract a awning. The button will illuminate solid blue when the awning is moving.



- Excessive hard pressing and holding may damage the LCD.





## Locks

- To lock a door press the  icon. To unlock a door press the  icon.
- The awning safety requirements are clearly visible in the center left of the mechanical page.
- A warning will appear in the top right area of the mech page explain why the awning will not move.

## TV Lift

- Press  to lift the TV. To lower the TV hold .

## Bed Lift

- If the coach is equipped with a non-automatic bed lift it will be controlled from this page.
- Press  to lift the bed. To lower the bed .

# Shades

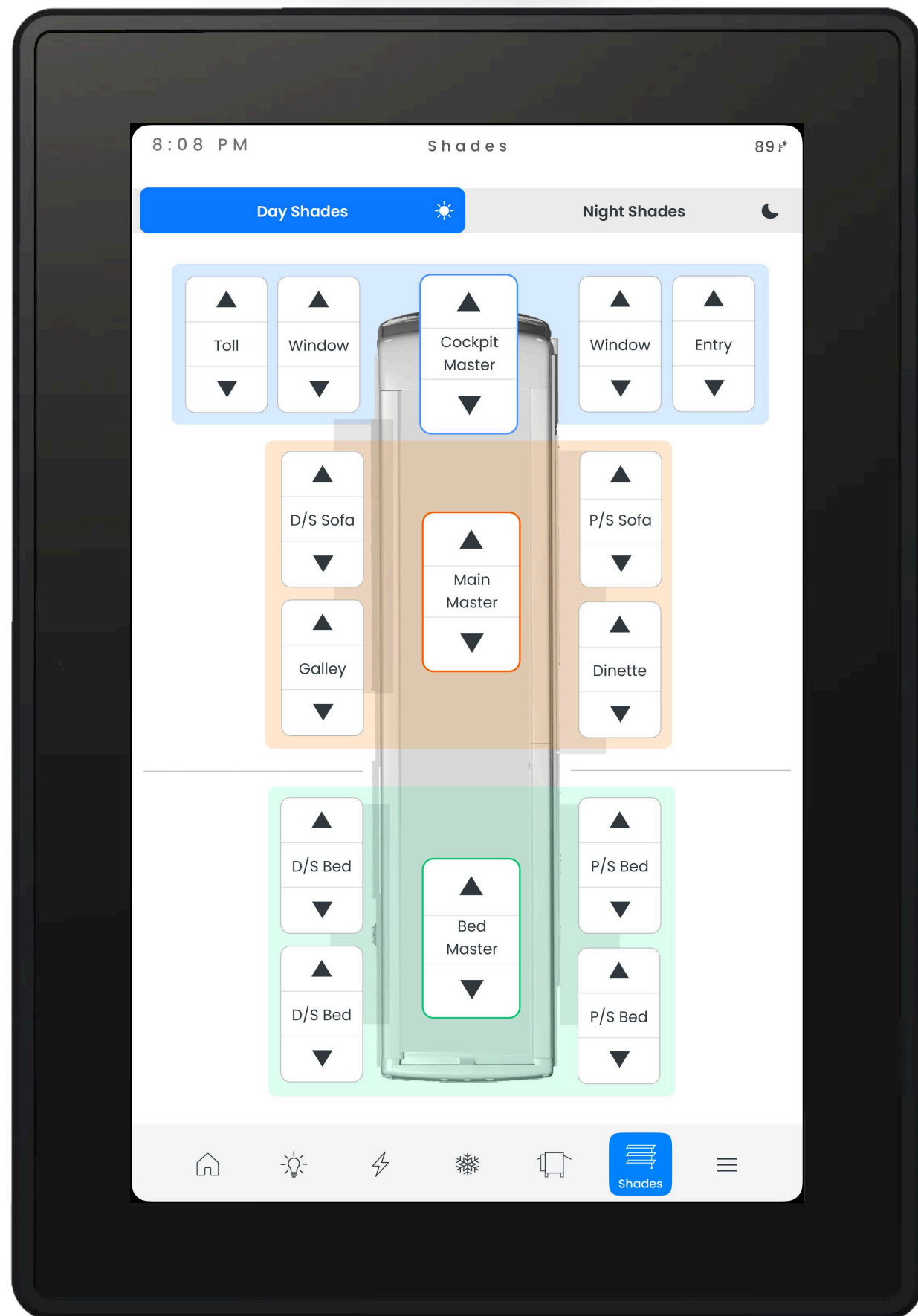

## Shades Navigation

- To change between the Day and Night shades tap on the corresponding tab.

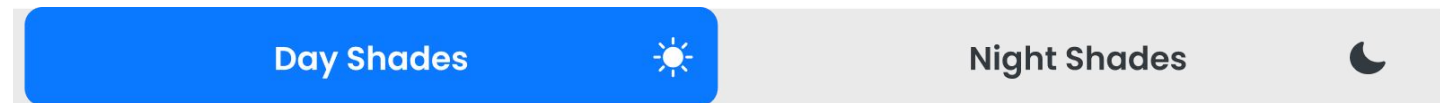

## Shade Masters

- On the shades page shades are divided into three zones based on their location in the coach.
- Shade masters control all shades in a given zone, and are found in the center of the zone.

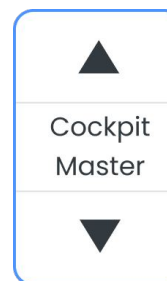

- To raise all shades in a zone press the ▲ icon.
- To lower all shades in a zone press the ▼ icon.

## Shade Control

- To control an individual shade press the ▲ icon to raise the shade. Press the ▼ icon to lower the shade.
- To raise or lower a shade to a desired level **press and hold** the raise or lower button, then **release** once the shade is at the desired height.

# Settings

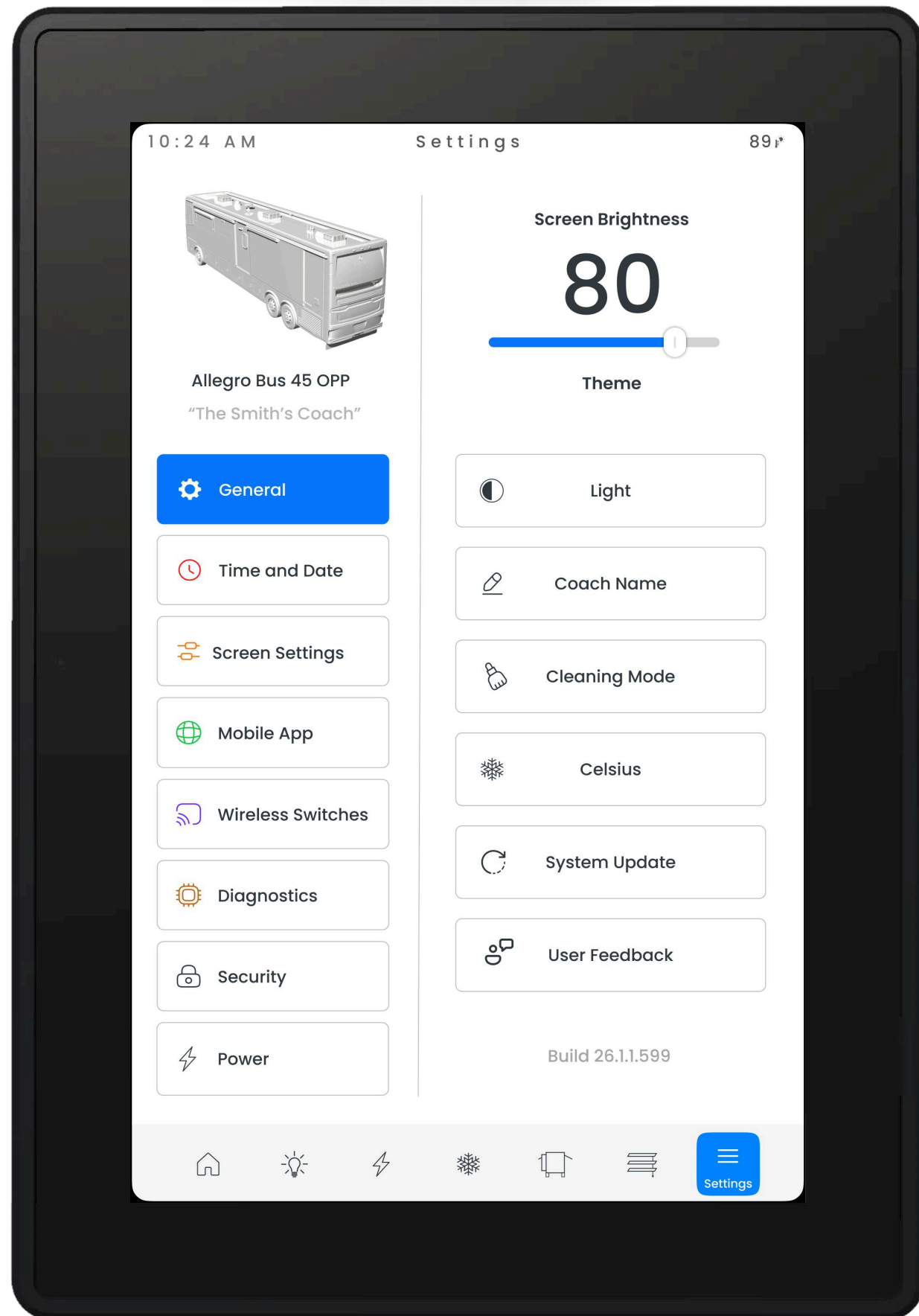

## Settings Navigation

- The settings page is divided into two columns.
- The column on the left shows a 3D model of the coach, the coach model, and the coach name.
- Below the coach model on the left column is a list of main settings pages.
- Tapping a main setting page button in the left column will cause the column on the right to populate with settings relevant to the main settings page selected.
- The main settings pages and content are as follows.
  - **General:**
    - Adjust **Screen Brightness**. Drag the screen brightness toggle to the desired screen brightness.
    - Adjust **Theme** between light mode and dark mode. See **Fig. 1**.
    - Change the **Coach Name**. This displays on the exterior 5" LCD.
    - Enter **Cleaning Mode**. This disables touch on the screen temporarily to allow you to clean it.
    - Toggle the HVAC **Climate Unit** between Celsius and Fahrenheit.
    - The **System Update** button is rarely used, under normal circumstances pressing this button will scan and report that the system is up to date. Generally the Spyder system does not need to be updated, contact Spyder Controls for more information.
    - Tap **User Feedback** to provide useful feedback on your experience with the Spyder user interface and the Spyder Controls system in general.

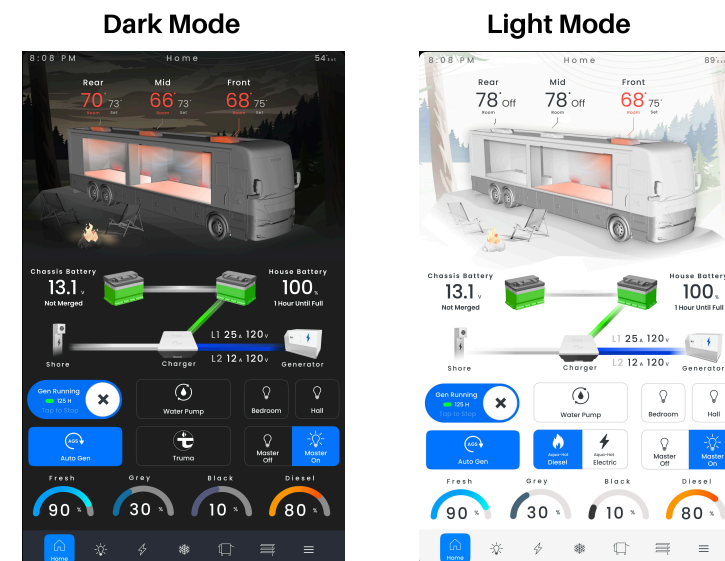
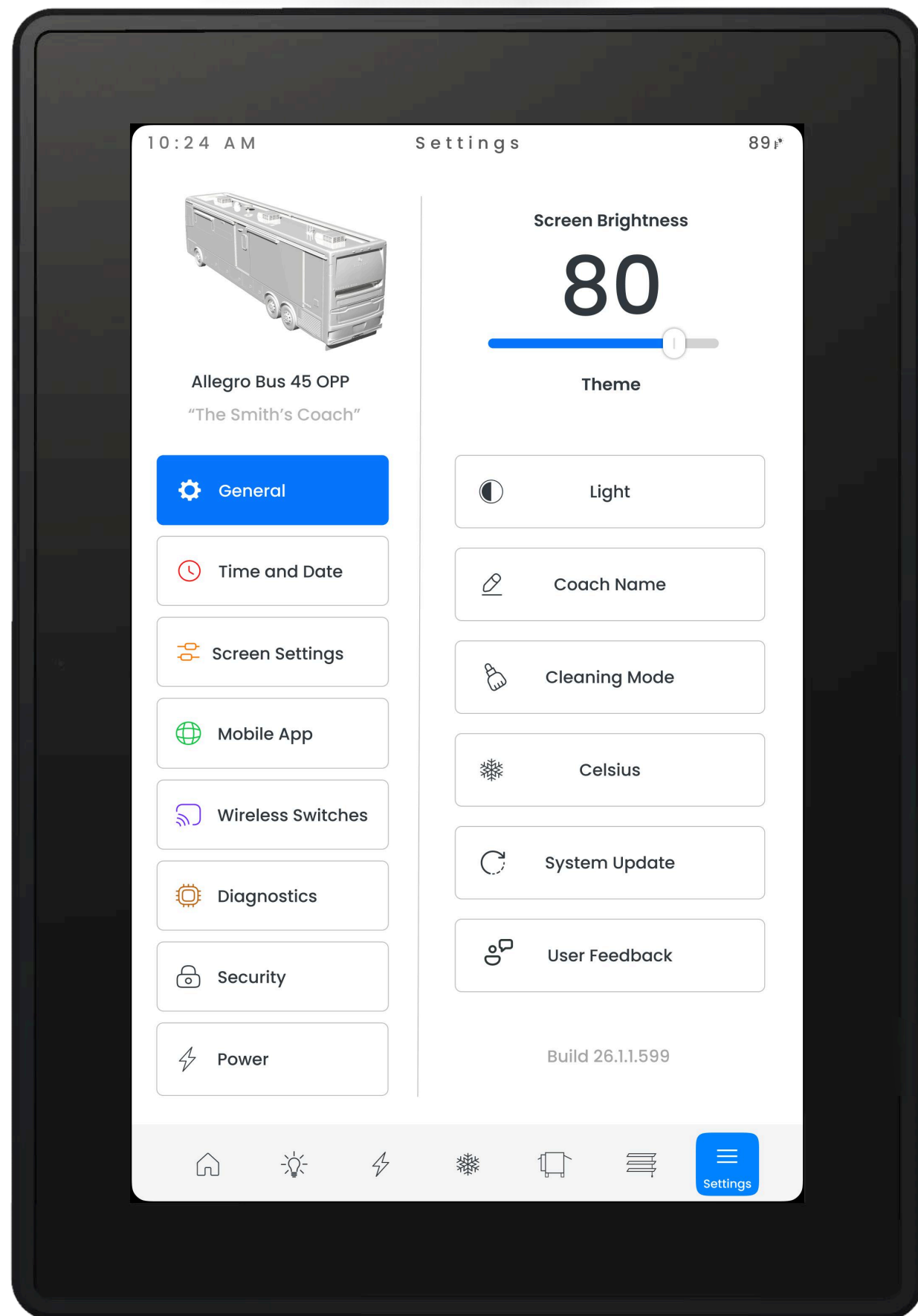

Fig.1

- **Time and Date:**
  - You can adjust the **System Time** and **System Date** here.
  - It is very important to keep the time and date correct as systems like **AGS** use it.

# Settings



## Settings Navigation

- **Screen Settings:**

- After a period of inactivity the LCD screen will **Sleep**, you can adjust this period between 1 and 20 minutes. The screen will shutoff when it enters sleep, tap anywhere to turn it back on.
- The **Default Page** and the amount of time before the screen returns to it can be adjusted here.

- **Mobile App:**

- To complete setup for the Firefly Integrations mobile app (Mira or Eclipse) tap on this page. The **Pin Code** and **Pairing ID** can be found here as well as QR codes to download the Mobile App.

- **Wireless Switches:**

- To **pair, unpair** and view **battery status** for the various **wireless switches** and **key fobs** navigate here.

- **Diagnostics:**

- The diagnostics page is primarily used for troubleshooting purposes. A Spyder Tech may ask you about information displayed on this page.

- **Security:**

- Navigate to this page to adjust your **Exterior Door Pin Code**, adjust the volume or disable the of the **Doorbell**, and toggle the **Headlight Flash**.

- **Power:**

- Tap this to adjust **Solar Controller Settings**, **Trustate Settings** this is the battery type and bank size, and **Inverter/Charger Settings**.