

# CON 17

**1.** Before any of the following steps are to be considered several prerequisites for normal operation of the 250D

These include:

- Valid thermistor readings from all zones
- G6 Panel must be on green NET LED
- Control Interface (LCD) must have a green NET LED
- The Aquahot 250D must be powered

**2.** Once all the prerequisites in step one have been verified the first step in the Aqua-Hot running order can be assessed.

In order for the 250D to start we must detect a valid level of Glycol in the Aqua-Hot unit.

- The 250D measures this fluid level and provides a 12V+ output from AH Pin 4 to G6 CON 14 Pin 4.
- The 250D measures this fluid level and provides a 12V+ output from AH Pin 4 to G6 CON 14 Pin 4.

**AQUA-HOT**  
**LOW COOLANT LEVEL**

This fault will appear if low a low coolant level is detected.

### 3. If the conditions in step 1 and step 2 are met the AH 250D should be ready to fire the diesel burner. The following steps assume that the customer is trying to ignite the diesel burner.

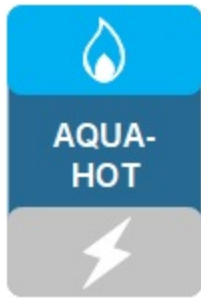

When the button is pressed it will illuminate blue to indicate the burner is trying to ignite.



If the burner icon turns red after a short time a fault is being indicated by the 250D

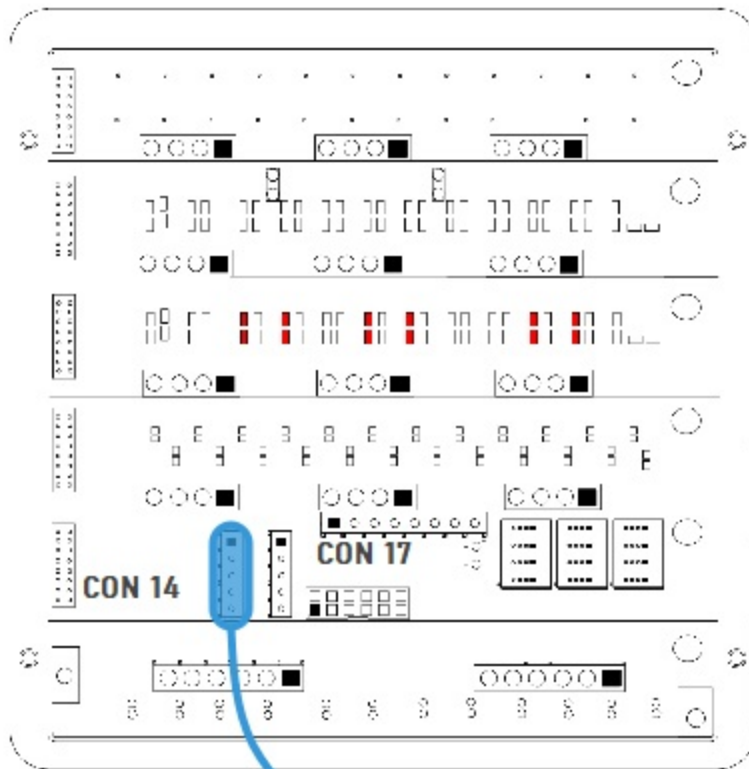

- The first point to check is the AH connector found at the AH 250D. Check pin 11 for 12V+
- If you **don't** have 12V+ on Pin 11
- Contact Aqua-Hot, there may be an issue with the AH 250D
- If you **do** have 12V+ on Pin 11
- Check to see if you have 12V+ on the back of the G6 panel con 14 Pin 1.
- If you **do** have 12V+ on Conn 14 Pin 1
- Contact Spyder Controls, there may be an issue with the RSI-9
- If you **don't** have 12V+ on con 14 Pin 1
- The issue is in the wiring between the AH 250D and con 14 on the G6 panel

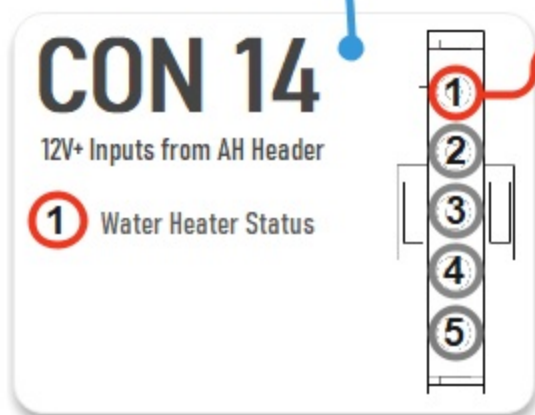

# 4. When the electric or diesel heat buttons are pressed on the Spyder LCD an output is turned on at the G6 house panel. Channel 23 for electric water heat, channel 24 for diesel water heat.

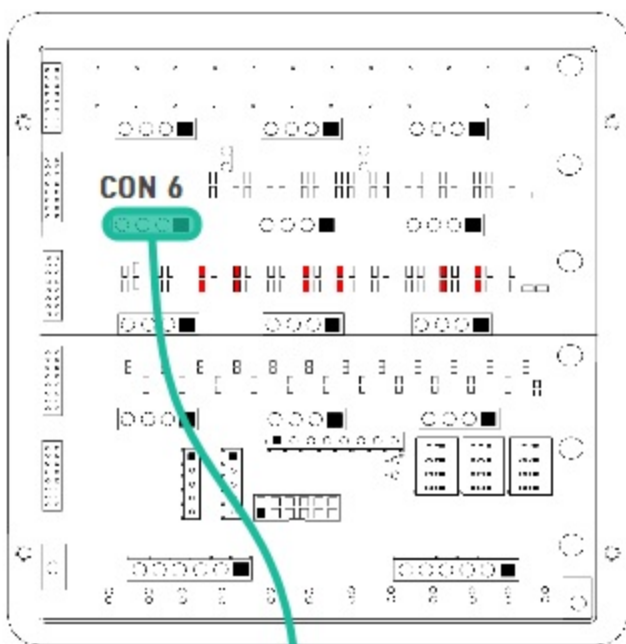

If one of the sources of water heat is not working and all steps before this have been checked.

- Ensure the correct LED is turning on at the G6
- Verify that 12V+ is being output from Con 6 pin 3 (electric) and pin 4 (diesel).
- If 12V+ is not being output from the G6 call Spyder.

LEDs on G6 Front



Electric Water Heat

Diesel Water Heat

Continued Below

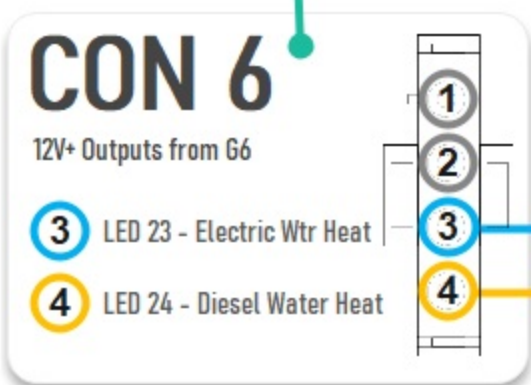

- If 12V+ is outputting from the G6 panel, check the respective inputs on the AH connector at the AH 250D.
- If you **do** power here the desired heater is not activating contact Aqua-Hot.
- If you **don't** have power here the issue is in the wiring.

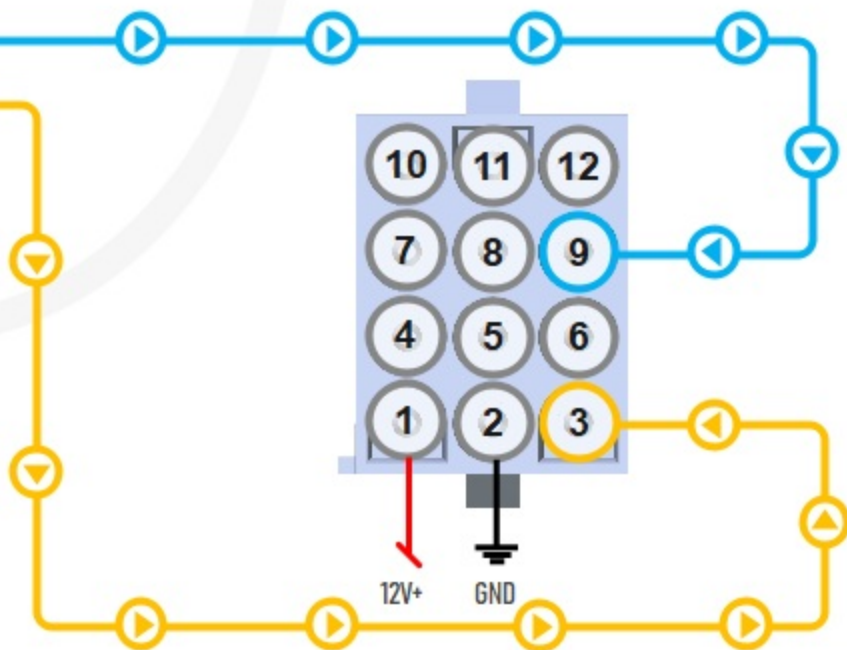

5. The next step assumes that the customer has pressed the furnace button on climate page and as set the set temp above the ambient temp.

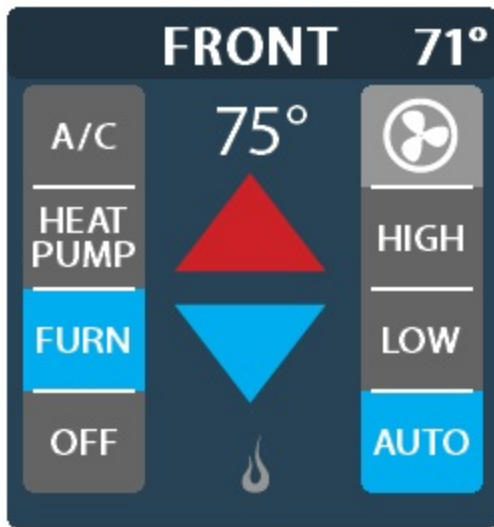

Once the furnace button is pressed and the set temp is above the ambient temp the furnace trigger will turn on.



- To check if the furnace trigger is active look at the LEDs on the front of the G6 house panel. LED 6 should be green.

- If LED 6 is not active, verify all the steps prior have been completed. If it still remains off contact Spyder.

- If LED 6 is on but the 250D is not outputting heat from the exchangers check the voltage from the pin on the back of the G6 panel Con 2 pin 2. If the G6 panel is not outputting 12V+ call Spyder.

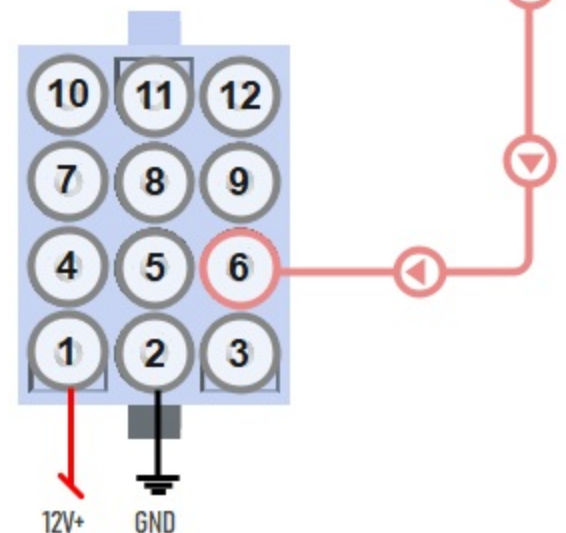
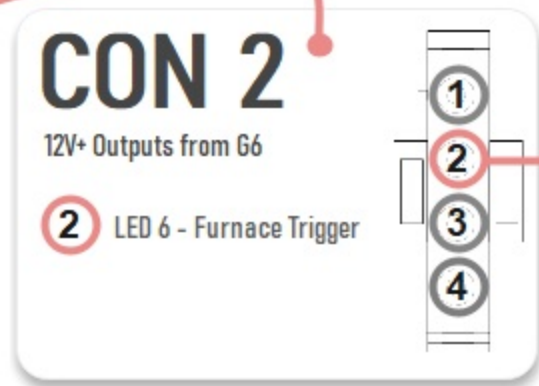
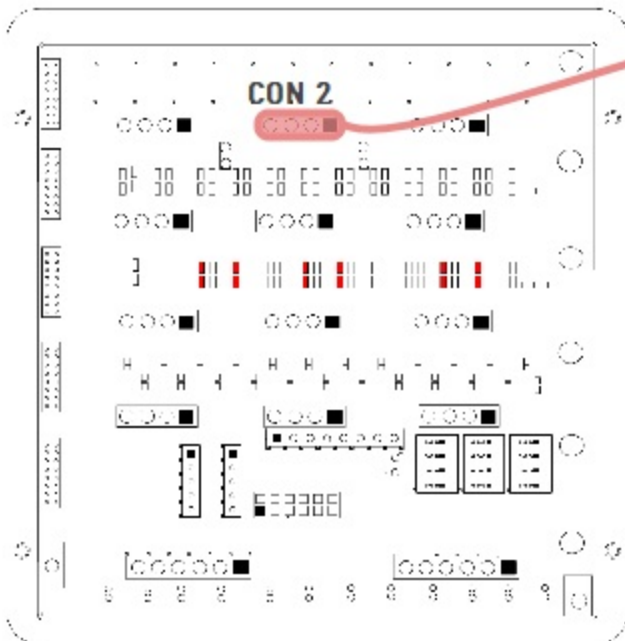

- If the G6 panel is outputting 12V+ check to see if the voltage is being received at the AH connector on pin 6.
- If you **do** have voltage here and the exchangers are not turning on refer to the next step.
- If you **don't** have voltage here the issue is in wiring.

**6.** This step assumes that you have 12V+ being input to the AH connector on pin 6. If you do not have this check the previous step.



Heat Exchanger Input **NOT** Provided

In order for the exchangers (Cozy Zones) to turn on, the AH exchanger input must be received to Con 14 Pin 3 on the back of the G6 panel.

As soon as this input is received our system will turn on the appropriate exchanger.

- If the exchangers are not coming on check for 12V+ being emitted from pin 7 on the AH header
- If you **don't** have voltage here, check step 5 again. If you still have no voltage contact Aqua-Hot
- If you **do** have voltage here and the exchangers will not turn on, check to see if you have 12V+ on con 14 pin 3 on the G6 panel
- If you **don't** have voltage here the issue is in wiring
- If you **do** have voltage here the issue may be in the RSI-9. Please contact Spyder

The heat exchanger input status on the LCD is represented by a red flame on the climate page.

If this flame does not change to red when the furnace turns on review step 5 and step 6.

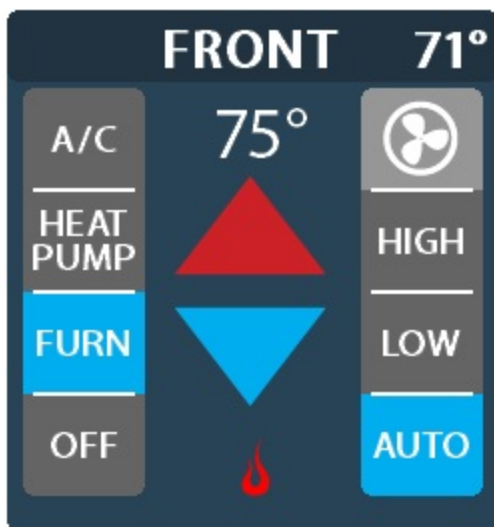

Heat Exchanger Input Provided

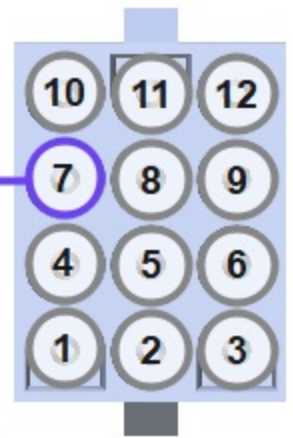
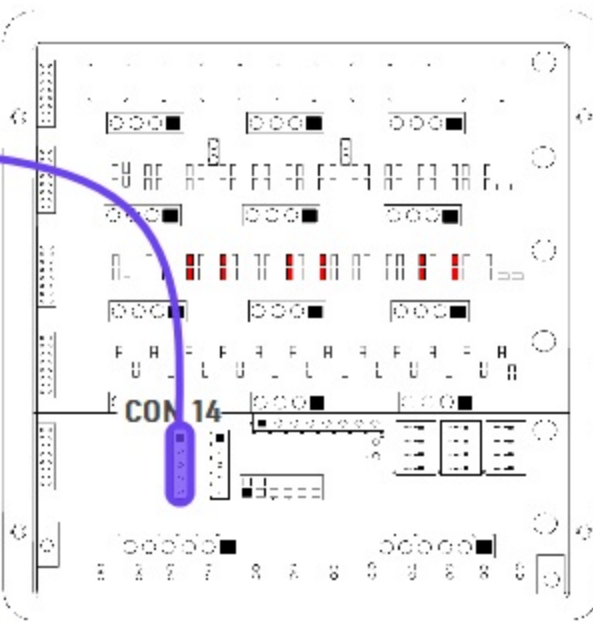
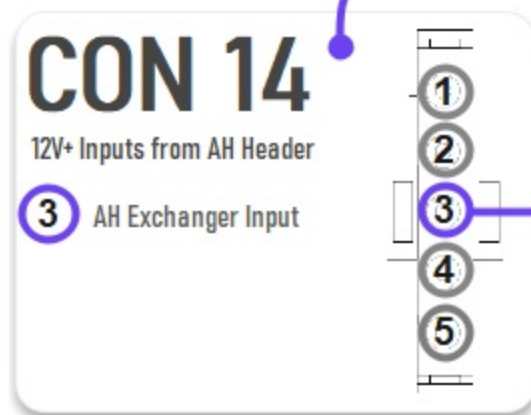

**7.** This step assumes that you have a heat exchanger input being received as described the previous step. This will result in a red flame icon in the climate zone as shown below. If you do not have this flame in the desired zone please repeat step 5 and 6.

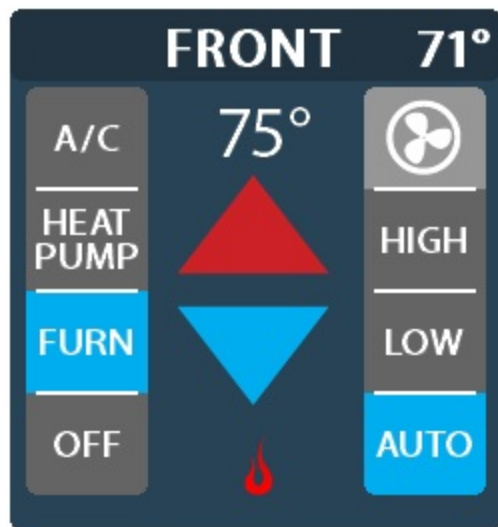

Depending on which furnace zone is turned on an LED will turn on at the G6 panel.

LED 19 for the front zone and LED 20 for the rear zone.

- If these LEDs are not coming on and you have verified the previous steps, please contact Spyder.
- If the appropriate LEDs are on but the desired exchanger is not on check con 5 pin 3 (front zone) or pin 4 (rear zone) for 12V+



- If you **don't** have voltage being emitted from either pin on con 5 please contact Spyder.
- If you **do** have voltage being emitted at the appropriate pin on con 5 but the exchanger zone is still not on check the voltage at the exchanger (Cozy Zone) fan.
- If you **do** have 12V+ here, contact Aqua-Hot.
- If you **don't** have voltage here the issue will be in the wiring to the exchanger (Cozy Zone)
- If you **don't** have voltage being emitted from either pin on con 5 please contact Spyder.

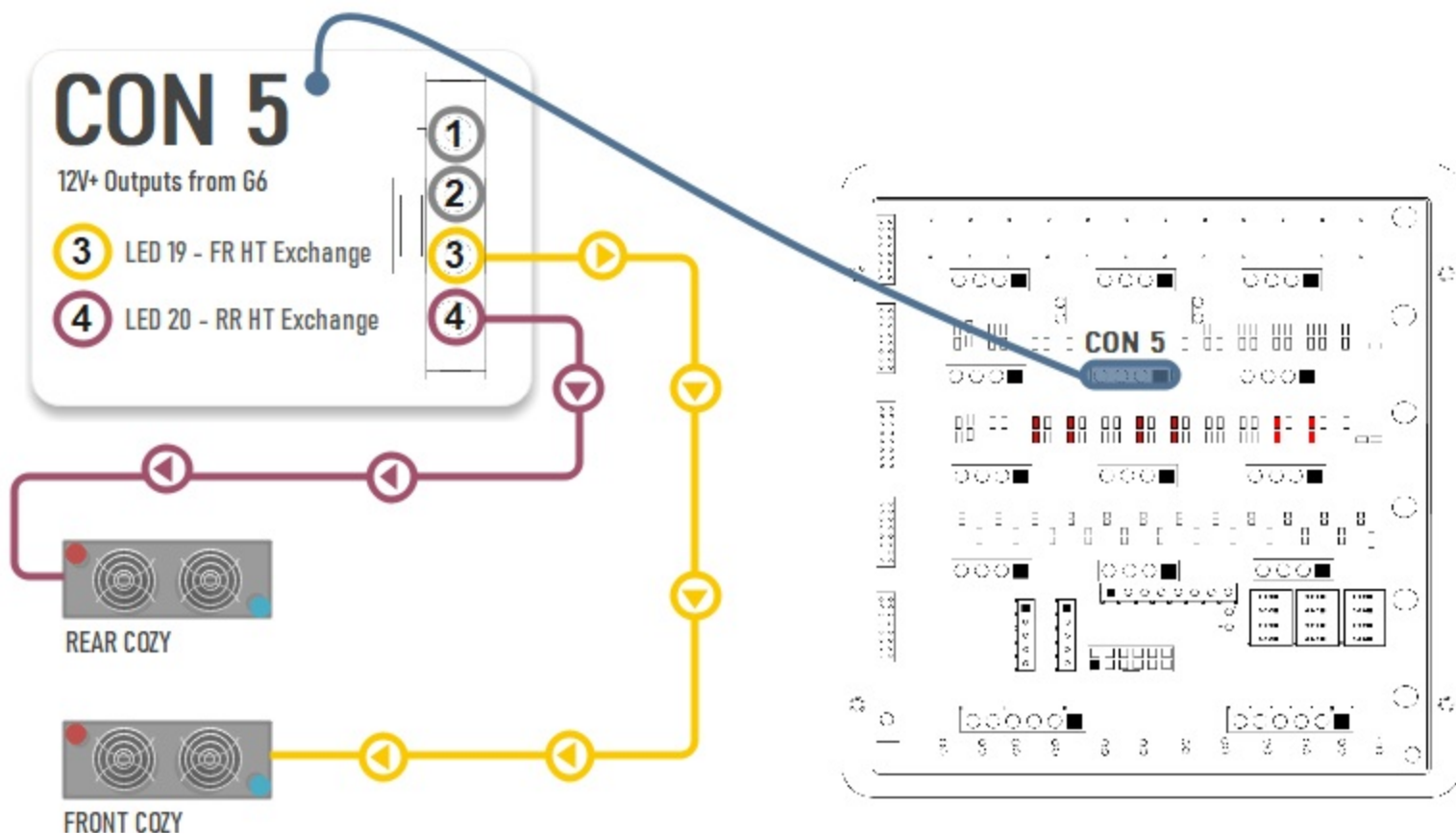

## 8. This step deals with the bay heat exchanger troubleshooting. If you do not have power to the heat exchanger input as mentioned in step 6 the bay heat exchanger will not work.

The bay heat exchanger differs from the front and rear zones as the bay set point cannot be adjusted.

The bay heat exchanger will turn on or off based on the temperature value reported by the bay thermistor.

LED 7 will turn on at the G6 panel when the bay heat exchanger turns on.

- If LED 7 is on but the bay exchanger is not on check con 2 pin 3 for a 12V+ output.

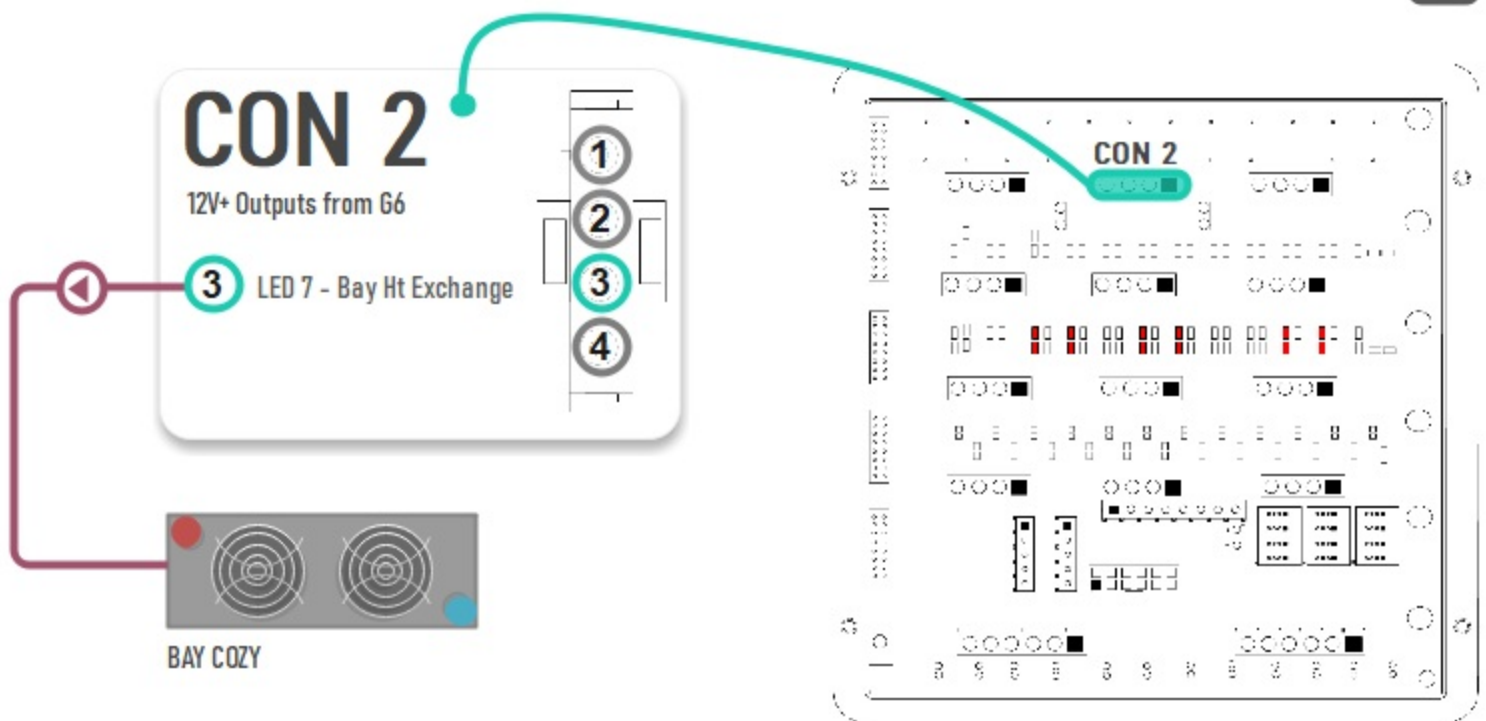

- If you **don't** have voltage being emitted from pin 3 on con 2, please contact Spyder.
- If you **do** have voltage being emitted at pin 3 on con 2 but the bay exchanger zone is still not on check the voltage at the exchanger (Cozy Zone) fan.
- If you **do** have 12V+ here contact Aqua-Hot.
- If you **don't** have voltage here the issue will be in the wiring to the bay exchanger
- If you **don't** have voltage being emitted from either pin 3 on con 2 please contact Spyder.



- 9 This step deals with the boost pump troubleshooting. The boost pump is installed to assist in the circulation of the glycol heating fluid from the AH 250D to the Cozy Zones.

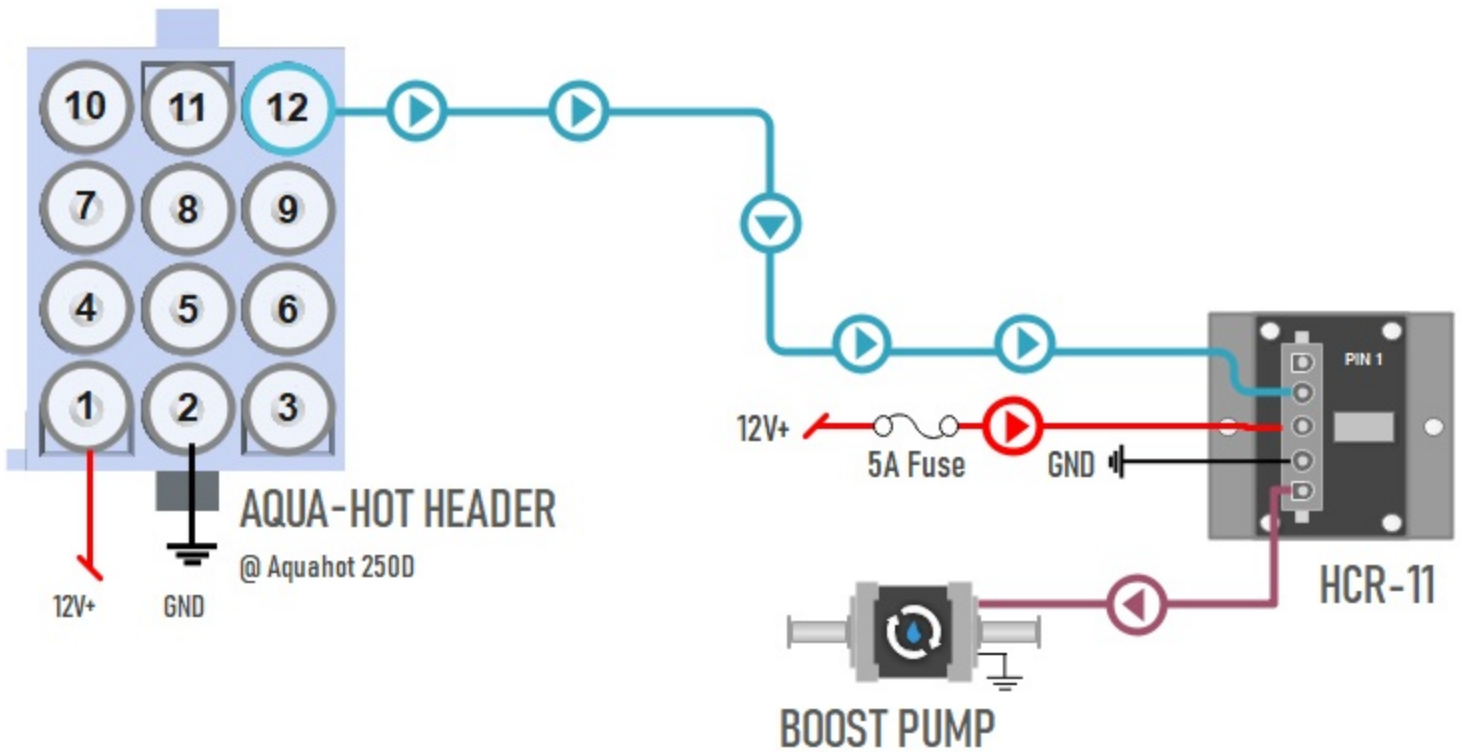

The boost pump is triggered automatically by the AH 250D when an exchanger zone is activated. 12V+ is output from the AH header and passed to the HCR-11.

The HCR-11 uses this as a trigger to provide a higher current output to the boost pump.

- If you **don't** have voltage being emitted from pin 12 on the AH header contact Aqua-Hot
- If you **do** have voltage being emitted from pin 12 on the AH header but you do not have this same voltage on pin 2 of the HCR-11, check the wiring.
- If you **do** have 12V+ on pin 2 of the HCR-11 and you **don't** have 12V+ being output from pin 5 on the HCR-11, check for 12V+ on pin 3 of the HCR-11.
- If you **don't** have 12V+ on pin 3 of the HCR-11, check the 5A fuse in line to the HCR-11.
- If the fuse is OK, check the grounding on pin 4 of the HCR-11
- If all of the above has been checked and you still do not have power going to the boost pump contact Spyder.