



# Multiplex Integration Schematic

---

## 2022 Allegro Open Road

32 SA 34 PA 36 LA 36 UA

**SPYDER**  
CONTROLS CORP









# Table of Contents

! COMPONENTS ARE NOT TO SCALE !

1	Module Locations
2	G6 House Pinout
3	G6 Chassis Pinout
4	Lighting
5	Slides
6	Vent Fans
7	Tank Sensing
8	HVAC

9	Water Heat / Pump
10	Batt. Merge System
11	Critical Network
12	Misc.
13	Network Connectors

Schematic Connections Legend

	Constant Ground
	Constant 12V+
	Switched Ground
	Switched 12V+
	Reverse Polarity
	Signal
	120V AC Line
	Network

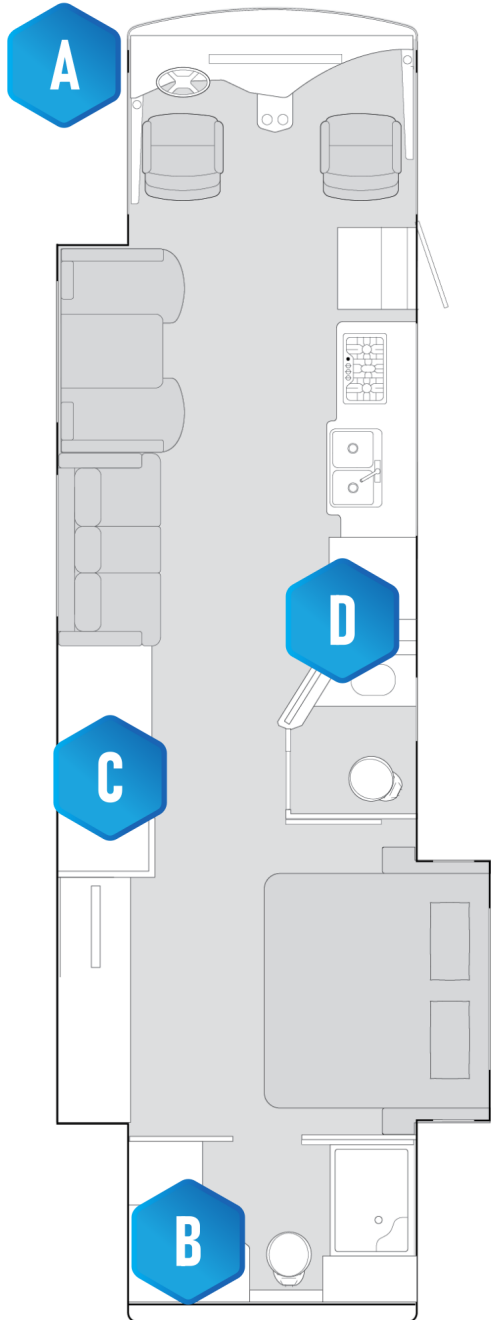

**A** G6 CHS PANEL

**i**  
 Spyder Part Number  
 BENCZ54DI  
 Tiffin Part Number  
 5113996  
 Dimensions  
 10" X 10"

NET PORT      NET LED

**B** G6 HSE PANEL

**i**  
 Spyder Part Number  
 BENCZ52DI  
 Tiffin Part Number  
 5114032  
 Dimensions  
 10" X 10"

NET PORT      NET LED

**C** DCD Panel

**i**  
 Spyder Part Number  
 BENCZ38DI  
 Tiffin Part Number  
 5114015  
 Dimensions  
 10" X 4"

TIFFIN MOTORHOMES

**D** 7" Lite Color LCD

**i**  
 Spyder Part Number  
 BSSPZZQDU  
 Tiffin Part Number  
 5114024  
 Dimensions  
 7.6" X 5"

**G6A CONTROL PANEL LAYOUT**  
 Tiffin PN: 5114032 Spyder PN: BENCZ52DI  
 2022 Allegro - HOUSE Rev 0vA  
**PINOUT DIAGRAM - 2021-01-06**

**Back View**

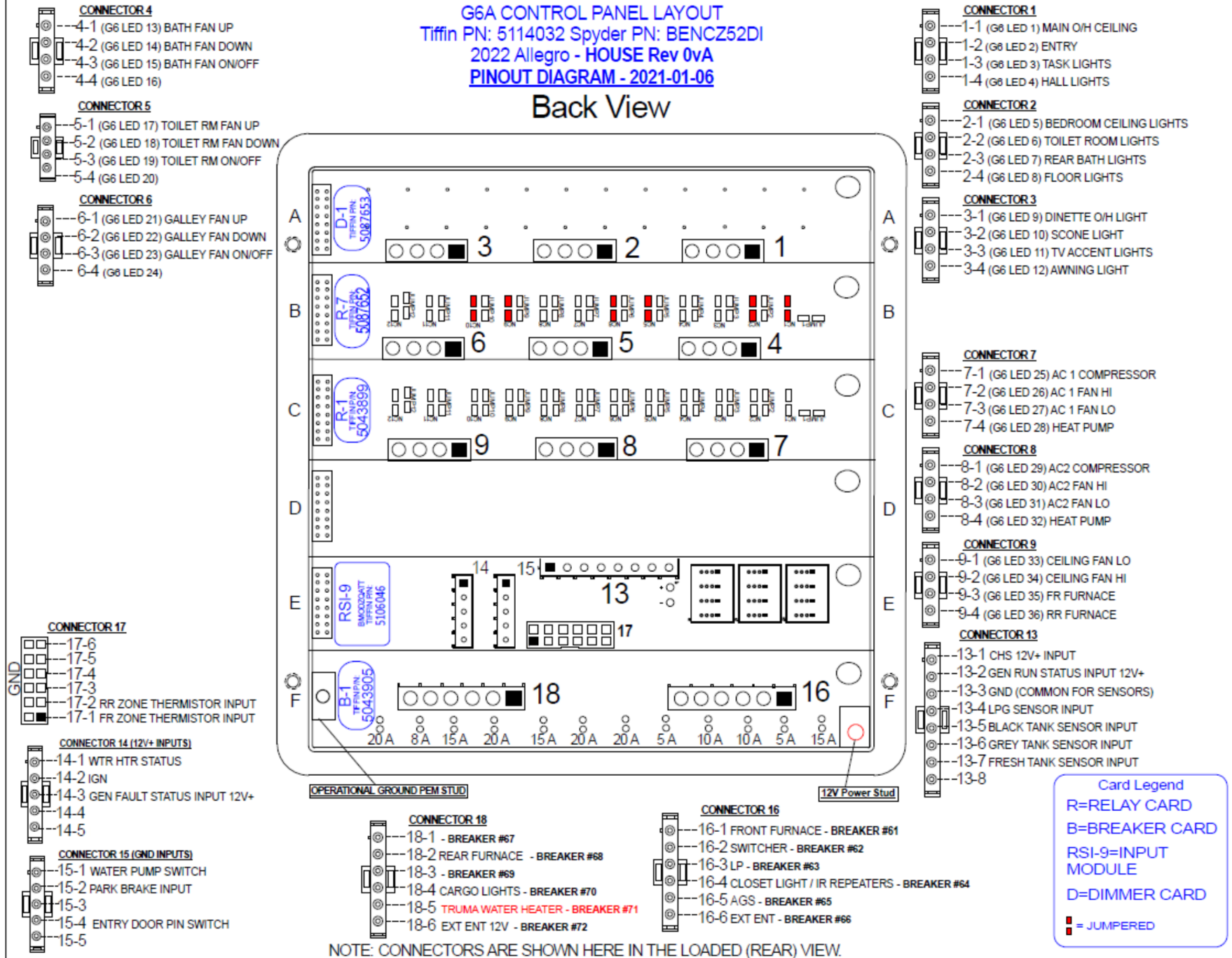

G6A CONTROL PANEL LAYOUT  
 Tiffin PN: 5113996 Spyder PN: BENCZ54DI  
 Allegro - CHASSIS Rev 0va  
 PINOUT DIAGRAM - 02.04.2021

Back View

Driver Card BMODWY6PC - 60 to 120 dimmer mode

- CONNECTOR 4**
- 4-1 (G6 LED 13) WATER PUMP
  - 4-2 (G6 LED 14) PORCH LIGHT
  - 4-3 (G6 LED 15) WATER HEATER ELEC
  - 4-4 (G6 LED 16) WATER HEATER GAS
- CONNECTOR 5**
- 5-1 (G6 LED 17)
  - 5-2 (G6 LED 18)
  - 5-3 (G6 LED 19) GALLEY NIGHT SHADE UP
  - 5-4 (G6 LED 20) GALLEY NIGHT SHADE DN
- CONNECTOR 6**
- 6-1 (G6 LED 21)
  - 6-2 (G6 LED 22)
  - 6-3 (G6 LED 23)
  - 6-4 (G6 LED 24)
- CONNECTOR 13**
- 13-1 MAP LT / RADIO / FANS - BREAKER #49
  - 13-2 USB POWER - BREAKER #50
  - 13-3 WIPER HIGH RELAY - BREAKER #51
  - 13-4 ENTRY STEP SWITCH - BREAKER #52
  - 13-5 ENTRY STEP POWER - BREAKER #53
  - 13-6 WINDOW - BREAKER #54
- CONNECTOR 15**
- 15-1 POWER SEAT #1 - BREAKER #55
  - 15-2 A/C FAN - BREAKER #56
  - 15-3 HOOD LIGHTS - BREAKER #57
  - 15-4 TRAILER 12V POWER - BREAKER #58
  - 15-5 SHADES - BREAKER #59
  - 15-6 POWER SEAT #2 - BREAKER #60

**Card Legend**

- R=RELAY CARD
- B=BREAKER CARD
- BR=BREAKER/RELAY CARD
- D=DIMMER CARD
- = JUMPERED

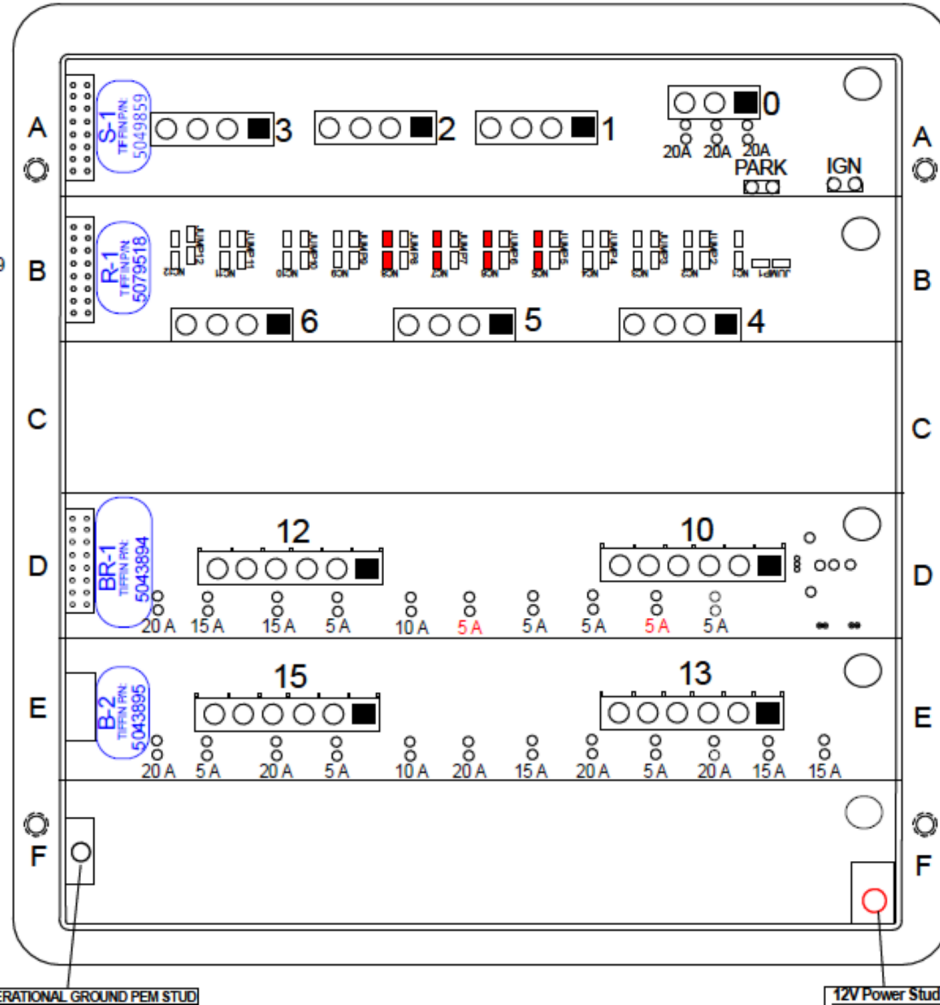

- CONNECTOR 0**
- 0-1 FRONT SLIDE MODULE
  - 0-2 VANITY SLIDE MODULE
  - 0-3 BED SLIDE MODULE
- CONNECTOR 1**
- 1-1 (G6 LED 1) D/S FR SLIDE RET
  - 1-2 (G6 LED 2) D/S FR SLIDE EXT
  - 1-3 (G6 LED 3) P/S FR SLIDE RET
  - 1-4 (G6 LED 4) P/S FR SLIDE EXT
- CONNECTOR 2**
- 2-1 (G6 LED 5) D/S RR SLIDE RET
  - 2-2 (G6 LED 6) D/S RR SLIDE EXT
  - 2-3 (G6 LED 7) P/S RR SLIDE RET
  - 2-4 (G6 LED 8) P/S RR SLIDE EXT
- CONNECTOR 3**
- 3-1 (G6 LED 9) D/S HYDRAULIC PUMP
  - 3-2 (G6 LED 10) P/S HYDRAULIC PUMP
  - 3-3 (G6 LED 11) DOOR
  - 3-4 (G6 LED 12)
- CONNECTOR 10**
- 10-1 - BREAKER #37
  - 10-2 - BREAKER #38
  - 10-3 FRIDGE / TV RELAY - BREAKER #39
  - 10-4 DRIVERS MIRROR PWR - BREAKER #40
  - 10-5 CAMERA IGN - BREAKER #41
  - 10-6 JACK BUZZER - BREAKER #42
- CONNECTOR 12**
- 12-1 PASS SIDE MIRROR PWR - BREAKER #43
  - 12-2 - BREAKER #44
  - 12-3 ENTRY STEP IGN - BREAKER #45
  - 12-4 - BREAKER #46
  - 12-5 - BREAKER #47
  - 12-6 POWER WINDOW OPTION - BREAKER #48

OPERATIONAL GROUND PEM STUD

12V Power Stud

NOTE: CONNECTORS ARE SHOWN HERE IN THE LOADED (REAR) VIEW.

# CON 3

Dimming Lights

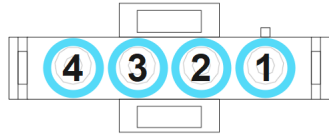

1 G6 LED 9 - Dinette O/H Lts

3 G6 LED 11 - TV Accent Lts

2 G6 LED 10 - Sconce Lts

4 G6 LED 12 - Awning Lts

# CON 2

Dimming Lights

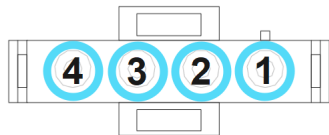

1 G6 LED 5 - Bedroom Ceiling Lts

3 G6 LED 7 - Rear Bath Lts

2 G6 LED 6 - Toilet Room Lts

4 G6 LED 8 - Floor Lts

# CON 1

Dimming Lights

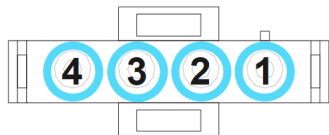

1 G6 LED 1 - Main O/H Ceiling Lts

3 G6 LED 3 - Task Lts

2 G6 LED 2 - Entry Lts

4 G6 LED 4 - Hall Lts

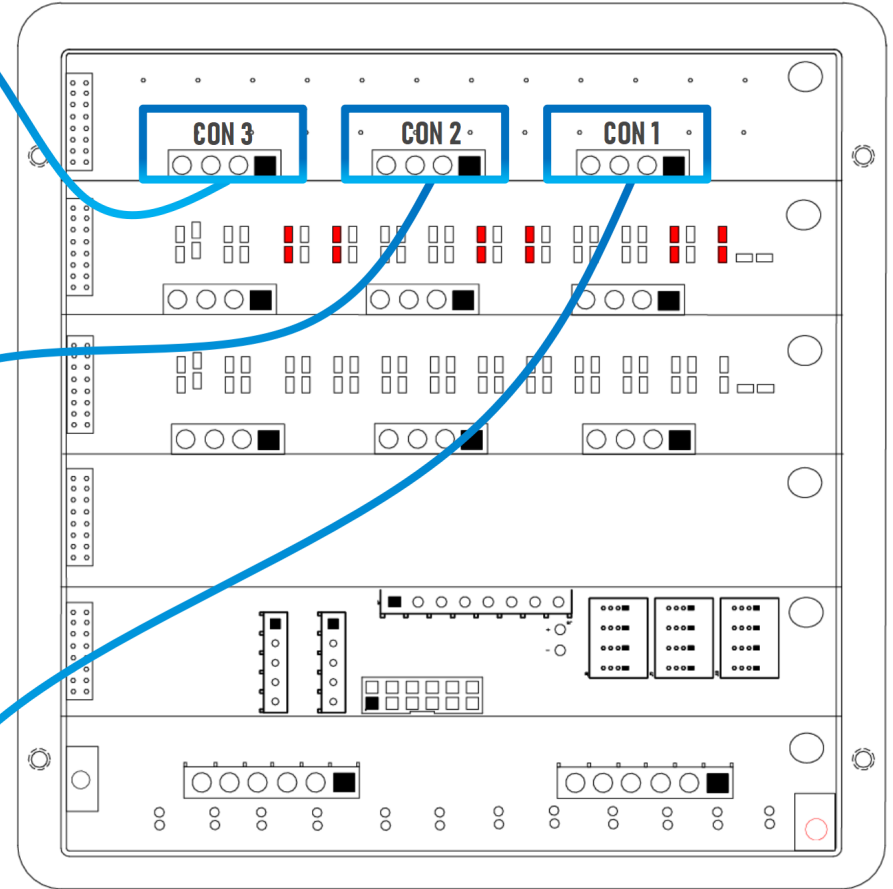

## G6 HOUSE PANEL

@ Bathroom Vanity

### Front Slide Outputs

- Power Input
- D/S Front Slide Retract
- D/S Front Slide Extend
- P/S Front Slide Retract
- P/S Front Slide Extend

### Hydraulic Pumps

- Hydraulic Pump
- Power Input

### Rear Slide Outputs

- Power Input
- P/S Rear Slide Extend
- P/S Rear Slide Retract
- D/S Rear Slide Extend
- D/S Rear Slide Retract

### Emergency Override

Park brake and ignition must be on for slides to operate.  
 In case of a system failure, use manual overrides on front of G6 Chassis panel to operate slides. Engage overrides using a pen or other pointed object.

### G6 CHASSIS PANEL

@ EXT D/S Comp

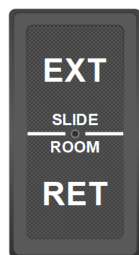

**D/S Front Slide Switch**

@ D/S Seat



**P/S Front Slide Switch**

@ P/S Seat

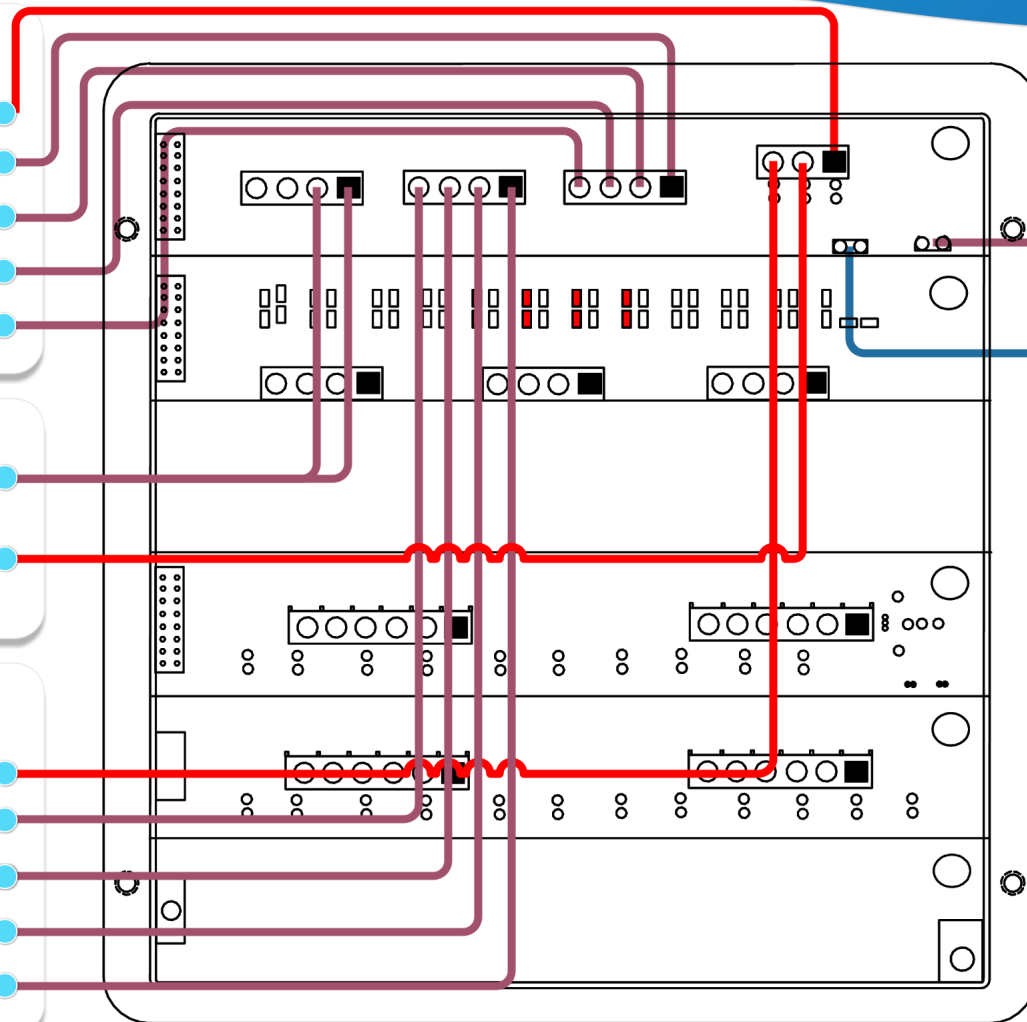

Ignition Switch

Park Brake Switch

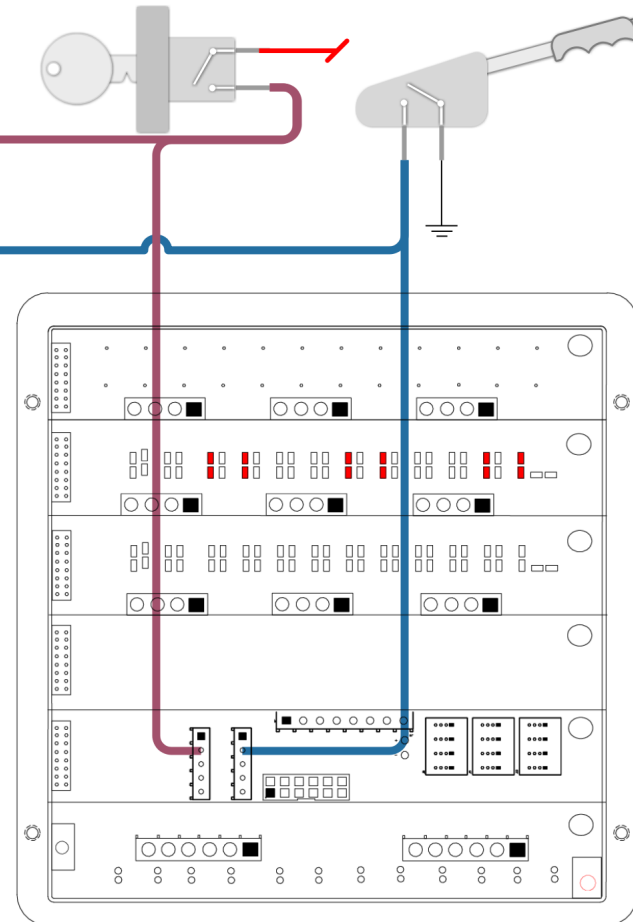

### G6 HOUSE PANEL

@ Bathroom Vanity

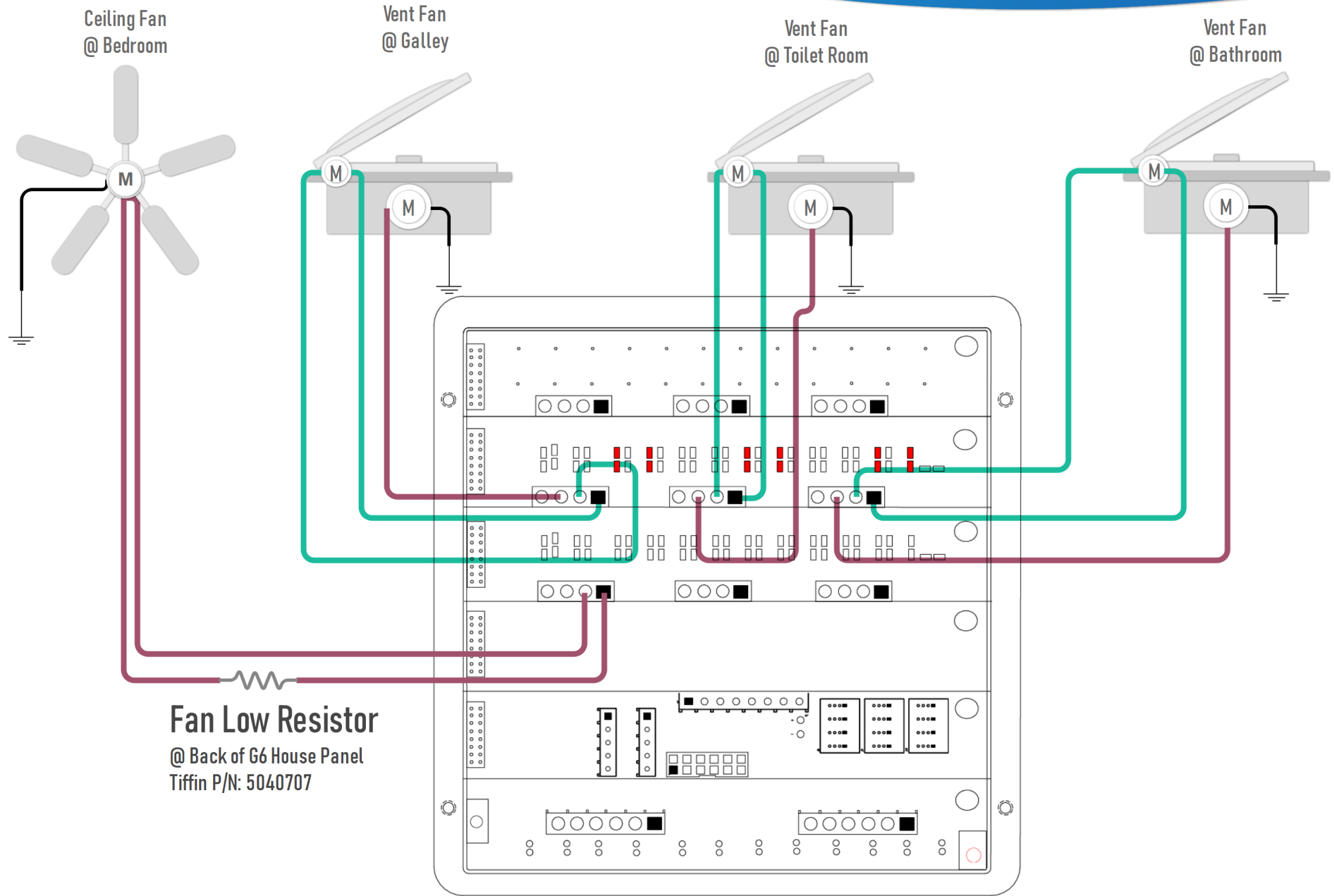

Ceiling Fan @ Bedroom

Vent Fan @ Galley

Vent Fan @ Toilet Room

Vent Fan @ Bathroom

**Fan Low Resistor**  
@ Back of G6 House Panel  
Tiffin P/N: 5040707

**G6 HOUSE PANEL**  
@ Bathroom Vanity

# CON 13

## 3 Level Tank Sensor System

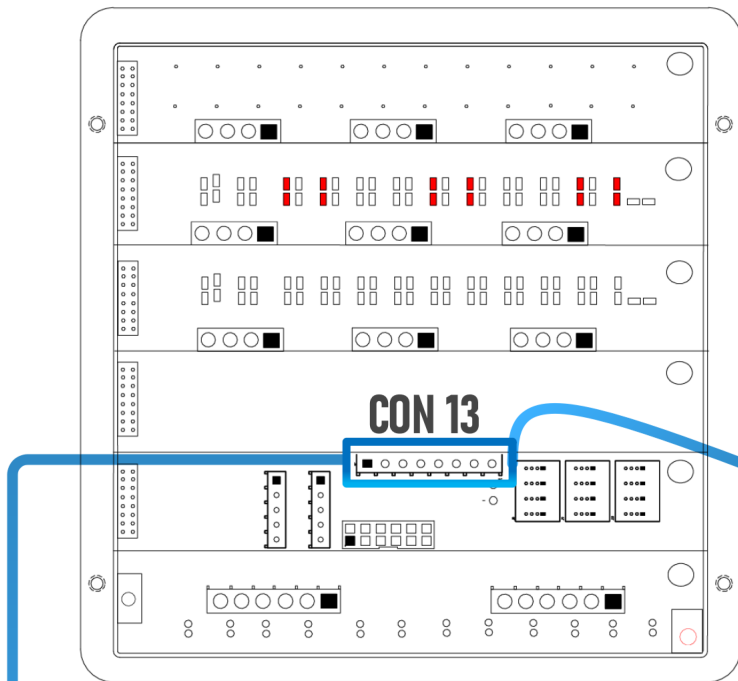

### G6 HOUSE PANEL

@ Bathroom Vanity

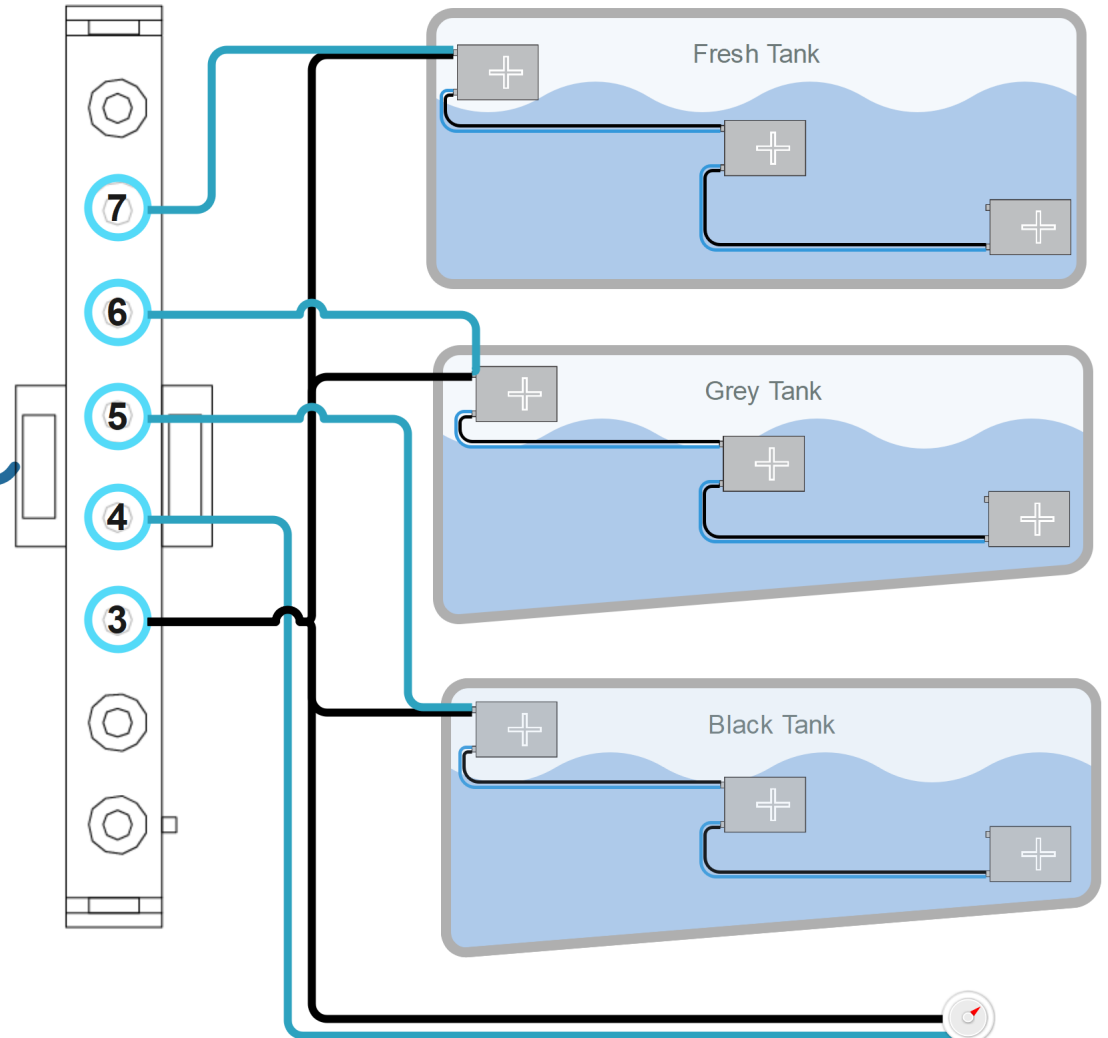

# CON 13

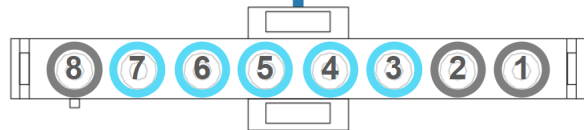

- 3 Common Ground
- 4 LPG Sensor Input
- 5 Black Sensor Input
- 6 Grey Sensor Input
- 7 Fresh Sensor Input

# G6 HOUSE PANEL

@ Bathroom Vanity

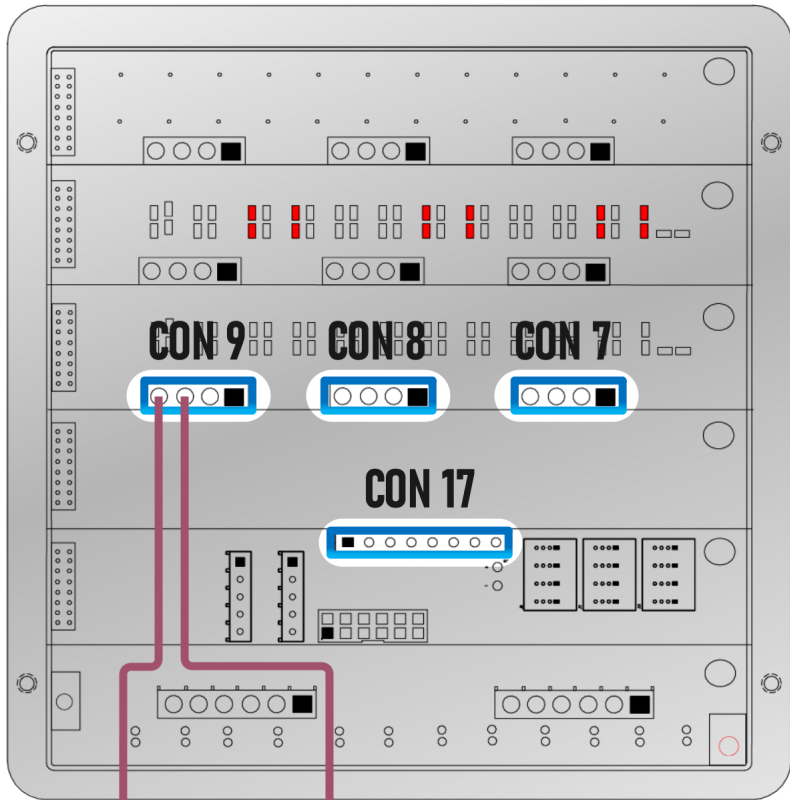

Rear Furnace



Front Furnace

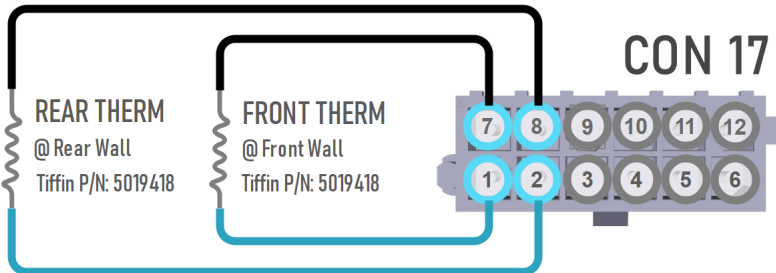

## REAR AC

@ Roof

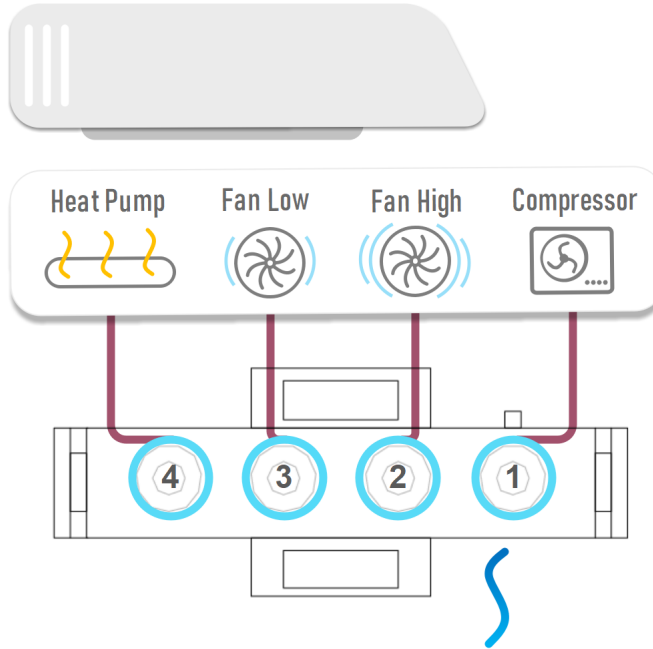

### CON 8

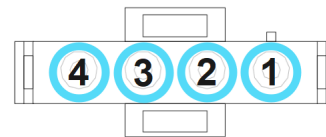

- 1 G6 LED 29 - Rear A/C Compressor
- 2 G6 LED 30 - Rear A/C Fan High
- 3 G6 LED 31 - Rear A/C Fan Low
- 4 G6 LED 32 - Rear A/C Heat Pump

## FRONT AC

@ Roof

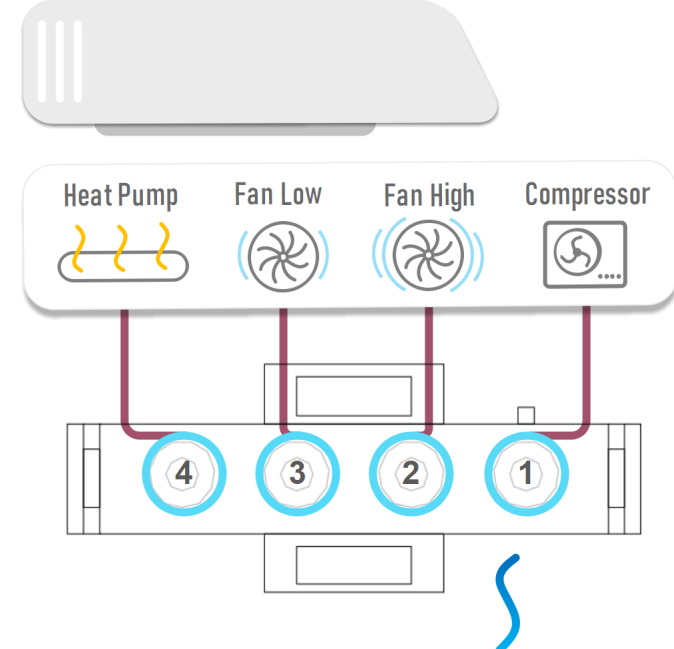

### CON 7

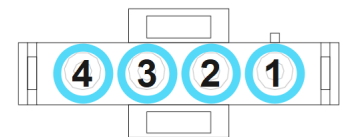

- 1 G6 LED 25 - Front A/C Compressor
- 2 G6 LED 26 - Front A/C Fan High
- 3 G6 LED 27 - Front A/C Fan Low
- 4 G6 LED 28 - Front A/C Heat Pump

HVAC thermistors - 100K ohms @ 25 C or 77 F

NOTE: As the temperature increases the resistance lowers

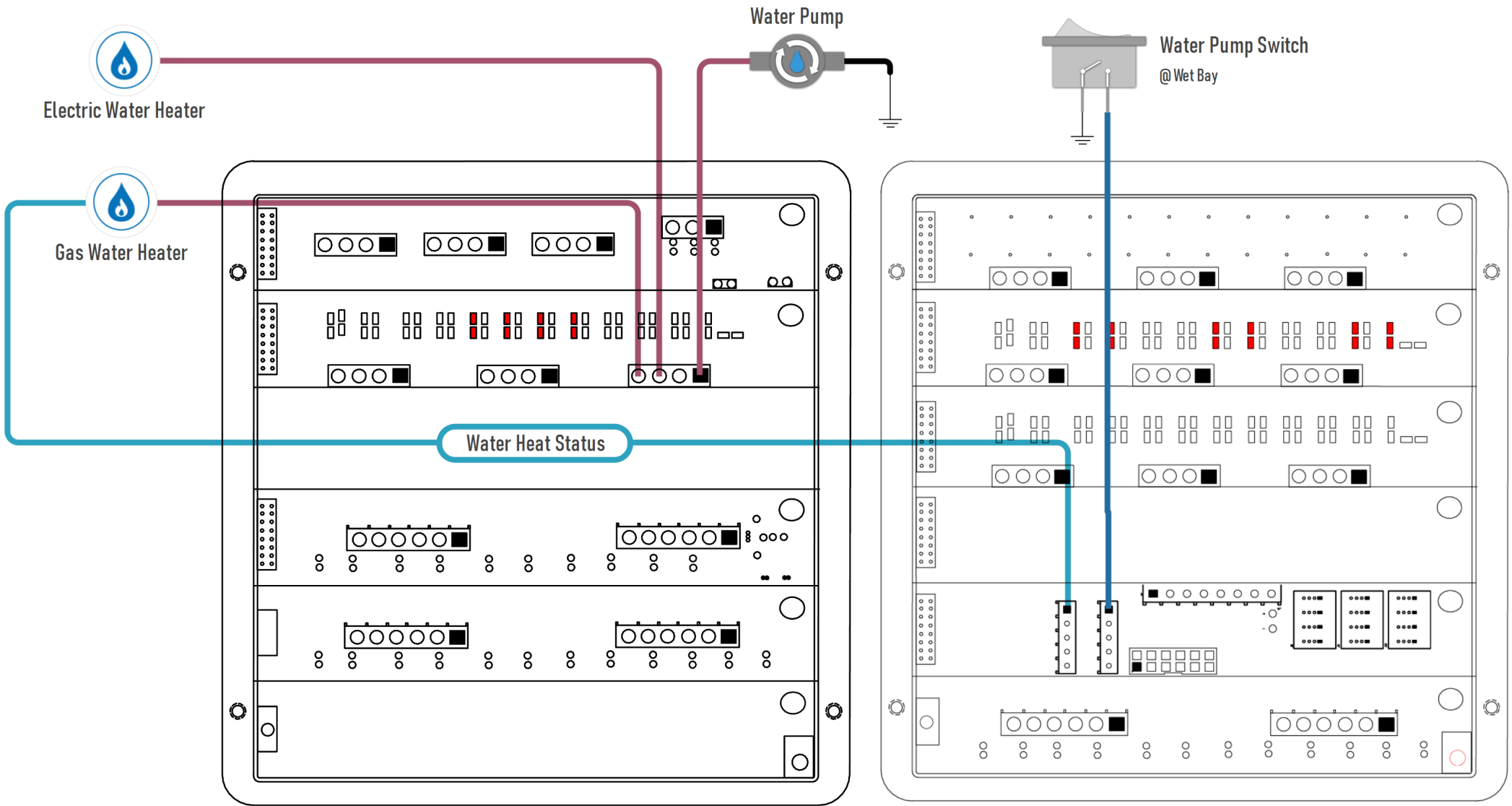

## NOTE

Please note that the Spyder system in the 2022 Allegro Open Road in no way decides when the batteries should merge. Any auto merge functionality comes from a non-Spyder source in the coach. The BDC2 only receives inputs and in direct response outputs 12V+ to the Merge Solenoid.

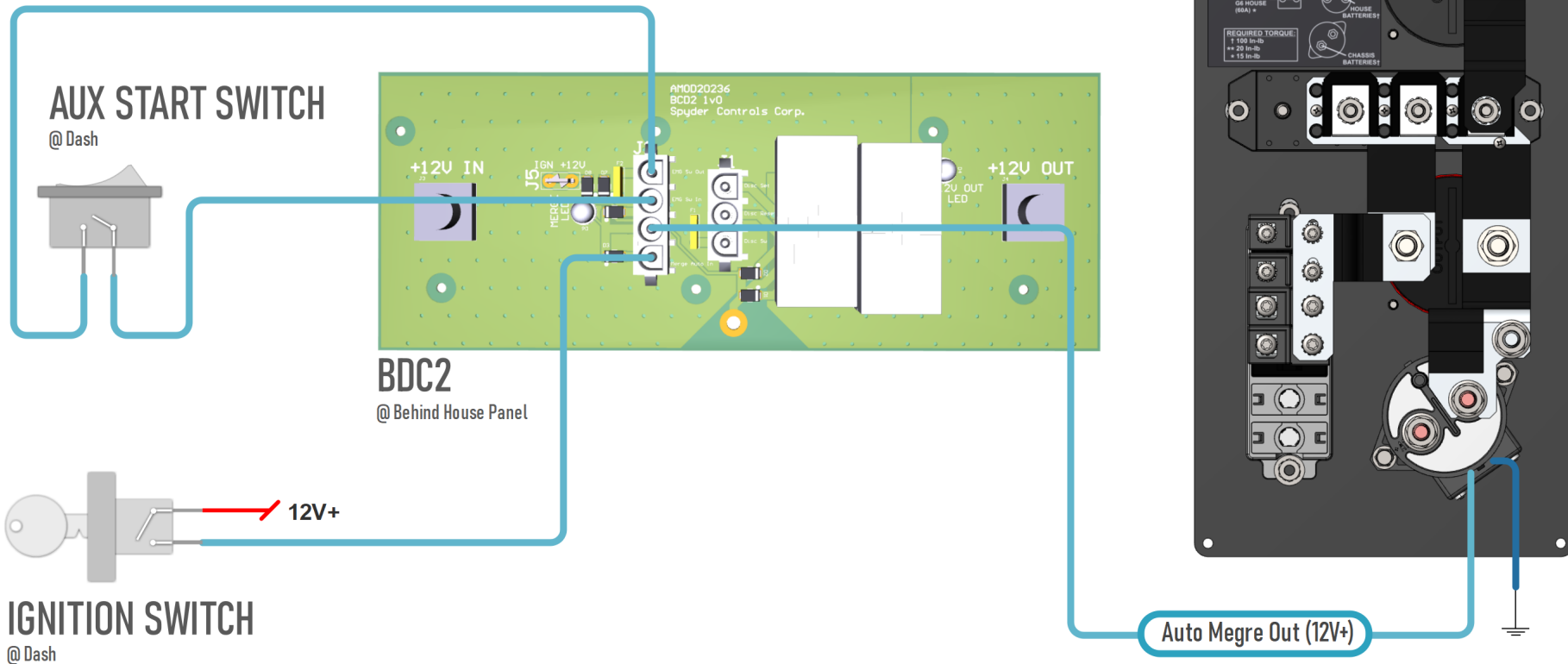

### NOTE

Not all Spyder devices connected via RV-C are displayed here. This diagram displays the modules that are critical for normal operation. Modules labelled "TERMINATOR" must always be present in the network for proper network health.

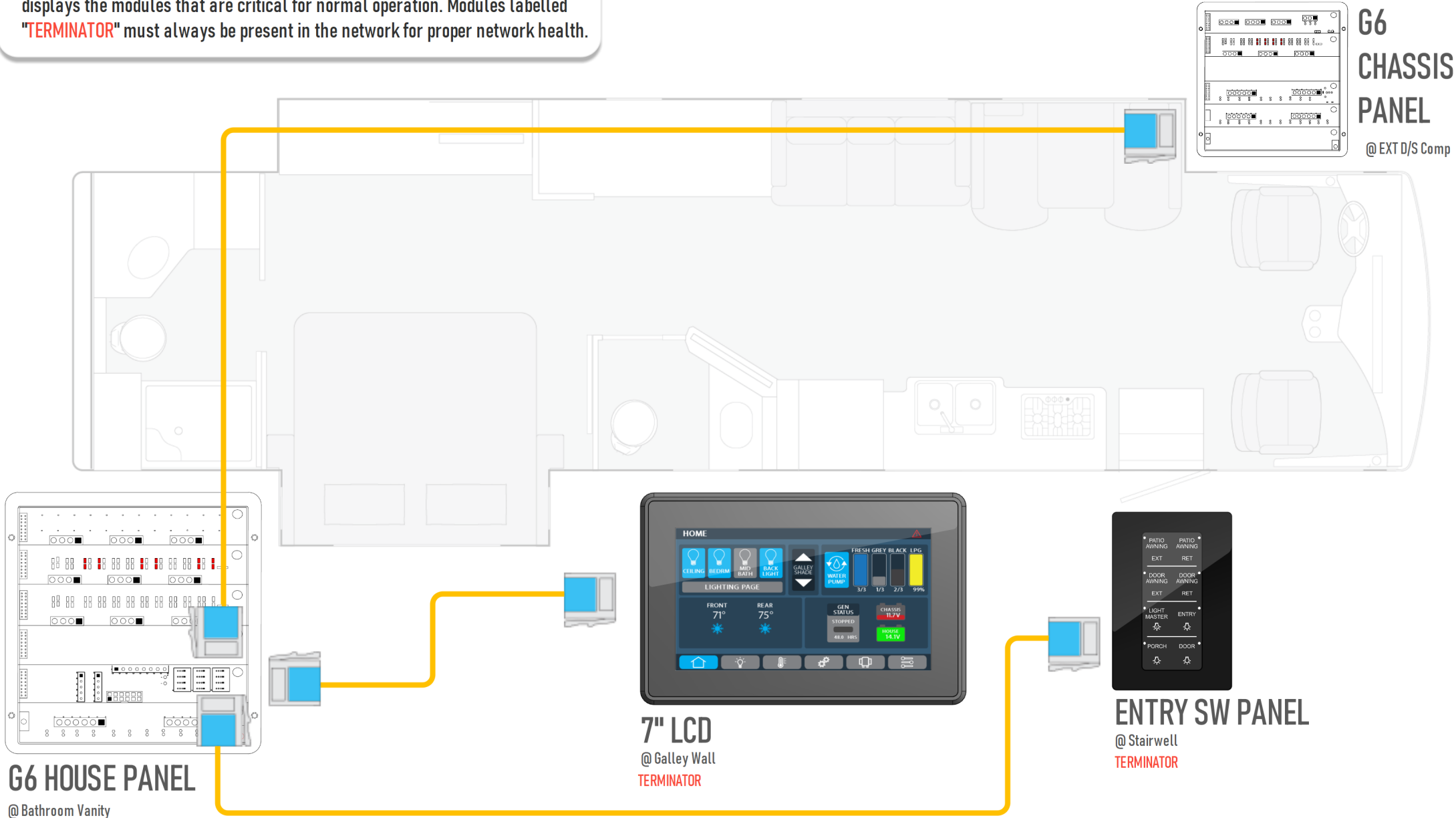

**G6 HOUSE PANEL**  
@ Bathroom Vanity

**7" LCD**  
@ Galley Wall  
**TERMINATOR**

**ENTRY SW PANEL**  
@ Stairwell  
**TERMINATOR**

**G6 CHASSIS PANEL**  
@ EXT D/S Comp

# G6 HOUSE PANEL

@ Bathroom Vanity

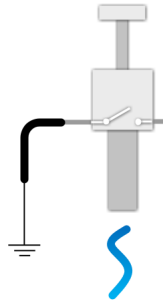
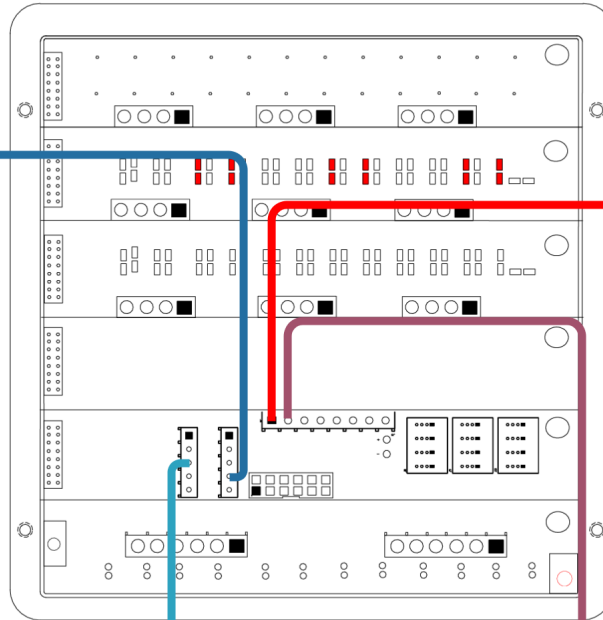

## Entry Door Pin Switch

When the door is opened, the Entry Light turns on for 2 minutes and panel lights on the Entry switch panel turn on.

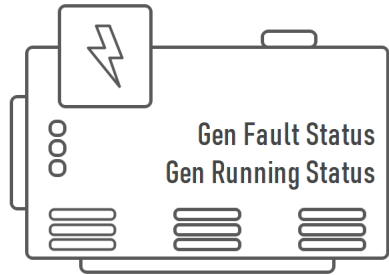

## CHASSIS VOLTAGE SENSE

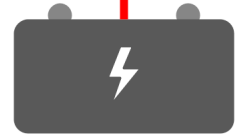

CHASSIS BATTERY

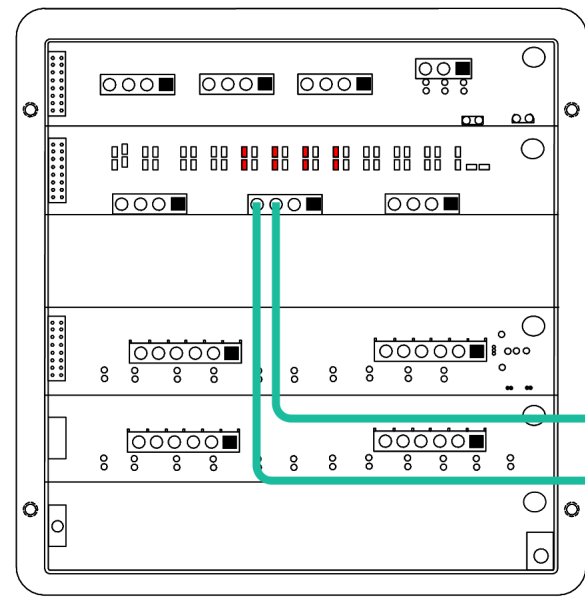

Galley Night Shade



# G6 CHASSIS PANEL

@ EXT D/S Comp

G3 Terminator Tap  
Tiffin P/N: 5051935

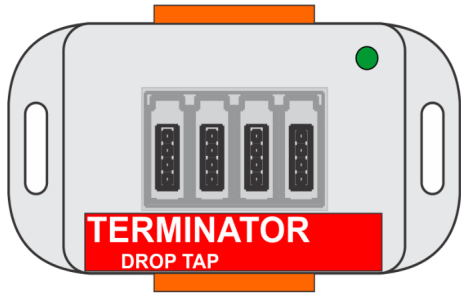

G3 Common Tap  
Tiffin P/N: 5027834

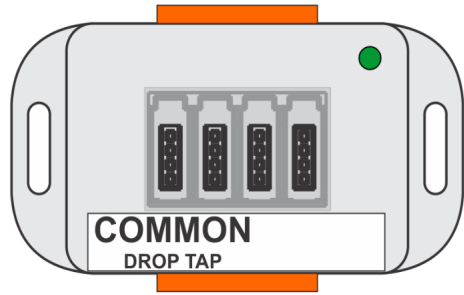

G4 Common Drop Tap  
Tiffin P/N: 5016592

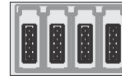

Mini-Clamp Plug  
Tiffin P/N: 5066157  
3M P/N: 37104-2165-000 FL 100



G4 Terminator Drop Tap  
Tiffin P/N: 5051936



Mini-Clamp Socket  
Tiffin P/N: 5066158  
3M P/N: 37304-2165-000 FL 100



4 Pos Wago Connector  
Tiffin P/N: 5015508

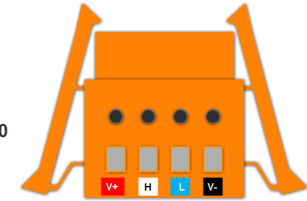

Wago Hook Tool  
Wago P/N: 231-131

