

# 2027 Tiffin Phaeton

## Integration Schematics









---

[www.spydercontrols.com](http://www.spydercontrols.com)



# Table Of Contents

Component Locations	1	HVAC	21
DC Distribution	2	Aircons & Overrides	22
Misc. Modules	3	Thermistors	23
Misc. Modules Cont.	4	Floorheat	24
LCD Screens	5	Vent Fans	25
Dash	6	Power Systems	26
Pinouts	7	Front HCR-11	27
M1 Dash Panel Pinout	8	Merge System	28
M1 Front Panel Pinout	9	Merge Logic	29
M1 Mid Panel Pinout	10	EMS (Energy Management System)	30
M1 Rear Panel Pinout	11	Generator	31
SSP25 Button Layout	12	DCD Panel	32
Mechanical Systems	13	Trustate	33
Slides	14	DCD Panel Cont.	34
Bed Lift	15	Shade Module Power	35
MoRyde TV Lift	16	Network	36
Whisper Ride TV Lift	17	CAN Router	37
Shades	18	Blue Network	38
Motors & Pumps	19	Blue Network Cont.	39
Tanks	20	Yellow Network	40
		Orange Network	41
		Always On	42
		Additional Information	43
		Connectors	44
		Connectors & Tools	45

Connection Legend	
Line Color	Line Meaning
	(GND) Constant Ground
	(12V+) Constant 12V+
	Switched 12V+
	Signal (Arrow Points to Signal Direction)
	(GND) Ground Input (Arrow Points to Input Device)
	(12V+) 12V+ Input (Arrow Points to Input Device)
	Reverse Polarity
	Network/Communication
	120 VAC LINE

# **Component** Locations

# Component Locations

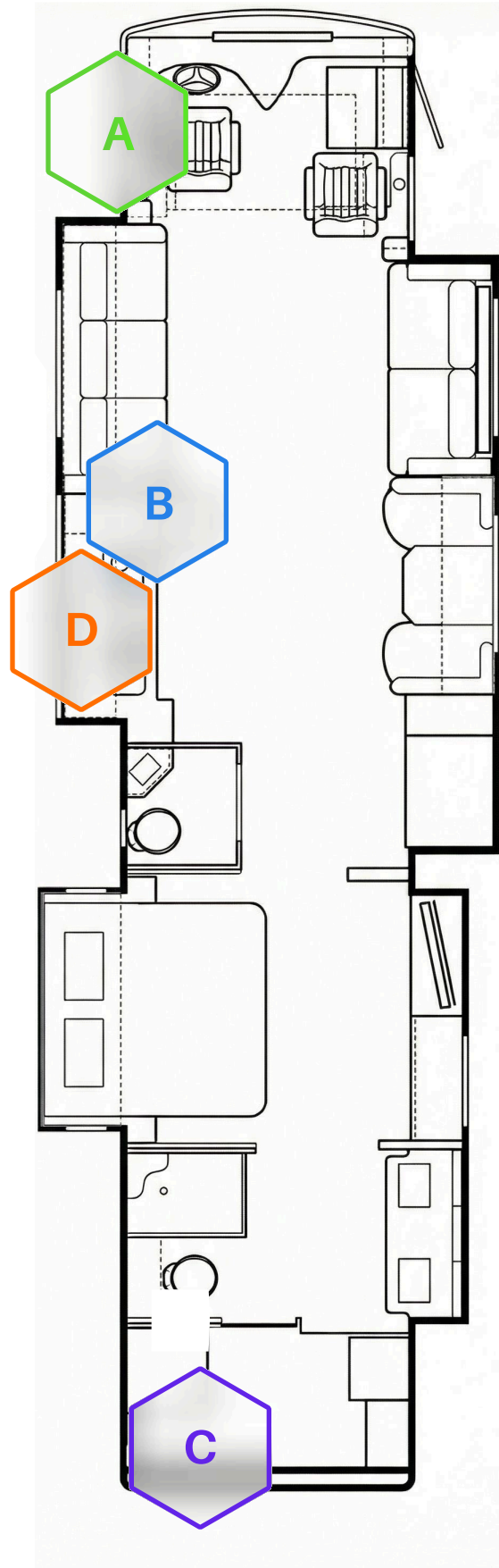

## Front M1 Panel

**Spyder PN**  
BENCZM2DS

**Tiffin PN**  
5126983

**Dimensions**  
10" X 7.8"

## D/S Ext Compartment

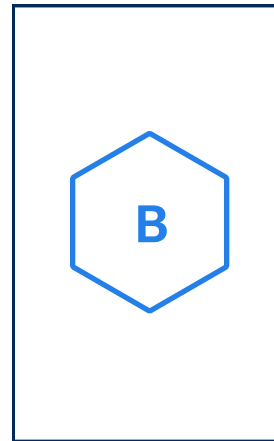
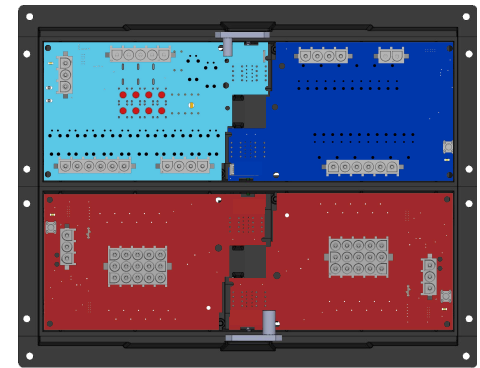

## Mid M1 Panel

**Spyder PN**  
BENCZM4C2

**Tiffin PN**  
5145849

## Inverter Bay

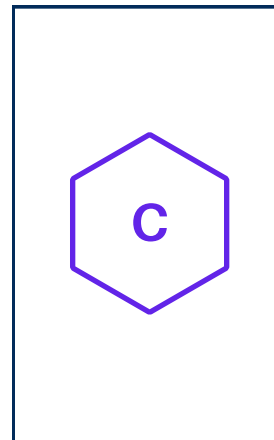
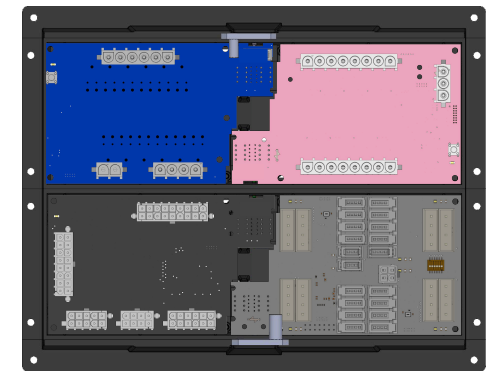

## Rear M1 Panel

**Spyder PN**  
BENCZM6DP

**Tiffin PN**  
5127300

**Dimensions**  
9.1" X 10"

## Rear Closet

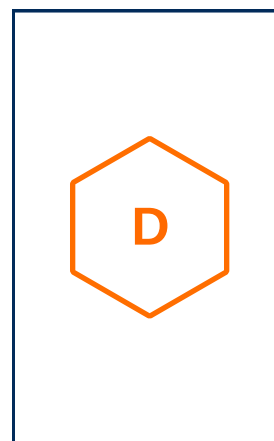
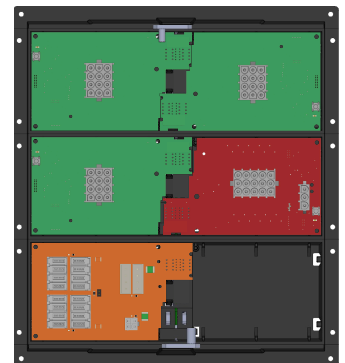

## DCD Panel

**Spyder PN**  
BENCZ38DP-3

**Tiffin PN**  
5181454

**Dimensions**  
13.5" X 12.5"

## Inverter Bay



# Component Locations

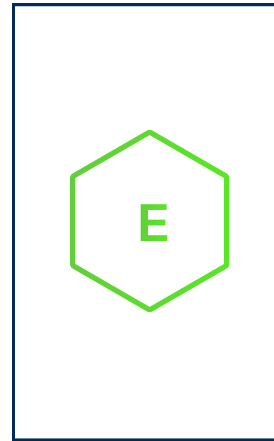
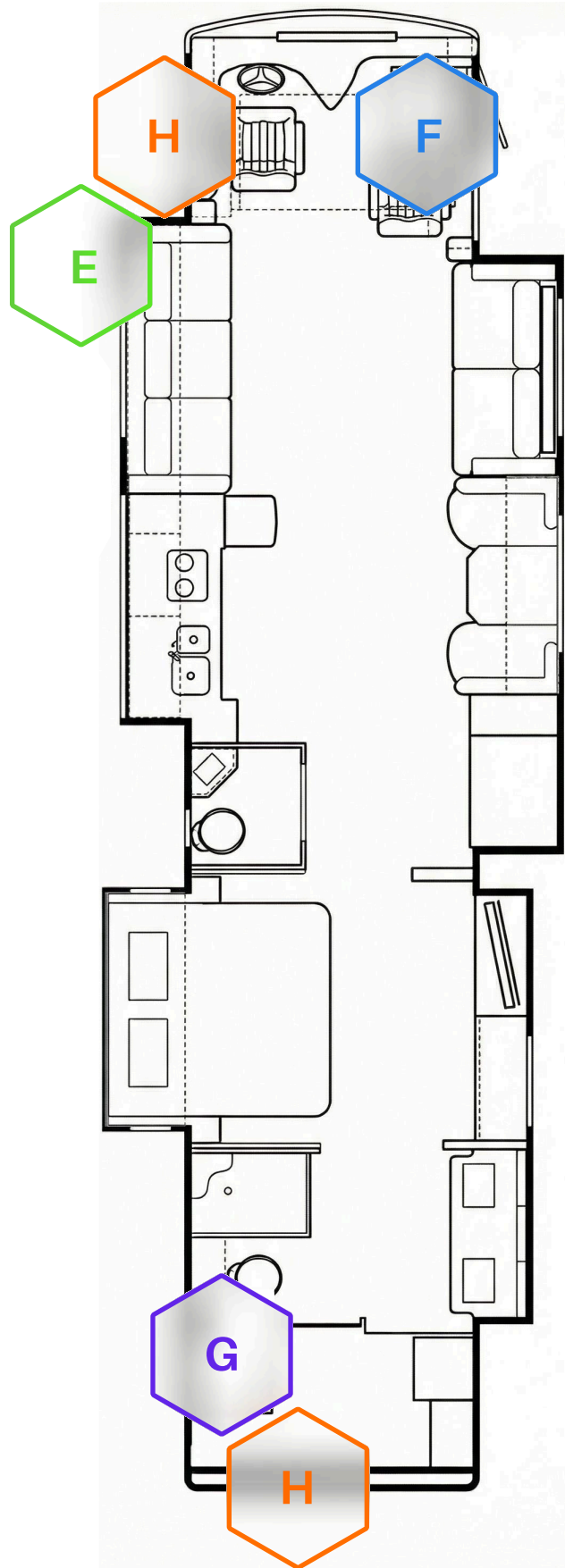

## Terminator HCR-11 Drop

**Spyder PN**  
BMODZGAN6-1

**Tiffin PN**  
5131310

**Dimensions**  
2.5" X 2"

## Front D/S Compartment

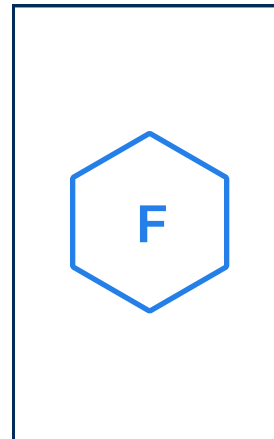
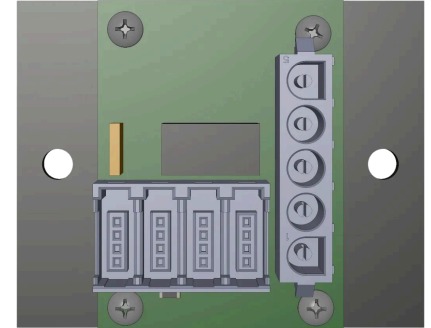

## Mira Module (Not Manufactured By Spyder)

**Tiffin PN**  
5114034

**Dimensions**  
4" X 2.5"

## Front O/H Cabinet

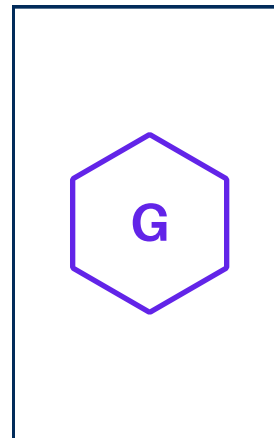

## HCR-15 TV Lift

**Spyder PN**  
BMODZQFCN-A

**Tiffin PN**  
5134953

**Dimensions**  
3" X 3"

## Rear Closet

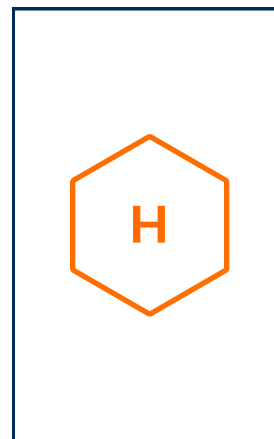
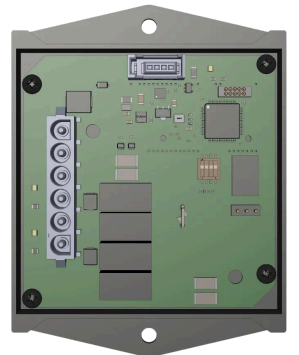

## Bridge Module

**Spyder PN**  
BMODZTCT0

**Tiffin PN**  
5127271

**Dimensions**  
3" X 3"

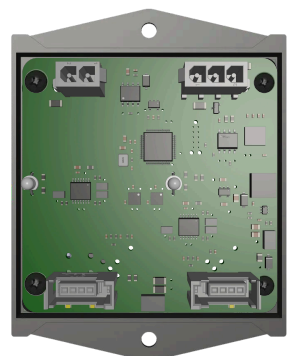

# Component Locations

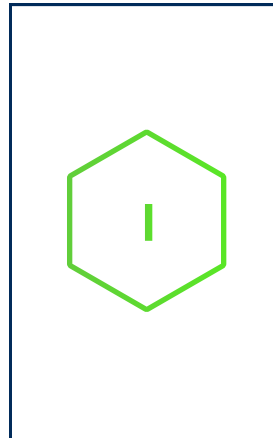
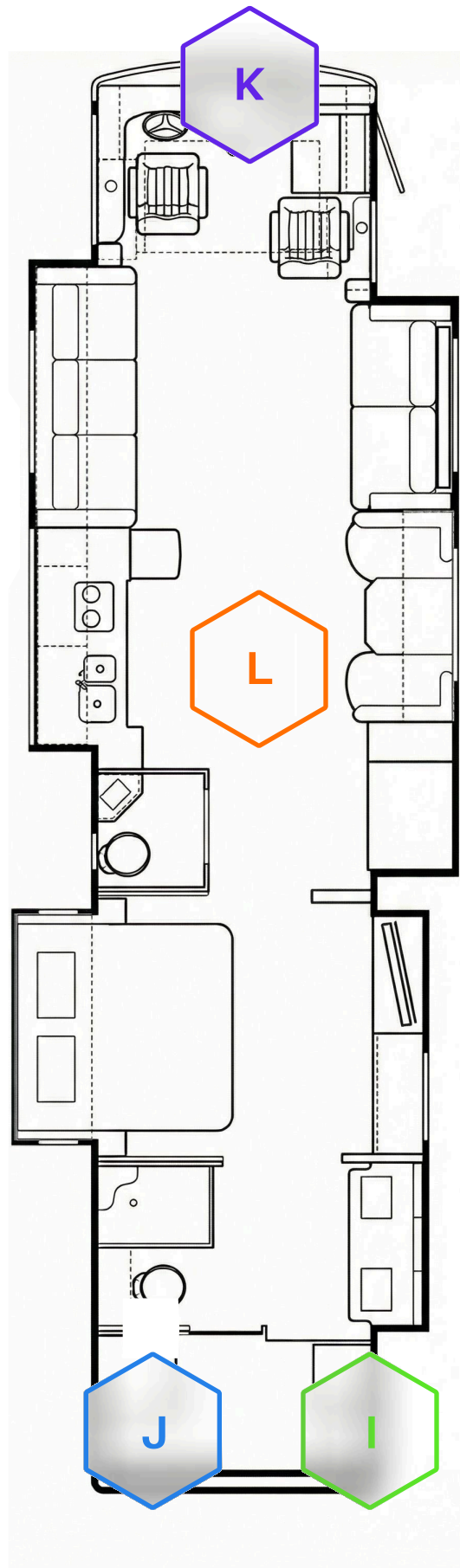

## ACR3

**Spyder PN**  
BMODZYACG-B

**Tiffin PN**  
5091114

**Dimensions**  
6" X 4.8"

## Hall Wall

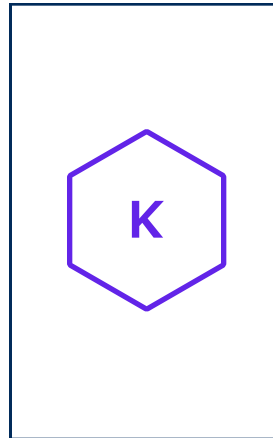
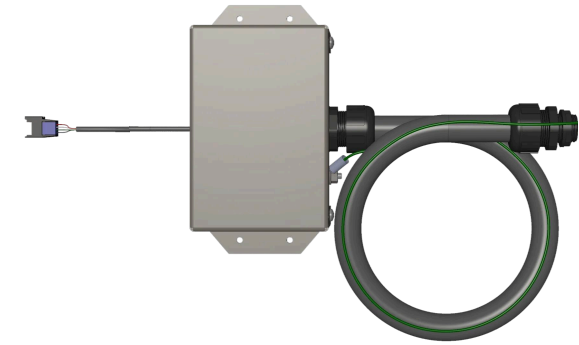

## Shade Module

**Spyder PN**  
BMODZMKM1-T

**Tiffin PN**  
5127302

**Dimensions**  
3.5" X 6.5"

## Rear Closet

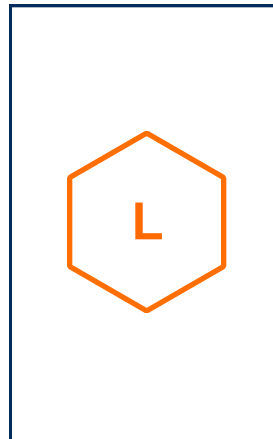
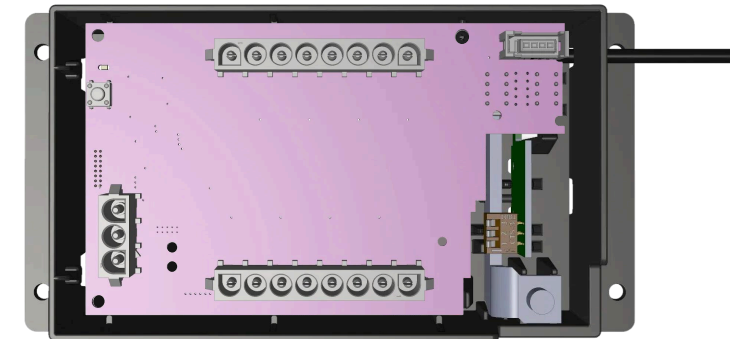

## RF Hub

**Spyder PN**  
BMODZRFT0-W

**Tiffin PN**  
5141264

**Dimensions**  
5.1" Diameter

## Rear Closet



# Component Locations

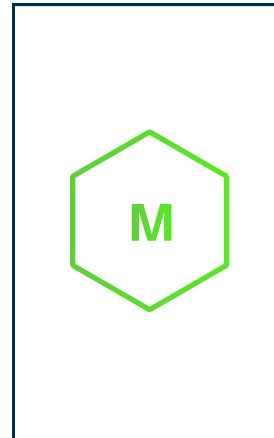
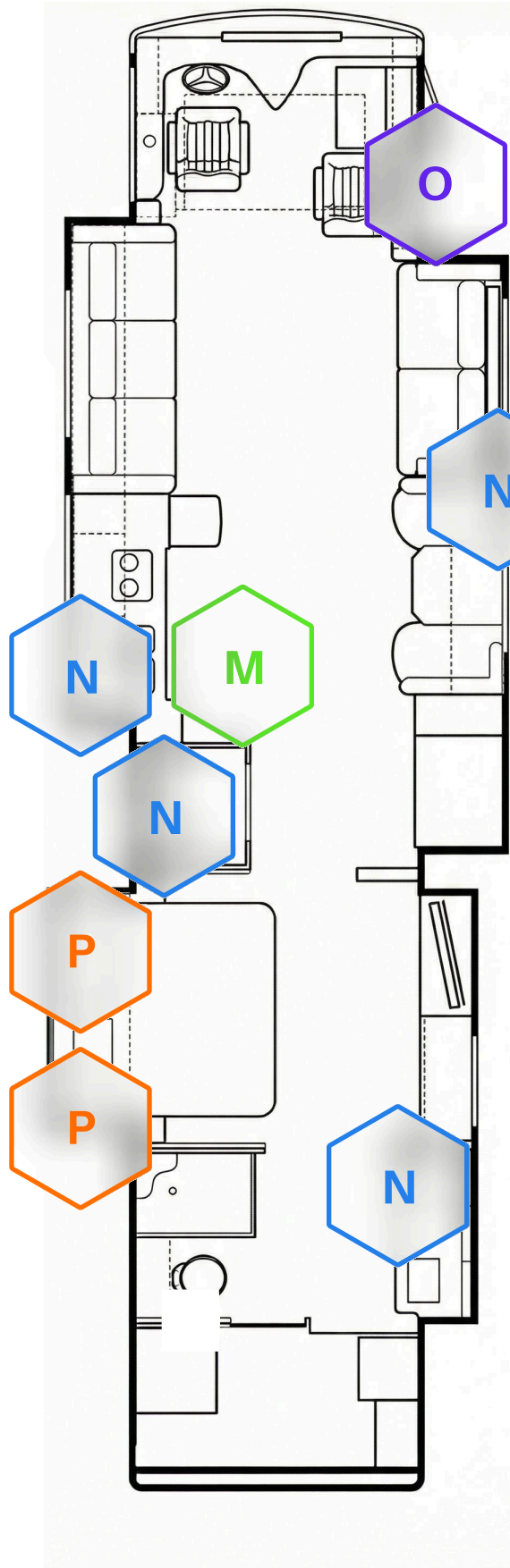

## 10" LCD

**Spyder PN**  
BSSPZZXEF-1  
**Tiffin PN**  
5127306  
**Dimensions**  
10.5" X 7.3"

## Hall Wall

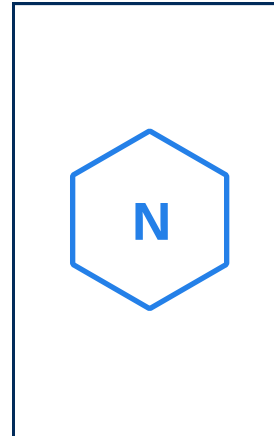

## 3.5" LCD

**Spyder PN**  
BSSPZZTED-1  
**Tiffin PN**  
5133664  
**Dimensions**  
4.5" X 2.9"

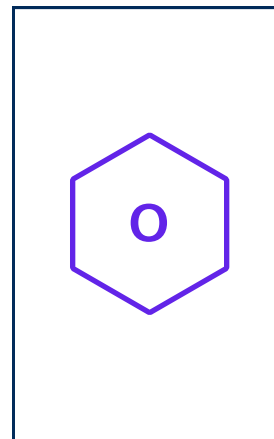
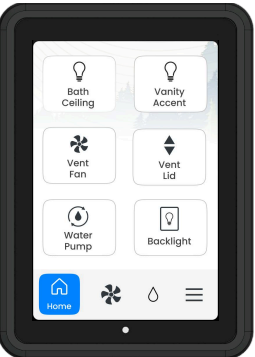

## 5" Exterior LCD

**Spyder PN**  
BSSPZZZEN  
**Tiffin PN**  
5145817  
**Dimensions**  
5.5" X 3.8"

## Entry Exterior

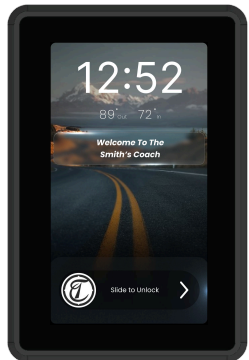

## 5" Bedside LCD

**Spyder PN**  
BSSPZZREK  
**Tiffin PN**  
5127269  
**Dimensions**  
5.5" X 3.8"

## Bedside

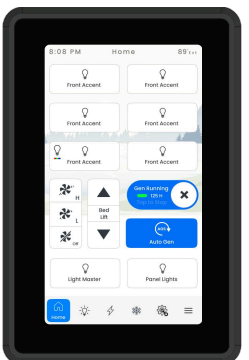

# Component Locations

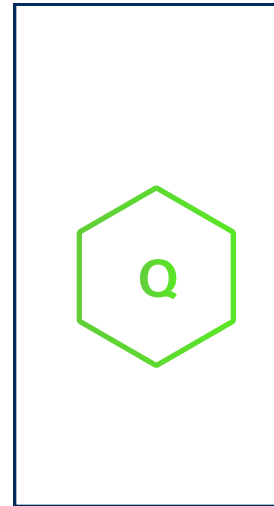
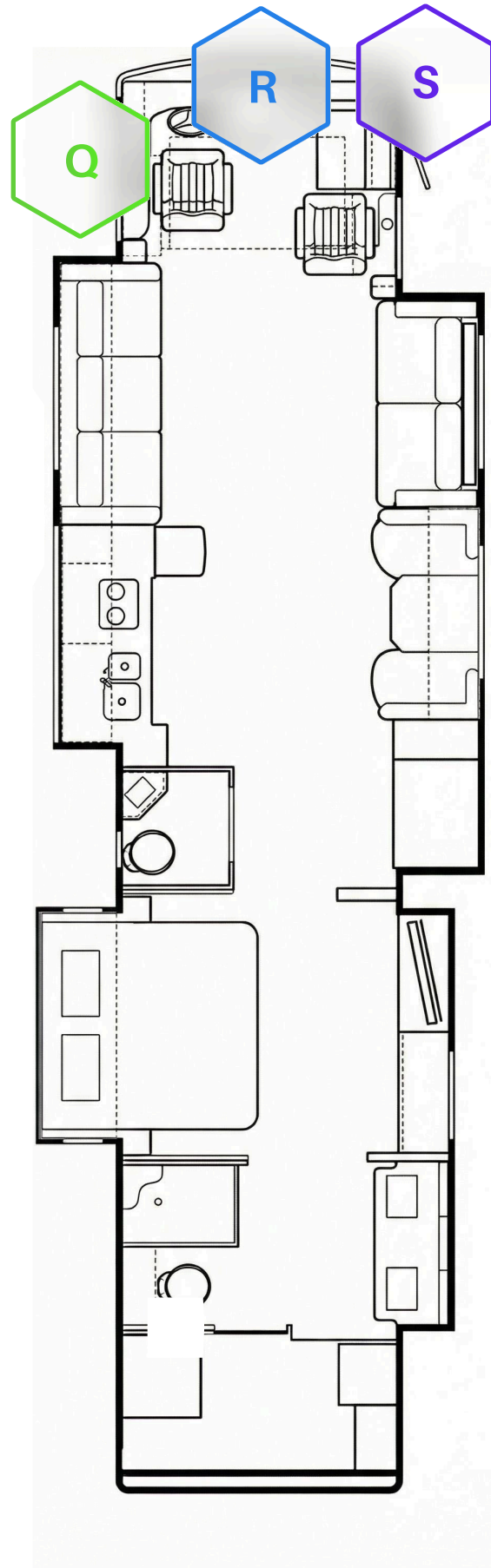

## 2 X 3 Button SSP25

D/S Dash

### Spyder PN

1. BASPZ523HDT0-1A

### Tiffin PN

1. 5169653

### Dimensions

3.6" X 2.8"

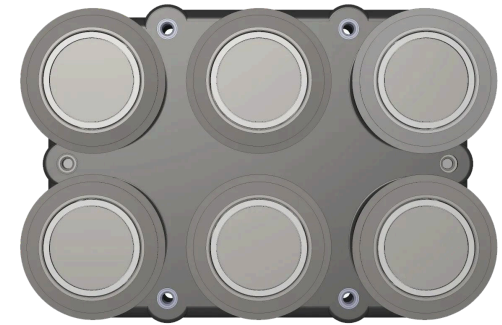

## 2 X 6 Button SSP25

Dash Center

### Spyder PN

BASPZ526HDT0-1A

### Tiffin PN

5169651

### Dimensions

7.3" X 2.8"

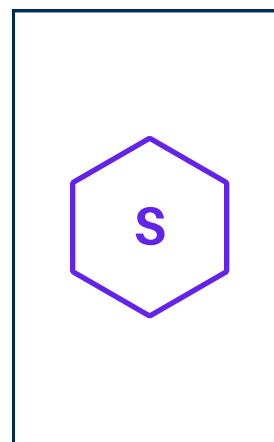
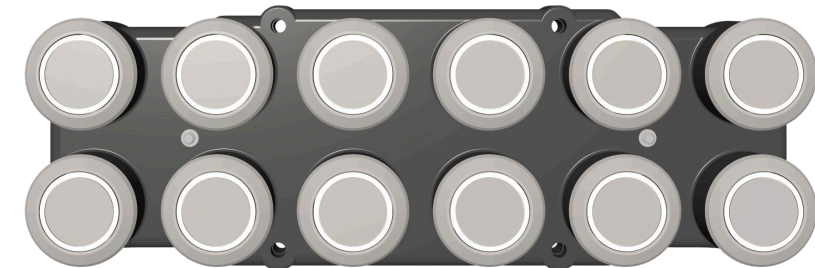

## M1 Dash Module

Behind Dash

### Spyder PN

BENCZM7C1

### Tiffin PN

5170290

### Dimensions

10.8" X 3.5"

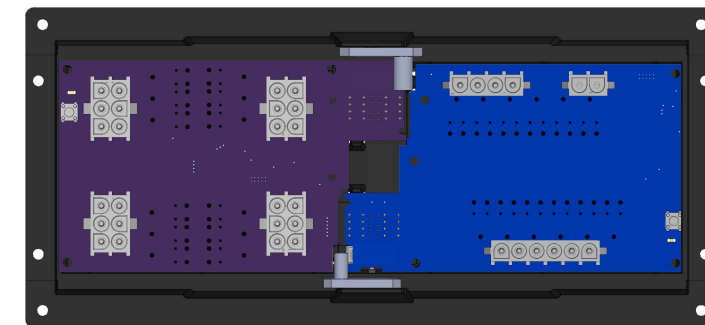

## M1 Pinouts

# Phaeton Dash M1 Panel Pinout

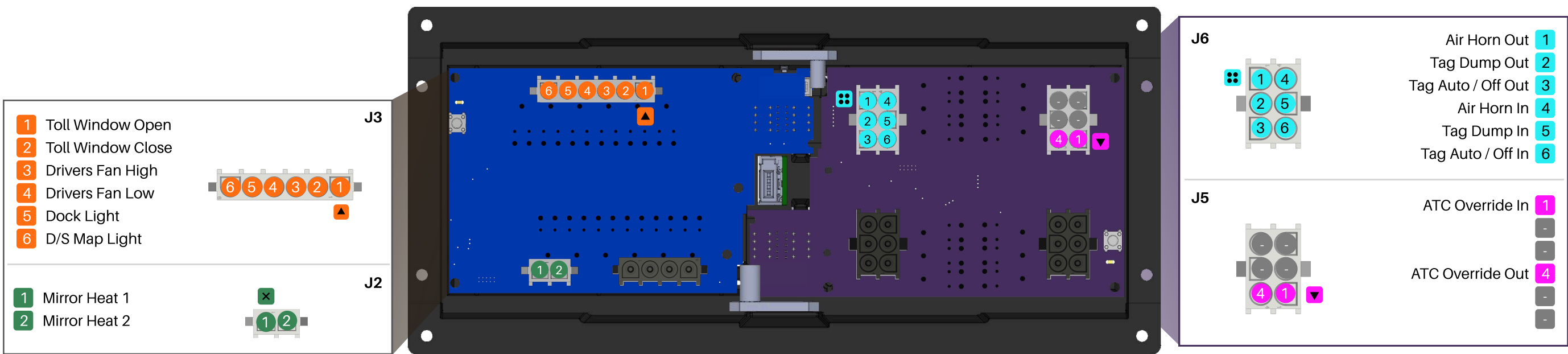

**J3**

- 1 Toll Window Open
- 2 Toll Window Close
- 3 Drivers Fan High
- 4 Drivers Fan Low
- 5 Dock Light
- 6 D/S Map Light

**J2**

- 1 Mirror Heat 1
- 2 Mirror Heat 2

**J6**

- Air Horn Out 1
- Tag Dump Out 2
- Tag Auto / Off Out 3
- Air Horn In 4
- Tag Dump In 5
- Tag Auto / Off In 6

**J5**

- ATC Override In 1
- ATC Override Out 4

### Dip Switch Settings

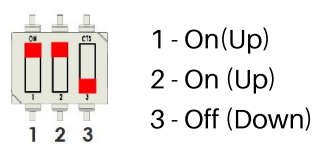

# Phaeton Front M1 Panel Pinout

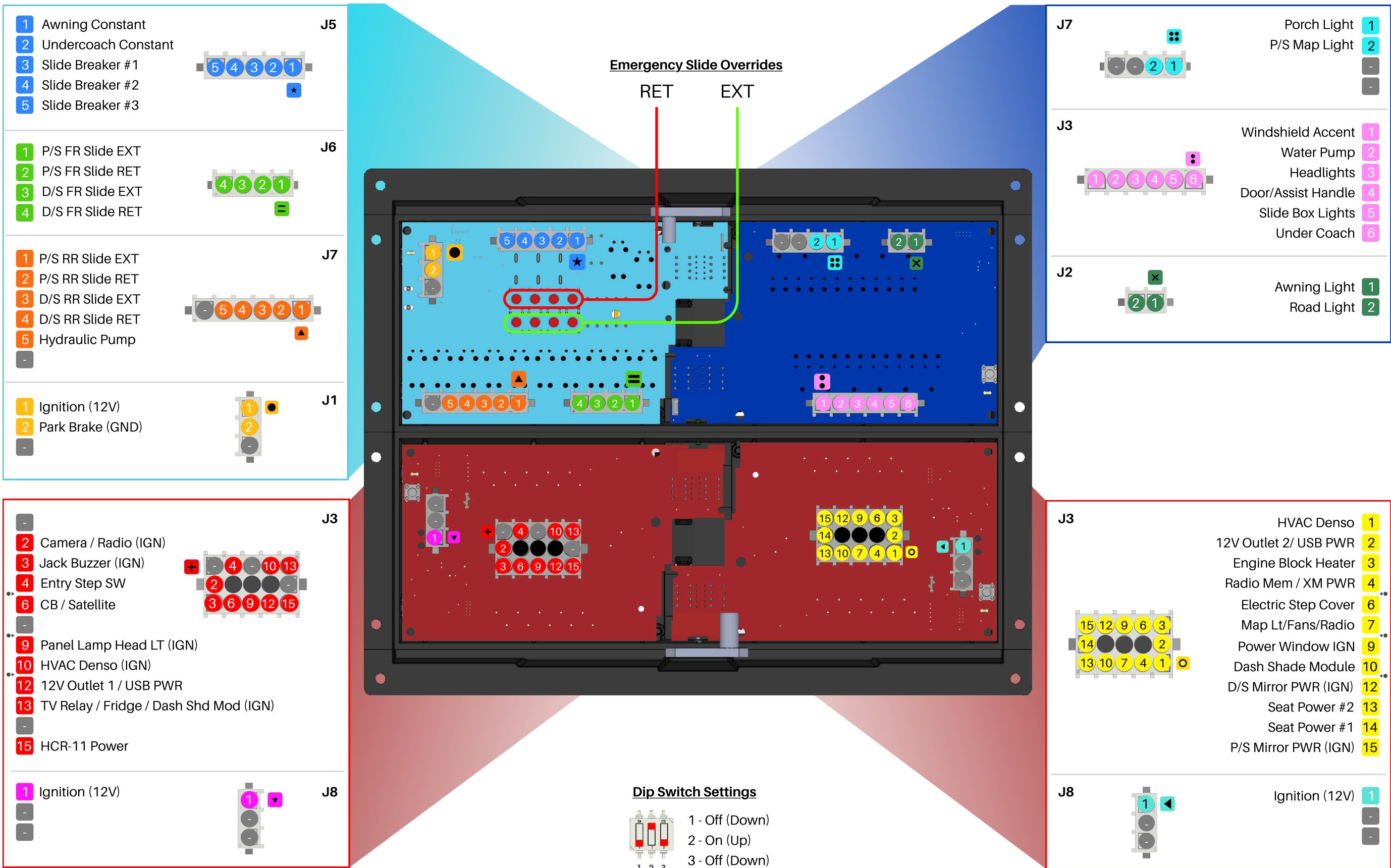

# Phaeton Mid M1 Panel Pinout

**J7**

- 1 Door Awning EXT
- 2 Door Awning RET
- 3 Entry Door Lock
- 4 Entry Door Unlock

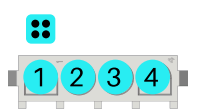

**J3**

- 1 Bed Lift Up
- 2 Bed Lift Down
- 3 PS Fan High
- 4 PS Fan Low
- 5 Bay Door Lock
- 6 Bay Door Unlock



**J2**

- 1 Step Cover EXT
- 2 Step Cover RET



**J2**

- 1 IGN (+12V)
- 2 GEN Fault (+12V)
- 3 HSE Disconnect Sense (+12V)
- 4 Bed Lift Plunger (+12V)
- 9 Park Brake (GND)
- 10 Water Pump (GND)
- 11 Entry Door Pin SW (GND)
- 12 Merge Input (GND)
- Spare
- Spare
- 15 A/C Override (GND)

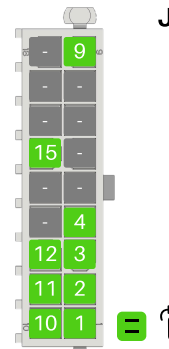

**J4**

- 1 FR Floor HT Therm Sig.
- 2 RR Floor HT Therm Sig.
- 3 Front A/C Therm Sig.
- 4 Mid A/C Therm Sig.
- 5 Rear A/C Therm Sig.
- 6 Bay Therm Sig.
- 7 FR Floor HT Therm GND
- 8 RR Floor HT Therm GND
- 9 Front A/C Therm GND
- 10 Mid A/C Therm GND
- 11 Rear A/C Therm GND
- 12 Bay Therm GND

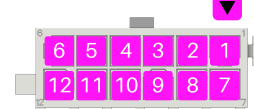

**J5**

- 4 Ext Temp Sig.
- 8 Ext Temp GND

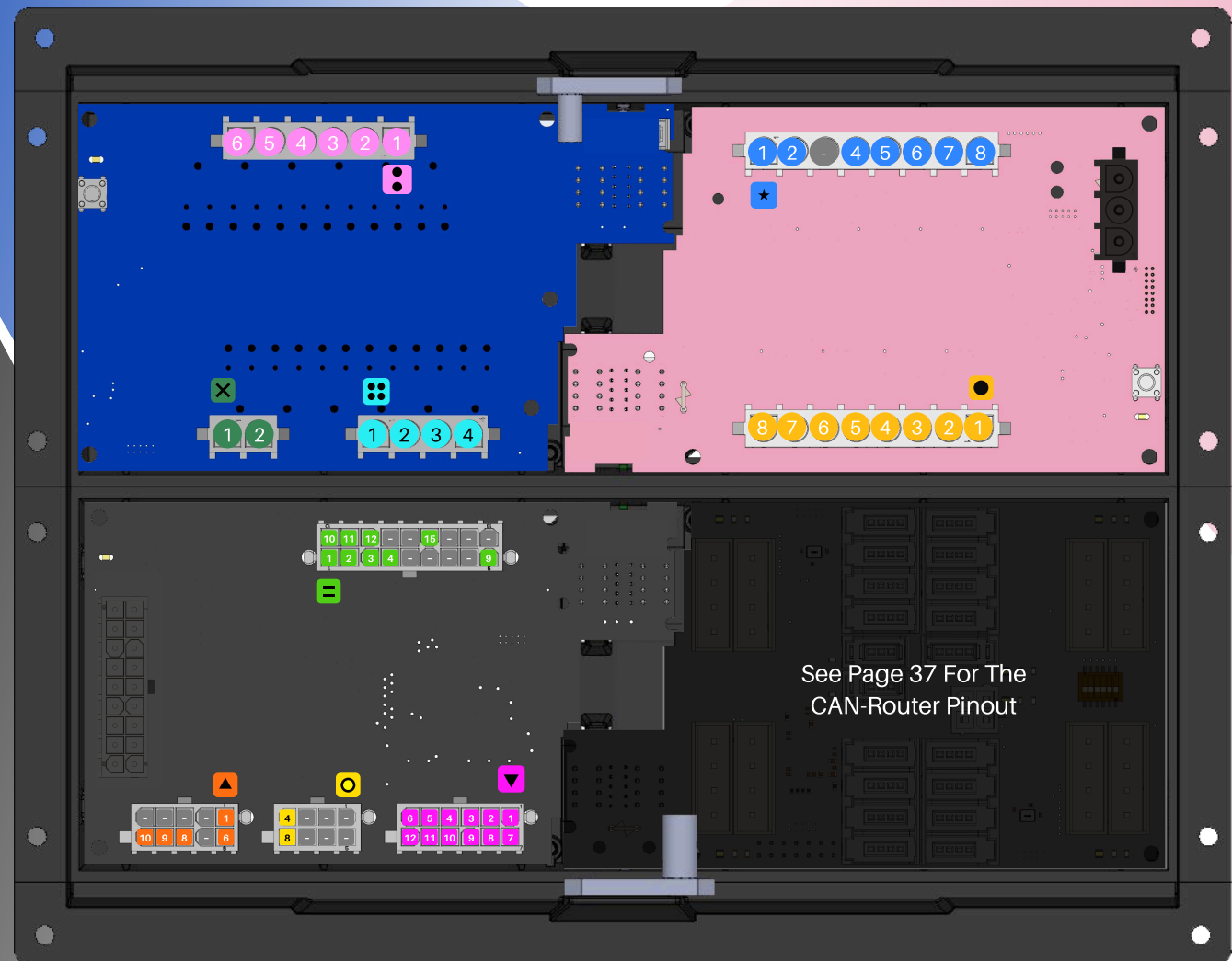
**J6**

- 1 LP Gas Sig.
- 6 LP Gas GND
- 8 Dash Sw Brightness (+12V)
- 9 Gen Run Signal (+12V)
- 10 RTC 12V Constant PWR



**J4**

- 1 RR Bath NT Shd Up
- 2 RR Bath NT Shd Dn
- 
- 4 Horn (GND)
- 5 Furnace FR
- 6 Furnace RR
- 7 Gen Start (GND)
- 8 Gen Stop (GND)



**J2**

- 1 Galley Shade Up
- 2 Galley Shade Dn
- 3 Galley NT Shade Up
- 4 Galley NT Shade Dn
- 5 Sofa Day Shade Up
- 6 Sofa Day Shade Dn
- 7 Sofa NT Shade Up
- 8 Sofa NT Shade Dn

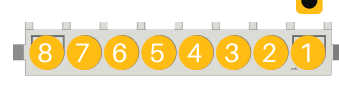

**J9**

- Not Used



### Dip Switch Settings

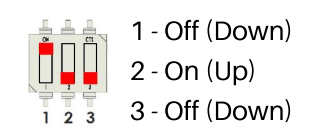

# Phaeton Rear M1 Panel Pinout

**J1**

- 1 Entry Light
- 2 Main OH/ Living Light
- 
- 4 PS Ceiling Light
- 5 DS Ceiling Light
- 6 Dash Light
- 7 Front Sconce Light
- 8 Rear Sconce Light
- 9 D/S Slide Light
- 10 P/S Slide Light
- 11 Front Courtesy Light
- 12 Rear Courtesy Light

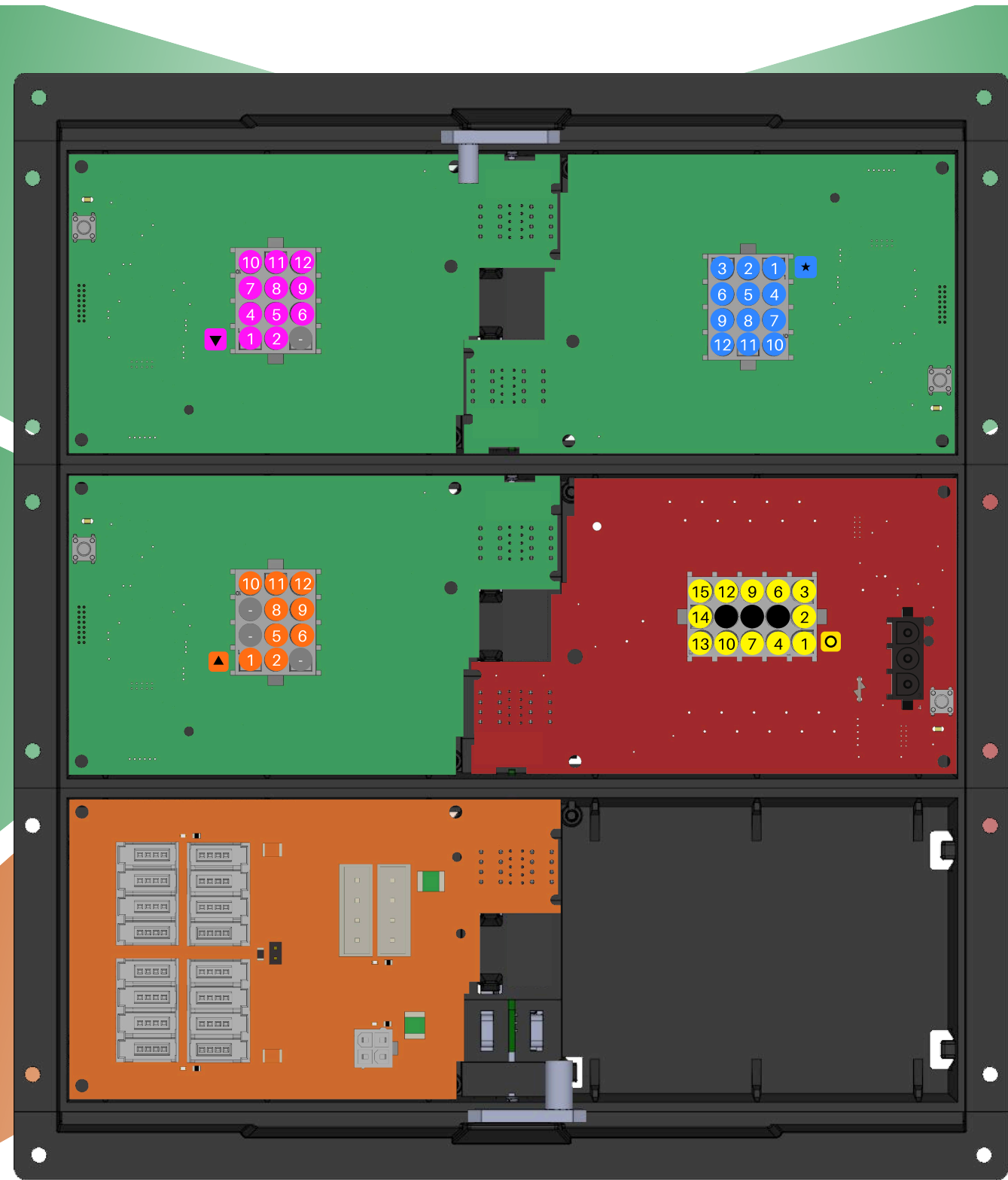

**J1**

- 1 Bedroom Ceiling Light
- 2 Bed Accent Light
- 3 Front Accent Light Ch.1
- 4 Front Accent Light Ch.2
- 5 Task Light
- 6 Mid Bath Light
- 7 Mid Bath Vanity Light
- 8 Rear Bath Light
- 9 Rear Bath Vanity Light
- 10 Front Bed Reading Light
- 11 Rear Bed Reading Light
- 12 Rear Accent Light

**J2**

- 1 TV Accent Light
- 2 Closet Light
- 
- 
- 5 Floor Heat Front Zone
- 6 Floor Heat Rear Zone
- 
- 8 Fireplace Override
- 9 Rear TV Lift Up
- 10 Rear TV Lift Down
- 11 Ceiling Fan High
- 12 Ceiling Fan Low

**J3**

- 1 FR/RR TV Lift
- 2 Basement 12V PWR/Ext TV 12V
- 3 Seelevel
- 4 Truma Water Heater
- 5 Front Furnace
- 6 Bed Slide /Wall USB
- 7 AC Relay Sw/Gly Motn LT
- 8 FR Pass Slide/ Dinette Shd
- 9 Switcher /IR Blaster
- 10 Mid Toilet
- 11 Rear Furnace
- 12 Vent Fan Power

**Network Card**

Network cables can be connected to the back of this card to allow communication between Spyder Devices.

A terminator jumper is placed on this card, when connected this jumper turns the network card into a terminator.

**J8**

Not Used

### Dip Switch Settings

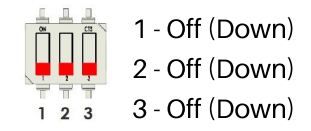

# SSP25 Button Layout

Dash SSP25

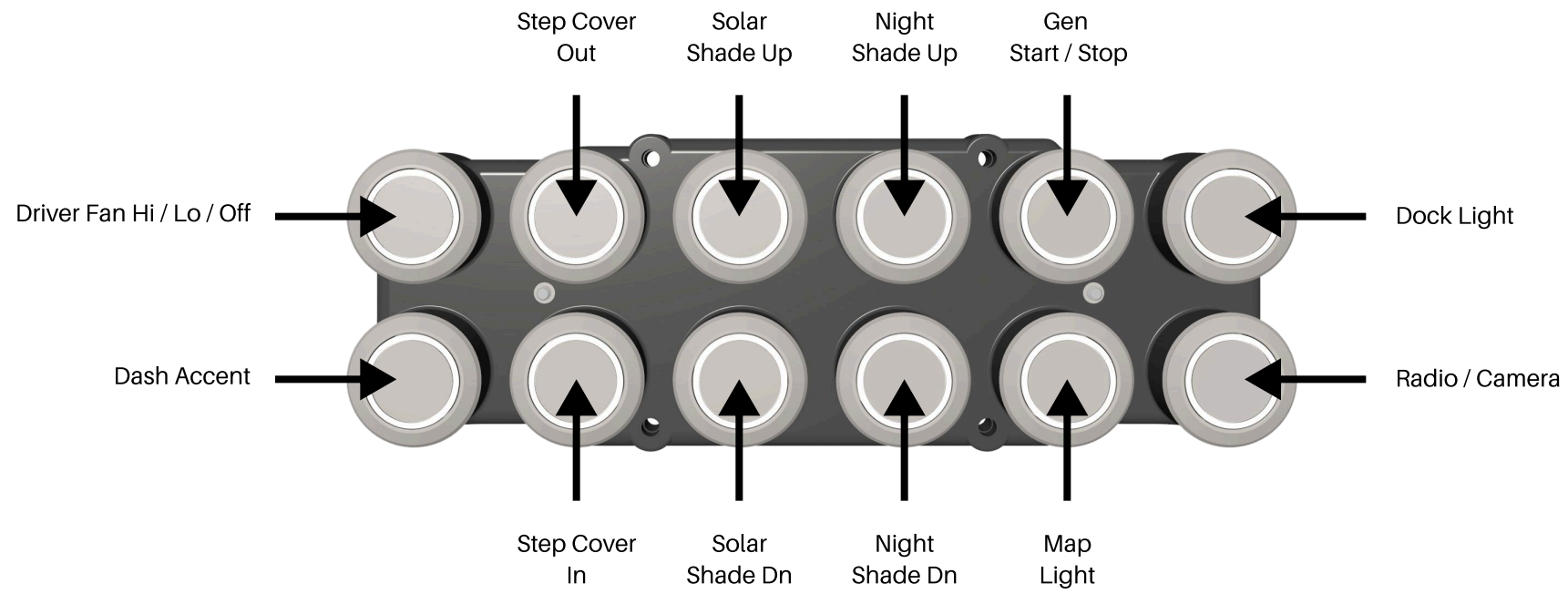

D/S Console SSP25

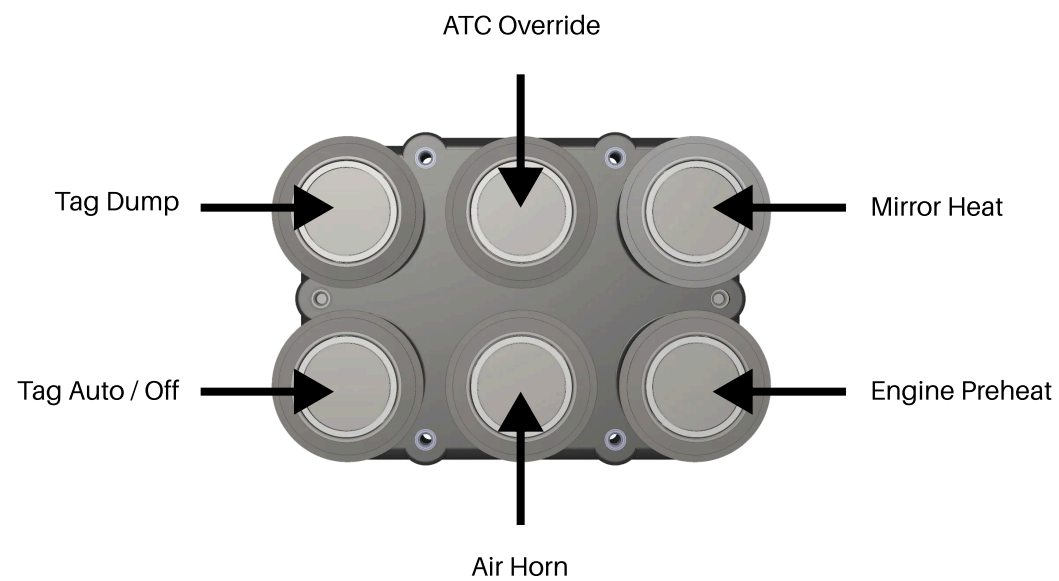

D/S Console SSP25

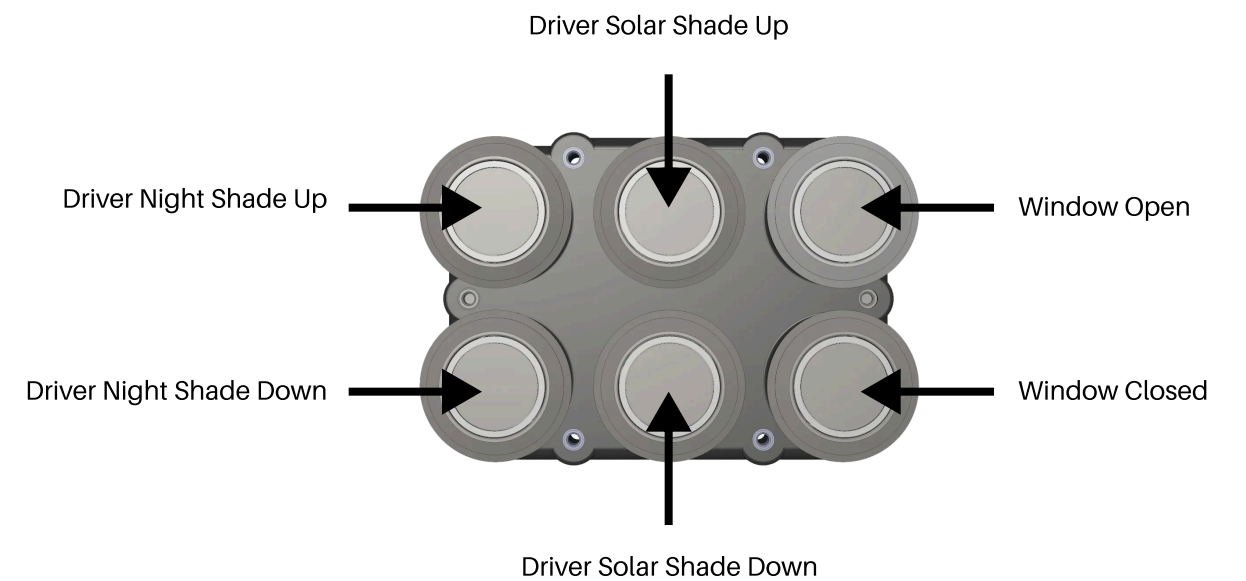

# Mechanical Systems

# Slides

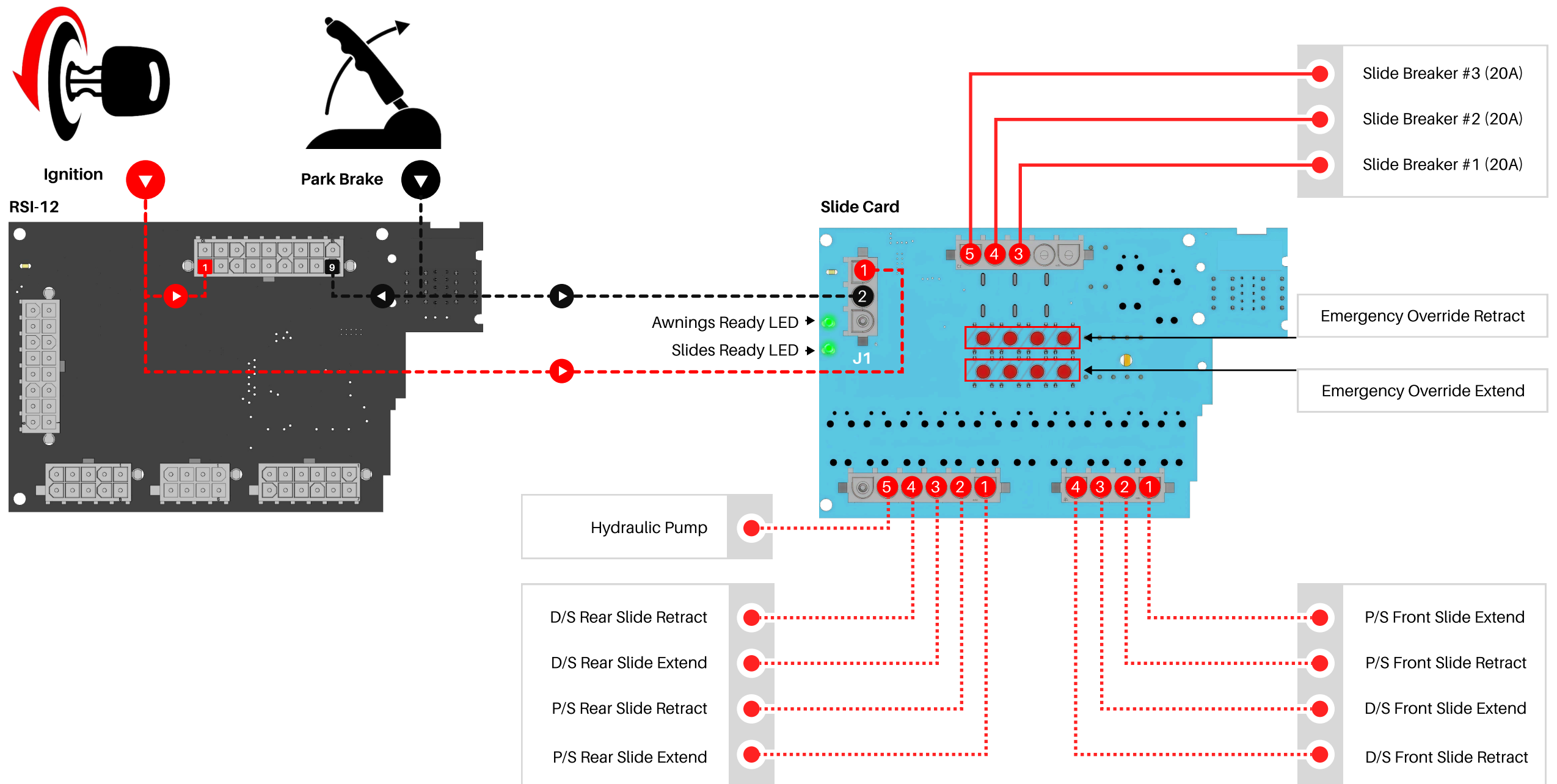

## Slide Safety And Overrides

To ensure safe and predictable slide operation, several safety measures are built into the Spyder system. The core of these protections is the **park brake and ignition interlock**.

The Slide Card has dedicated park brake and ignition inputs. These act as a **physical lockout**: if 12V+ and GND are not present at the Slide Card (J1) before operating the slides, the **slides will not extend**. The RSI-12 also receives secondary park brake and ignition inputs. These inputs send a message over the Spyder Network telling all devices that park brake and ignition are active.

Because the safety inputs are split between the RSI-12 and the Slide Card, certain wiring issues can cause the LCD to show **"Slides Ready"** even though the slides will not operate. If you encounter slide issues, check the Slides Ready LED on the Slide Card in the front M1 panel.



- In the event of a system failure, **Emergency Overrides** are available on the **front M1 panel**. To use them, **press and hold one of the red buttons** with a non-metallic object in the direction you want the slide to move. The slide will run while the button is held and stop when you release it. **Emergency overrides** will only function if park brake and ignition signals are being received by the Slide Card.

# Phaeton Bed Lift

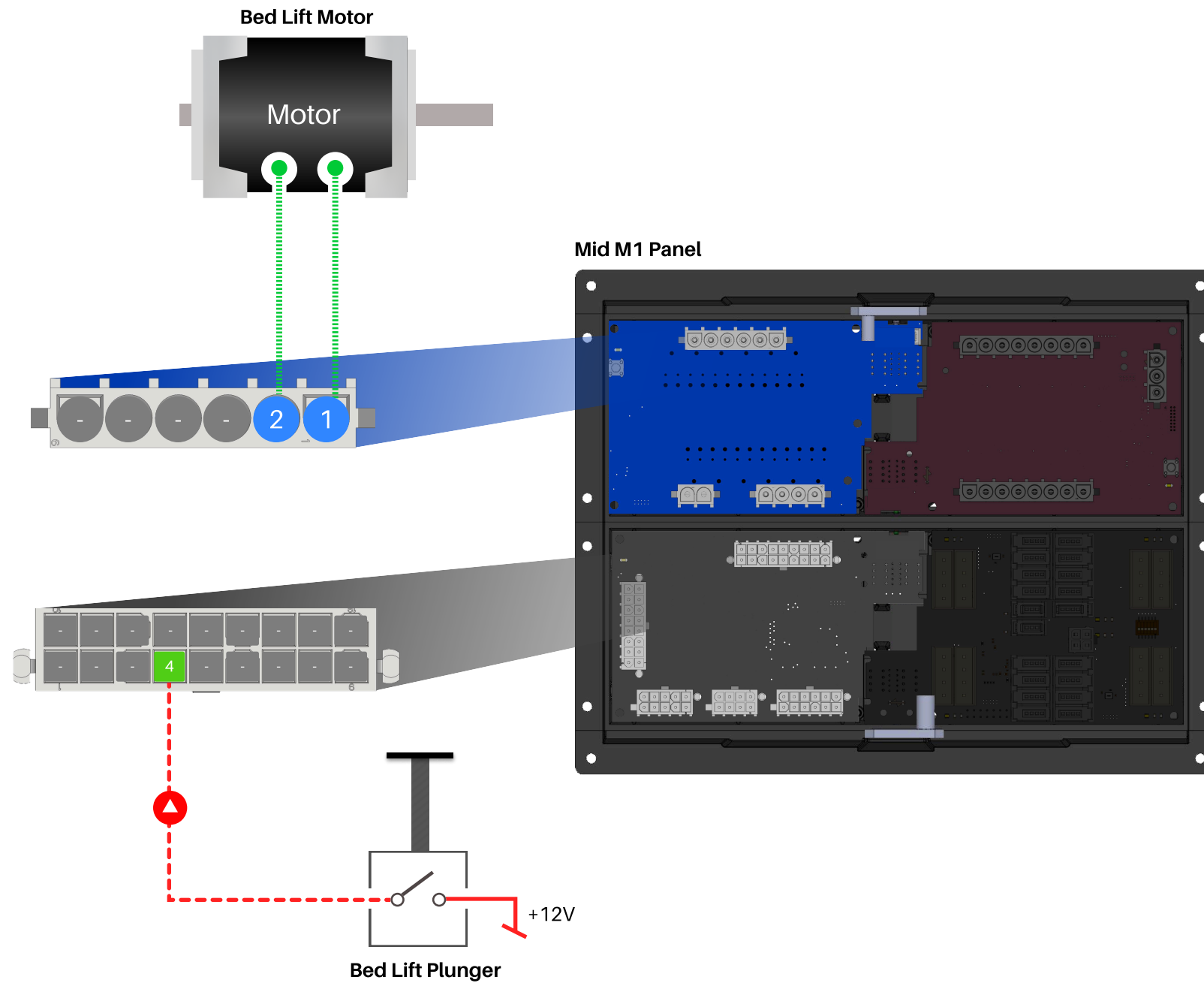

## Bed Lift Operation

If equipped with a bed lift:

When pressed, the bed lift plunger sends +12V to connector J2 Pin 4 on the RSI-12, enabling the slides to operate. If the plunger is not depressed and the RSI-12 does not receive this +12V signal, the slides will not run.

# MoRyde TV Lift

Front TV Lift	Rear TV Lift	Location Settings
		The location setting for the HCR-15 can be changed via connector J5.

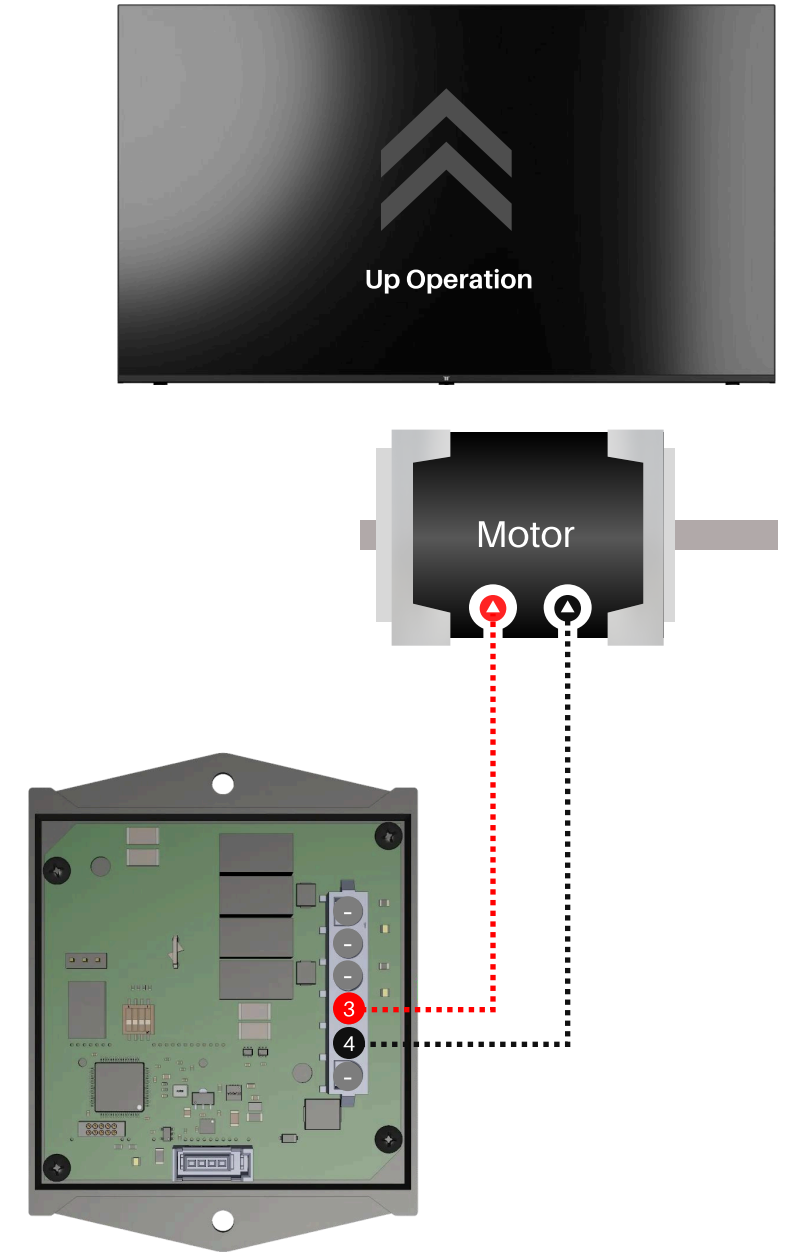
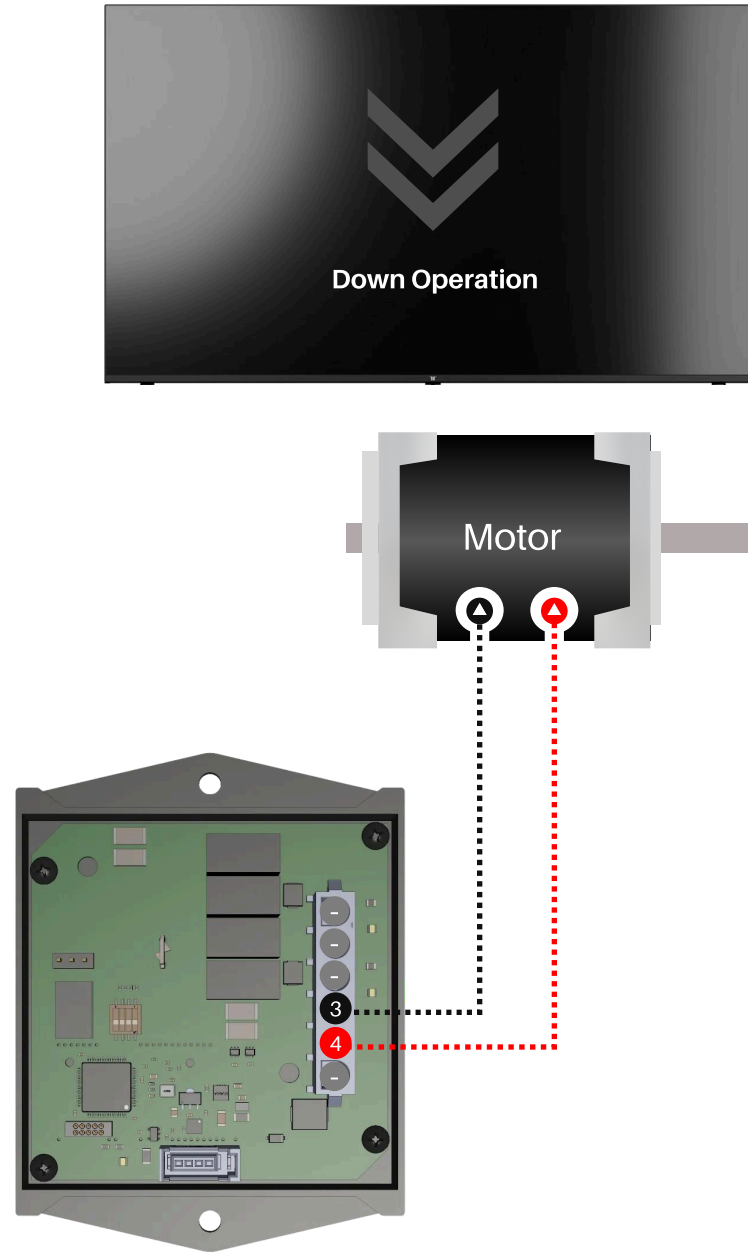
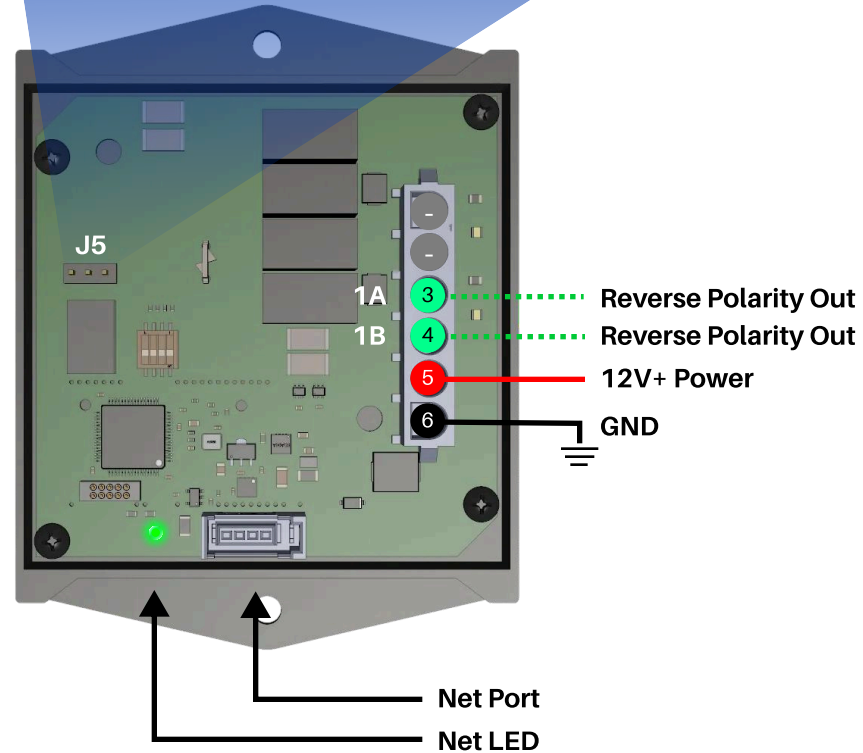

## Trouble Shooting

This information applies **only to coaches with a MoRyde TV Lift**. The module shown above is an HCR-15, which provides the reverse-polarity output needed to drive the MoRyde TV Lift motor. If the TV lift will not raise or lower, first check that the **NET LED** on the **HCR-15** is solid green.

- If it is flashing or off, there is a network connectivity issue.
- If the module is online (solid green LED) but the TV lift still does not work, test the output with a multimeter.

Insert one probe into **1A** and the other into **1B**. Proper operation will show the module outputting **12V+** on one pin and ground on the other, depending on the direction. If this is not occurring, please call **Spyder Controls**.

# Whisper Ride TV Lift

Front TV Lift	Rear TV Lift	Location Settings
		The location setting for the HCR-15 can be changed via connector J5.

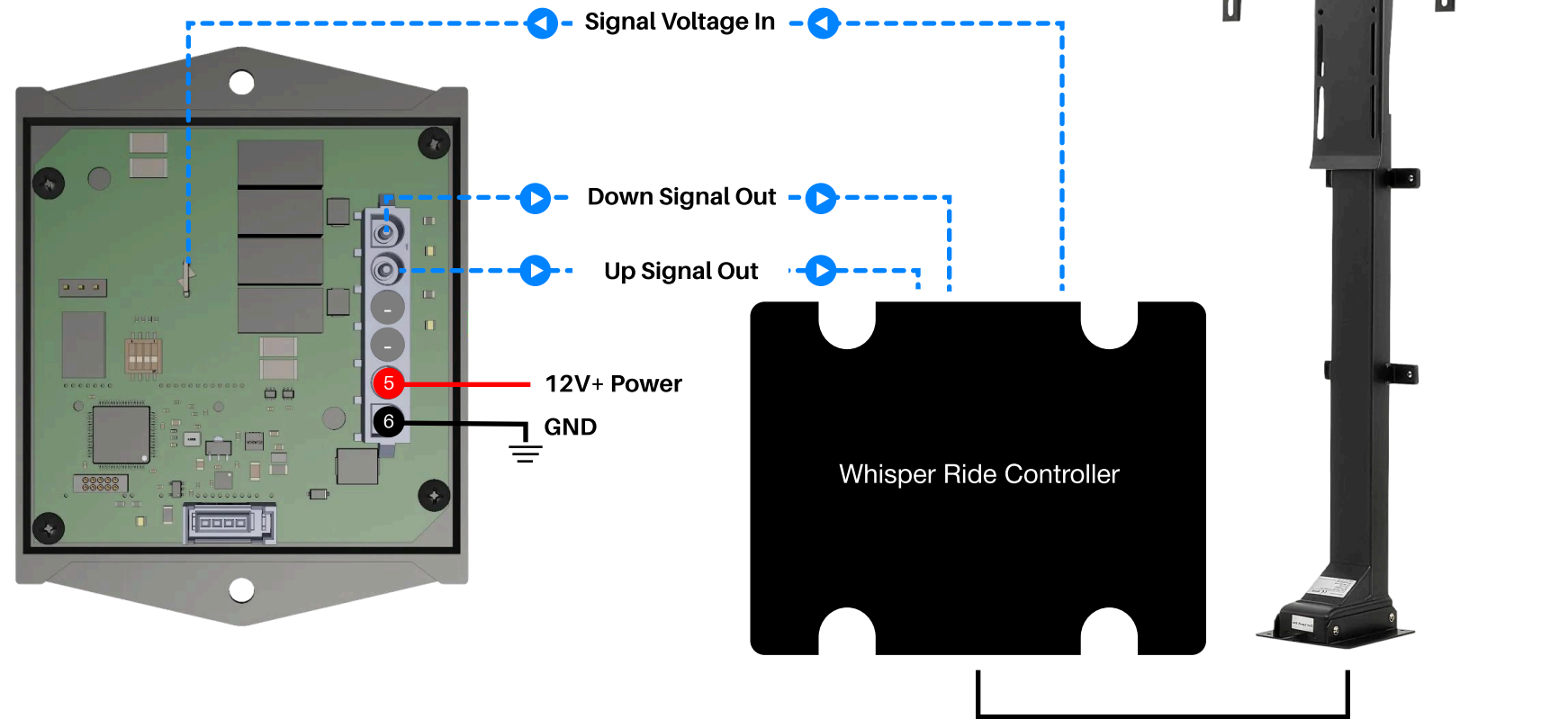
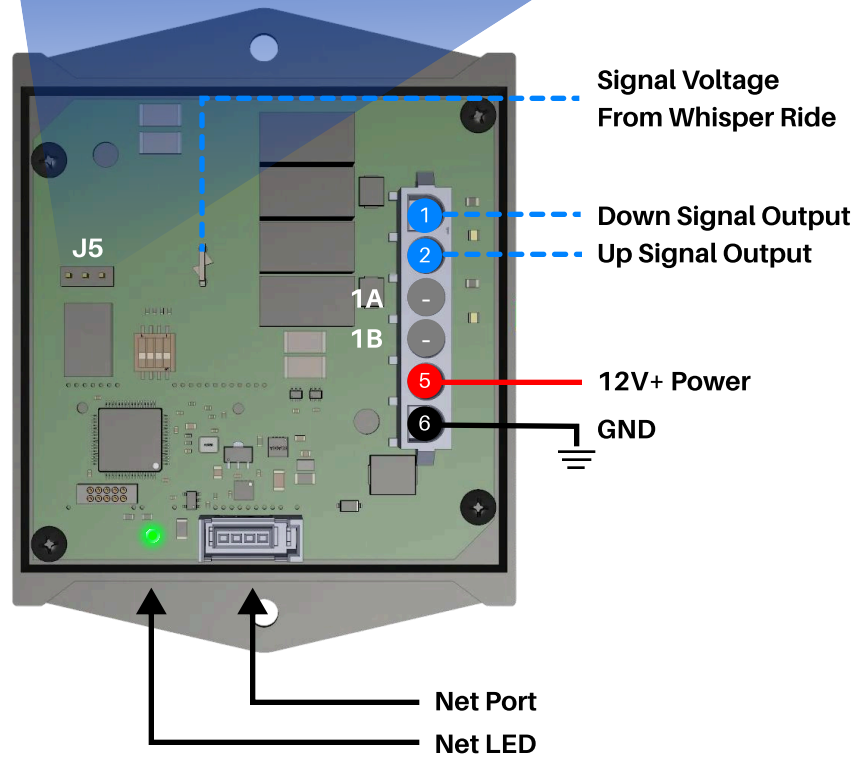

## Trouble Shooting

The module shown below is an **HCR-15**, which provides the **12V** output for the TV lift motor. If the TV lift will not raise or lower, first check that the **NET LED** on the **HCR-15** is solid green.

- If it is flashing or off, there is a network connectivity issue.
- If the module is online (solid green LED) but the lift still does not operate, use a multimeter to probe the connector.

For further troubleshooting, please contact **Spyder Controls**.

# Phaeton Shades

M1 Mid Panel

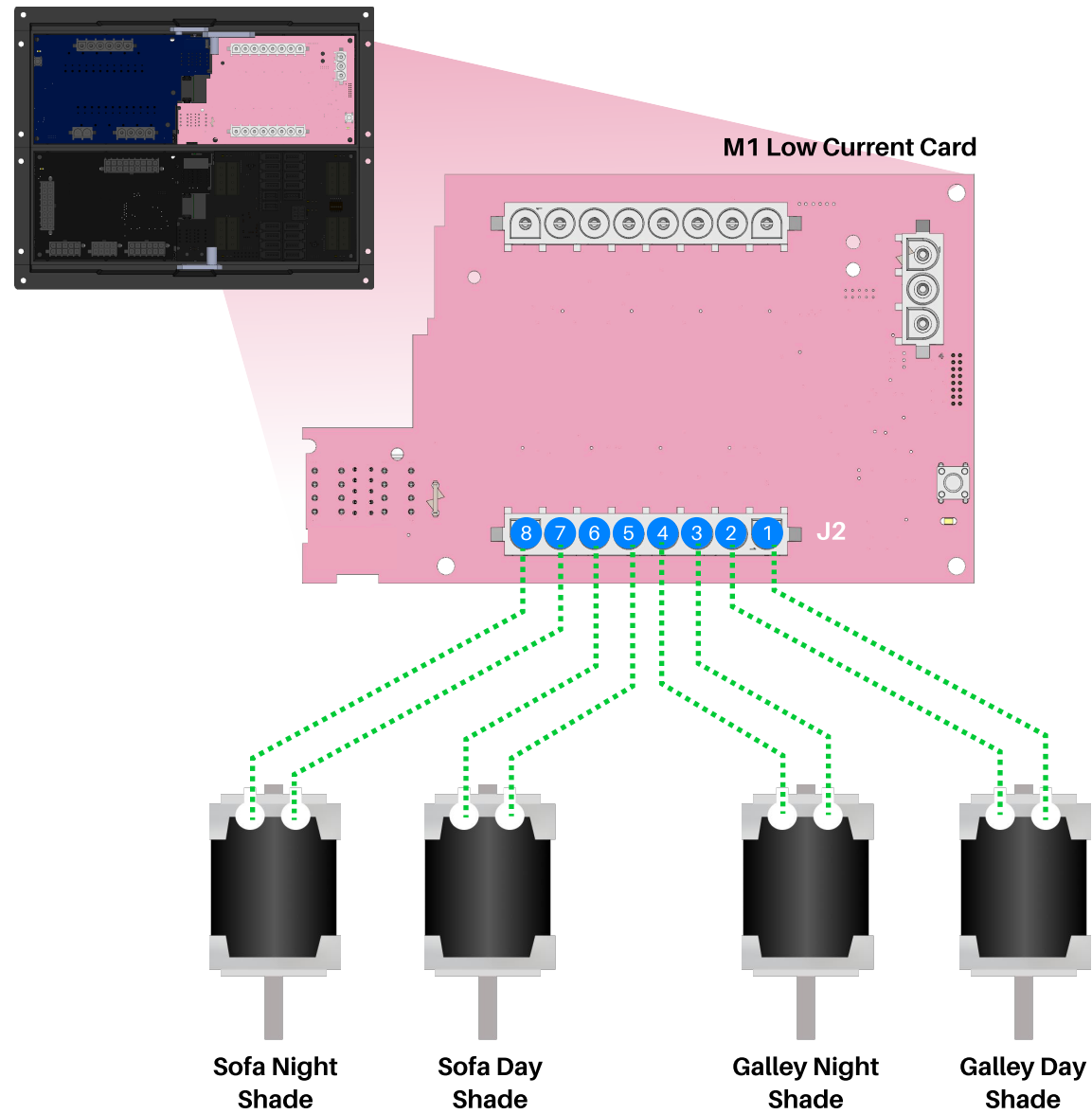

Dash Shade Module

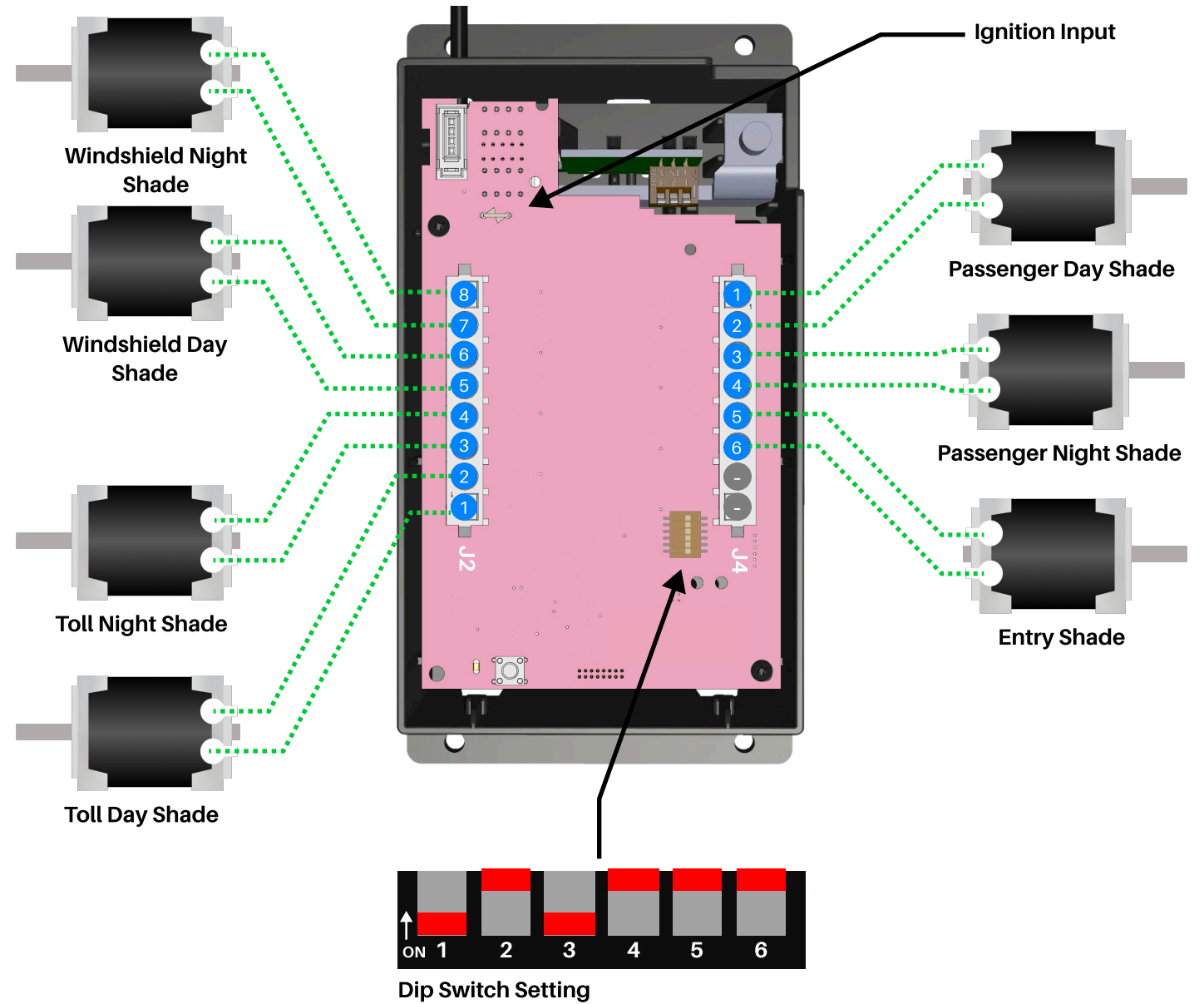

## Dash Shade Ignition Lockout

When the ignition is turned on, the coach sends **12V+** to the **Dash Shade module**. When this signal is received, the module prevents the windshield shade from fully lowering with a single press. To lower the windshield shade **while ignition is present**, you must **press and hold** the windshield shade **Down** button.

# Phaeton Motors And Pump

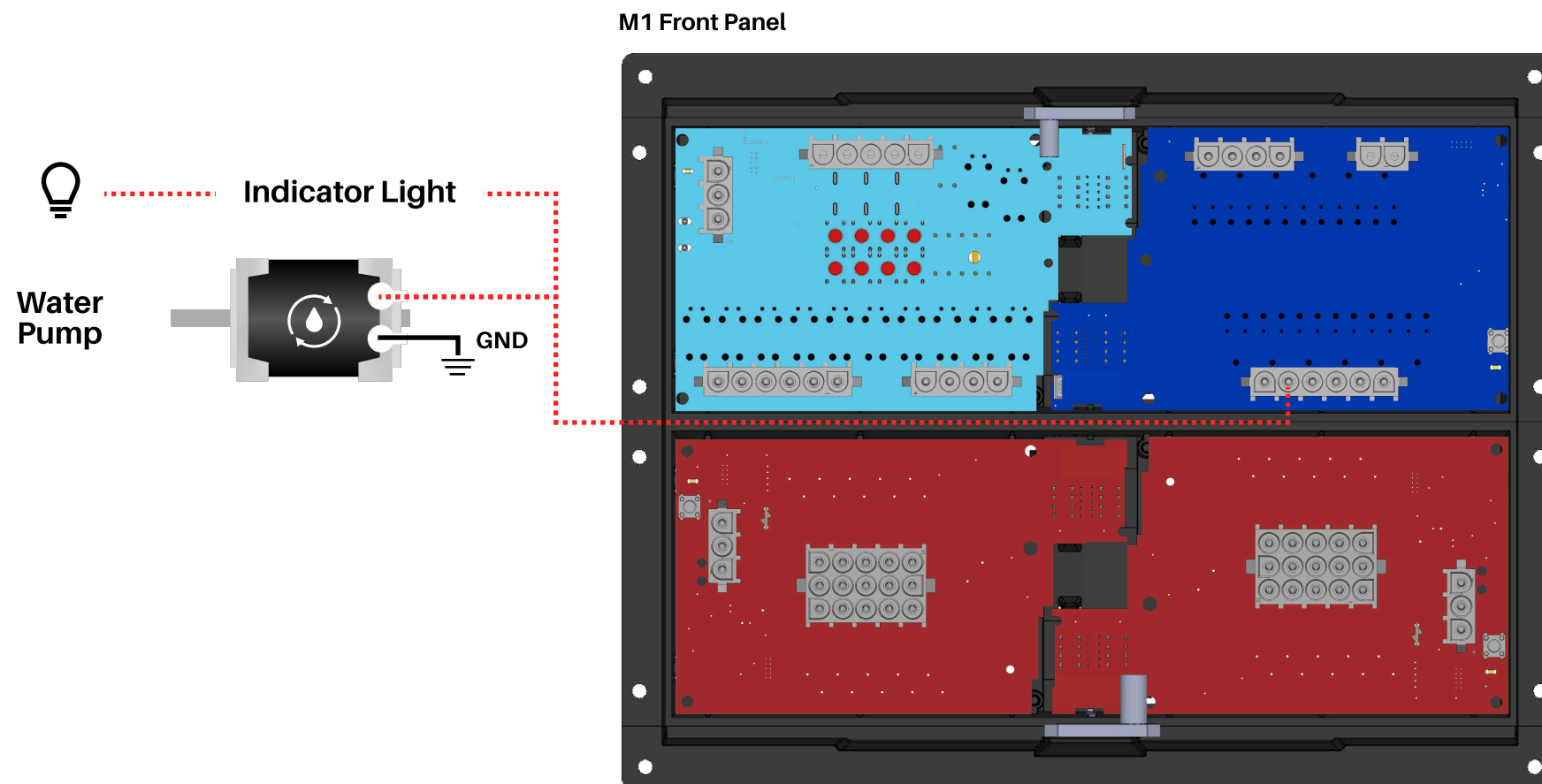
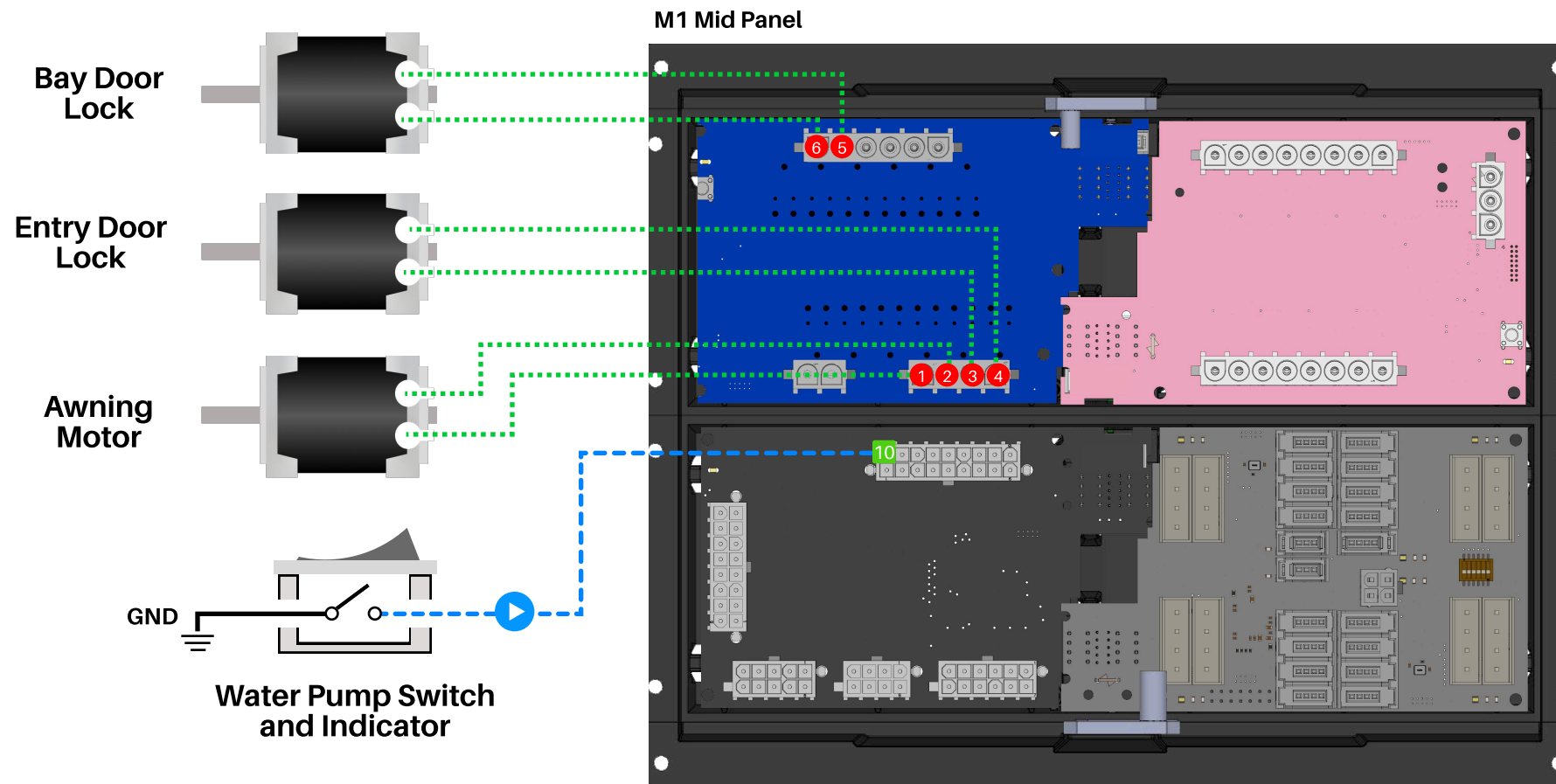

# Tank Sensing

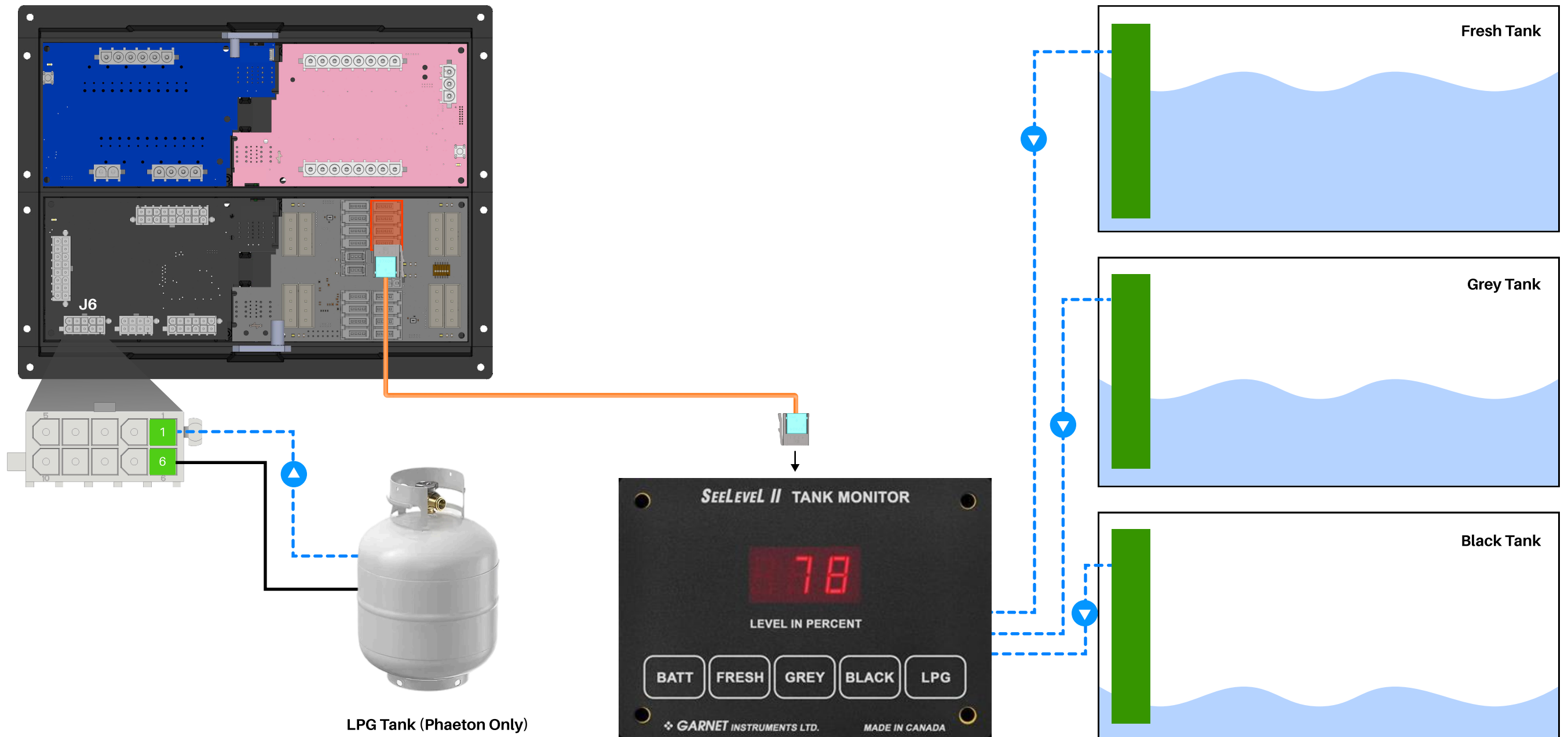

## Tank Sensing

This coach uses a **Seelevel Tank Sensing System** made by **Garnet Industries**. The system reads tank levels using adhesive strip sensors mounted on each tank. The Seelevel monitor then sends this data across the RV-C network.

The Spyder System simply detects and displays the tank information broadcast by Seelevel on all Spyder screens that show tank levels. If the tank readings shown on a Spyder display are incorrect, the issue is not with the Spyder System. Spyder only displays the information provided by the Seelevel monitor.

If **no tank information** appears on the displays, the **Seelevel monitor** may be **offline**.

The **LPG Tank** sensor provides a **resistance value** to the RSI-12 module. This resistance value ranges from **Full (90 Ohms)** to **Empty (0 Ohms)**. This level can be measured at the RSI-12.

# Climate Systems

# HVAC Aircons & Overrides

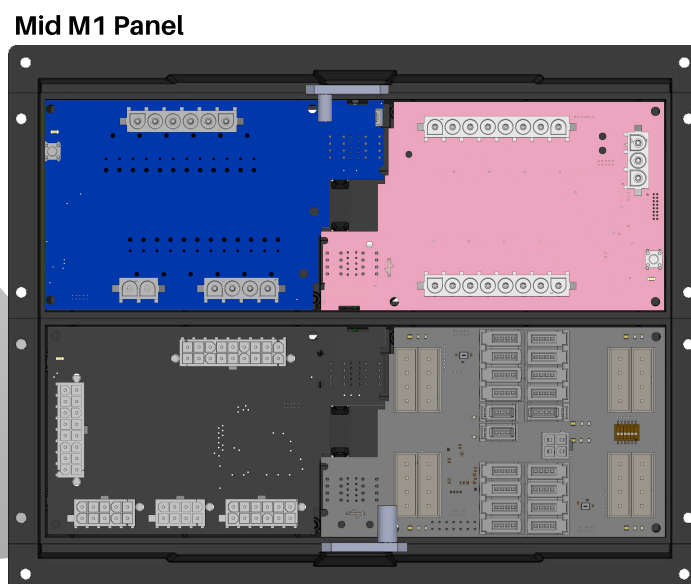
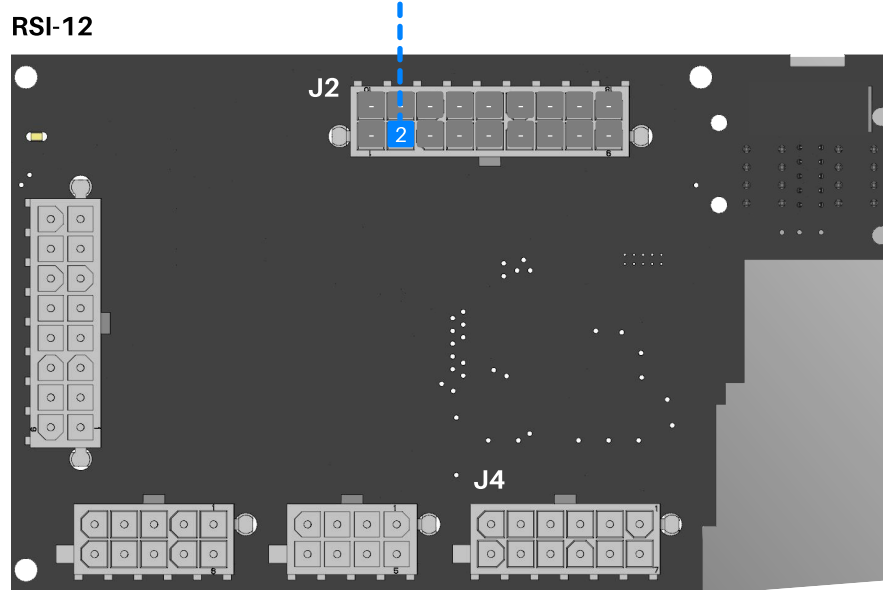
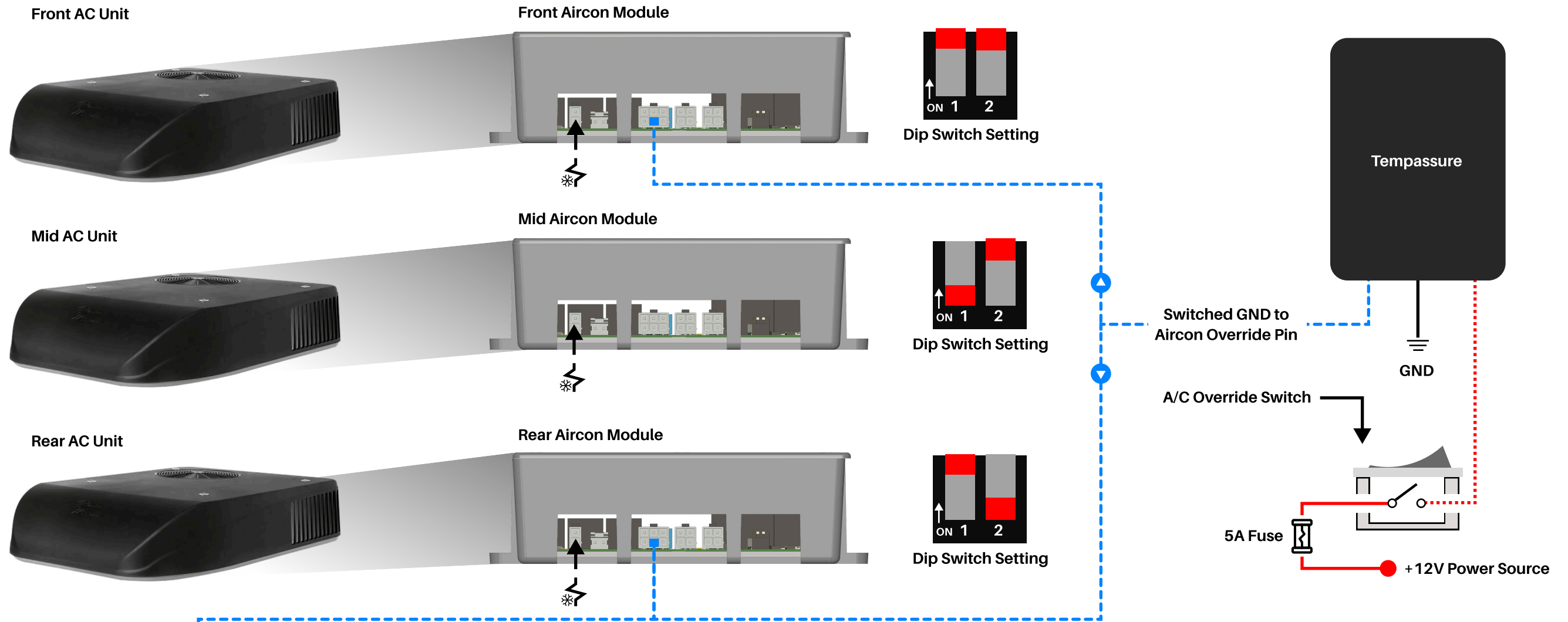

## Emergency HVAC Override

In the event of a system failure, the **front and rear A/C units** can be manually overridden to cool the coach. This **manual override switch** is located in the **rear closet**. Switching it to the **ON** position activates a small module in the ventilation system called the **Tempassure module**, which will then take control of the front and rear air conditioners.

The Tempassure cools the coach **thermostatically**, maintaining a **preset temperature range** determined by the module. This override should be used **only in emergencies** when the A/C units cannot be controlled through the Spyder system.

If you notice the air conditioners turning on and off unexpectedly, the manual override switch may have been accidentally turned on—**switch it OFF** to restore normal operation.

 **A/C Freeze Sensor**  
10K Ohms at 25C / 77F

# HVAC Thermistors

RSI-12

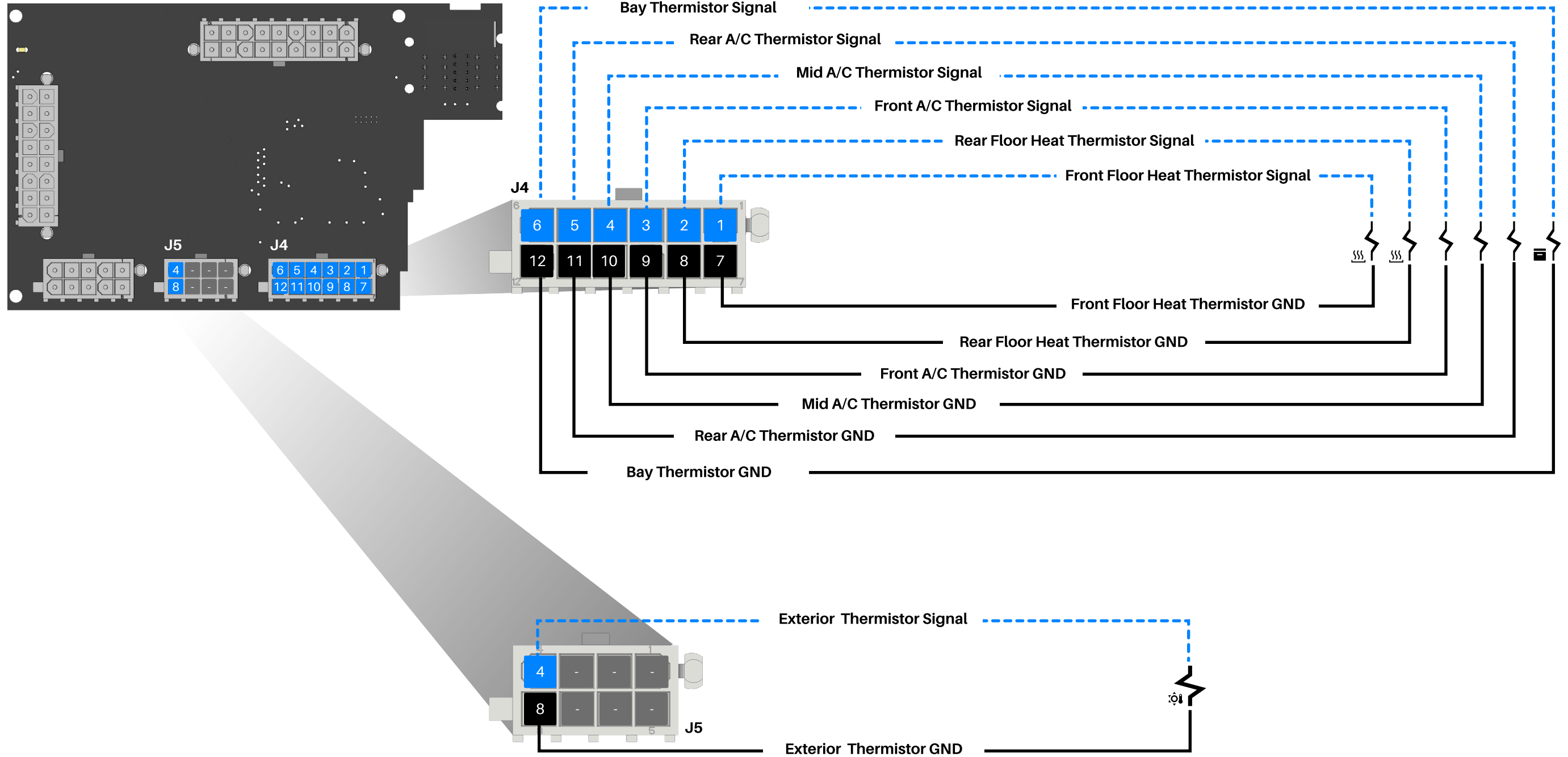

# Floorheat

## Floorheat Set Points

The floor heat system in your coach operates using **levels (1-5)**. Each level corresponds to a specific temperature range. The system heats the floor pad until the selected level is reached, then shuts off and monitors the floor temperature. It will turn back on **automatically** whenever additional heat is needed.

To power a heating pad, a channel in the rear M1 turns on and **sends 12V+** to a **GFCI outlet** in the rear closet. This activates the **120V AC** outlet, which then supplies power to the heating pad.

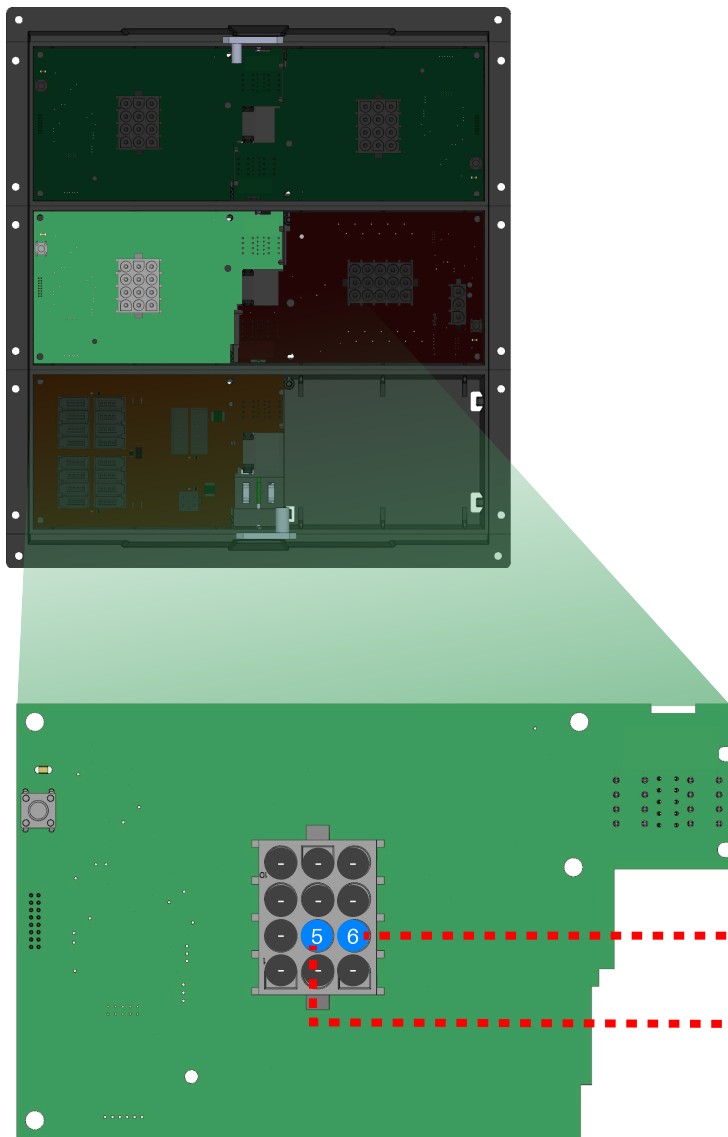

Rear Floorheat Pad

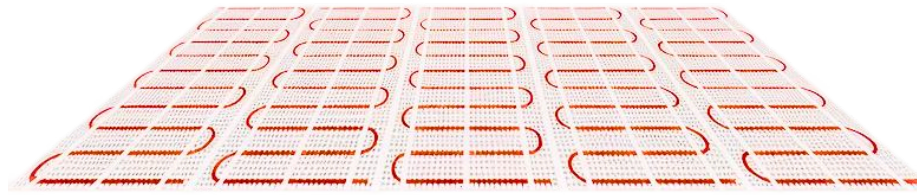

Front Floorheat Pad

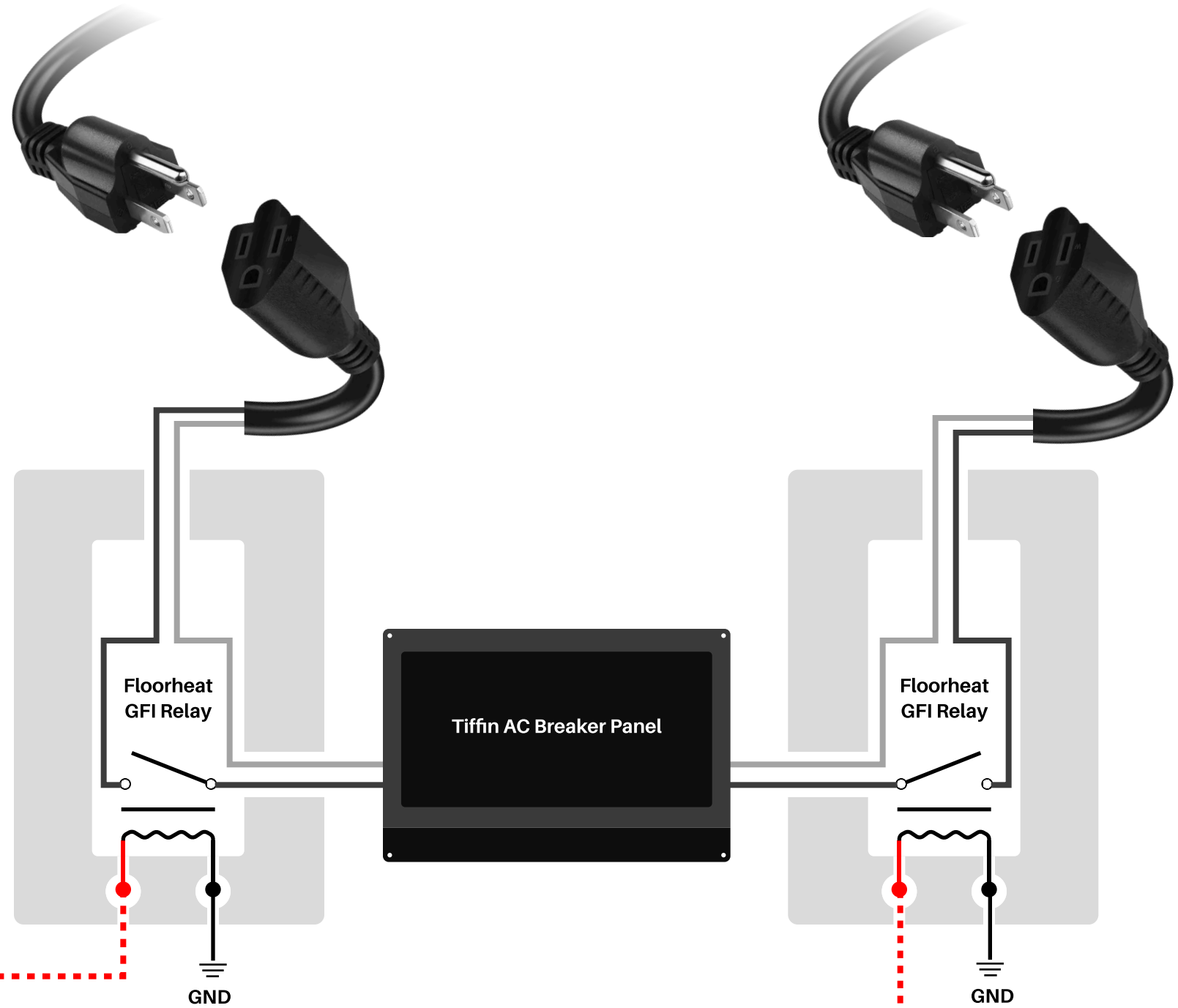
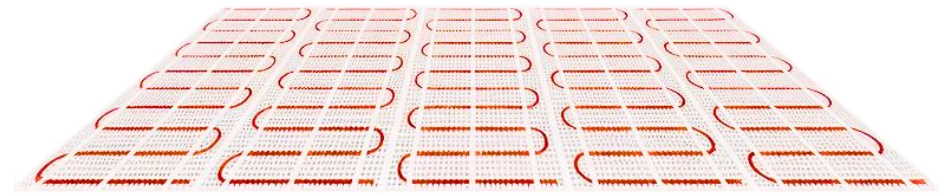

# Vent Fans

Vent Fan Modules - Located in Vent Fans - 1 Per Vent Fan

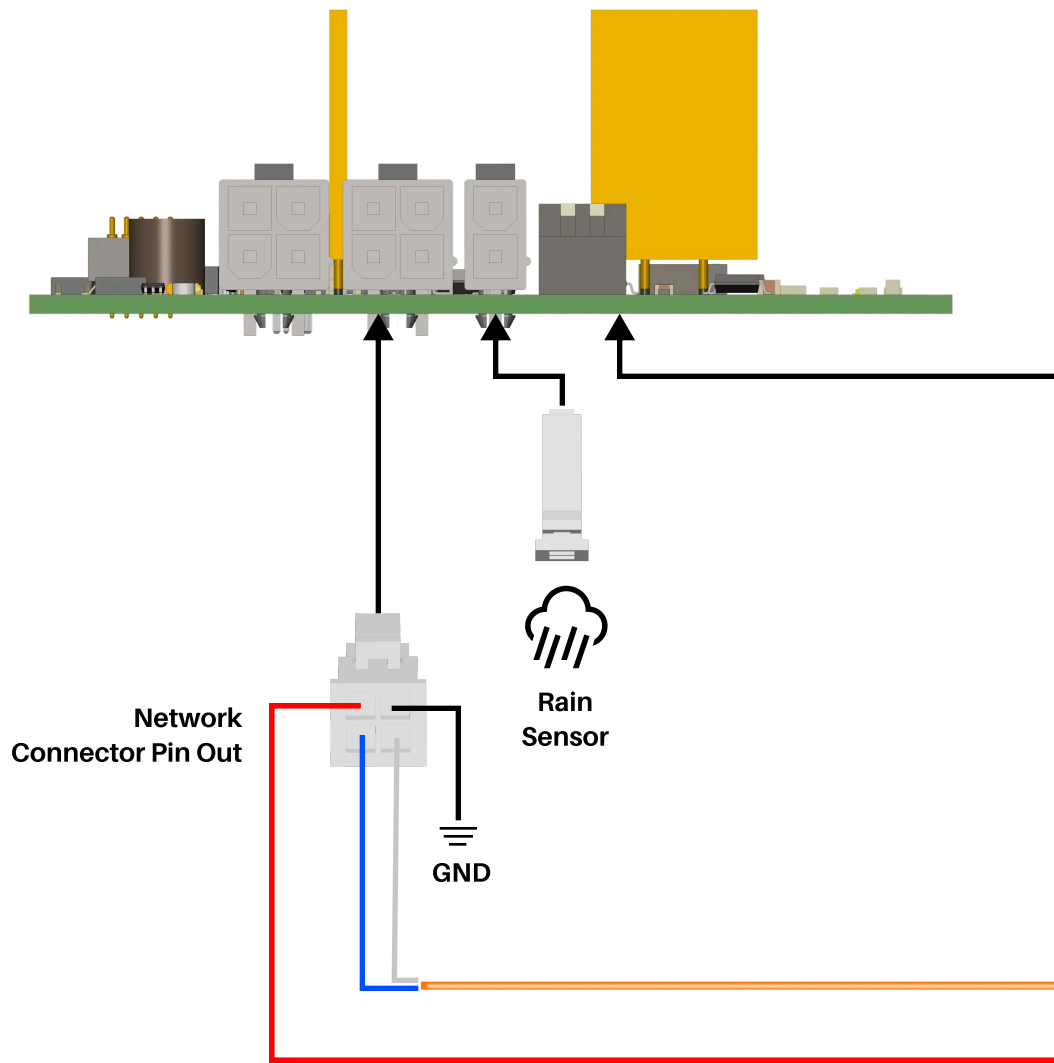

Dip Switch Settings	
Fan Location	Dip Switch Setting
Galley Fan	
Mid Bath Fan	
Rear Bath Fan	

Rear M1 Panel

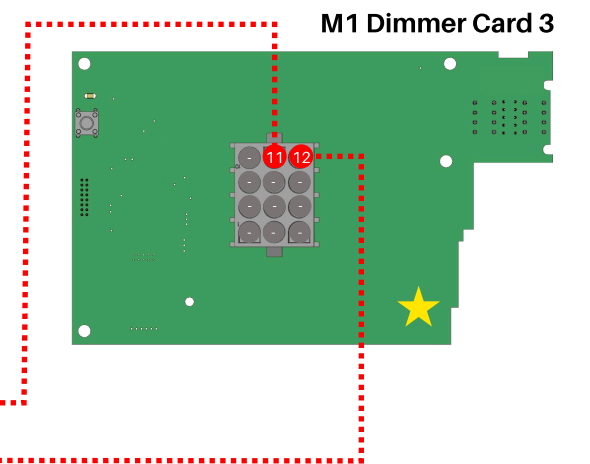
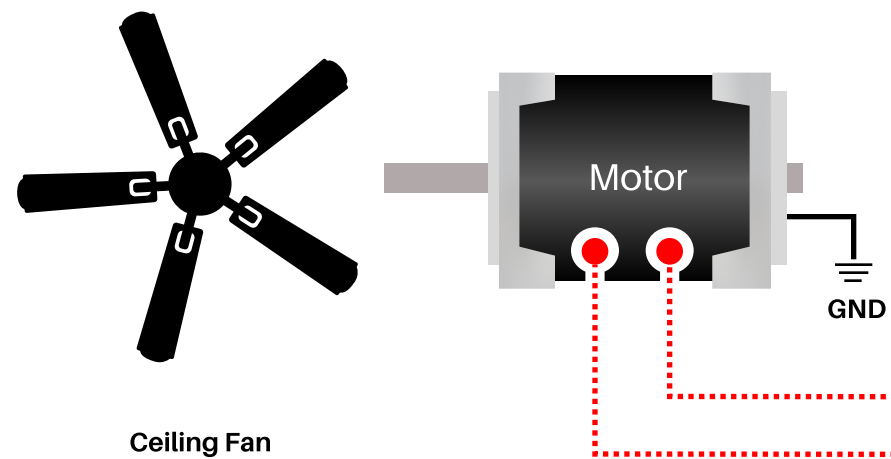
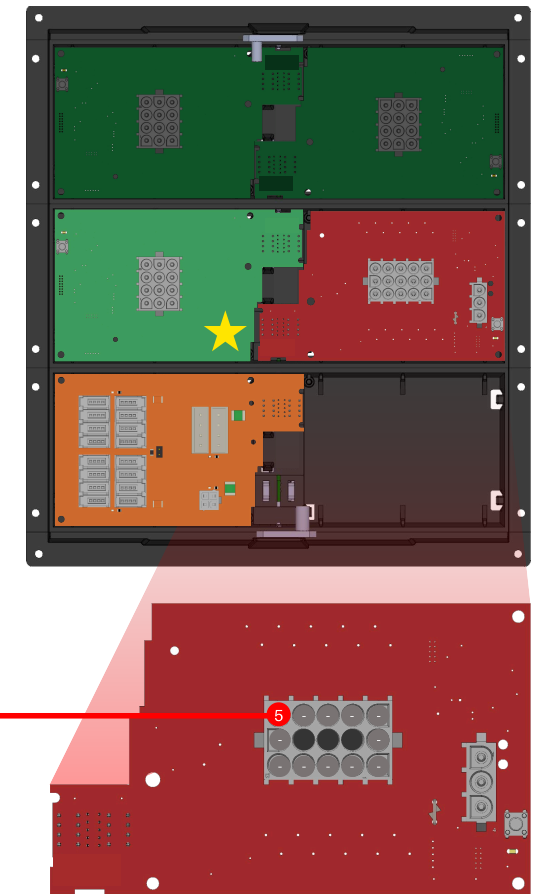

Fan Low Resistor - Tiffin P/N: 5040707

# Power Systems

# Front HCR-11

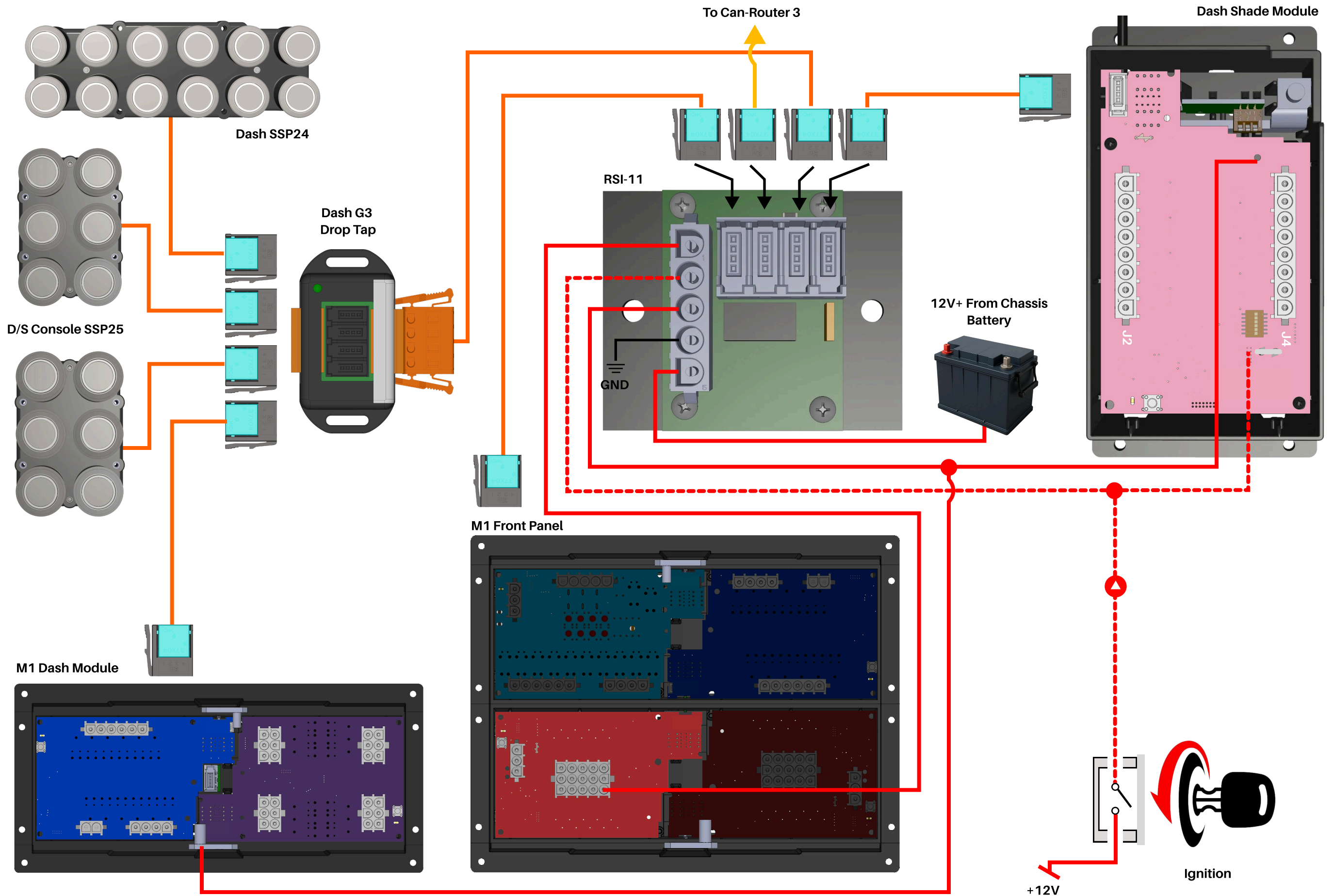

# Battery Merge

## Coach Running Input

Depending on the chassis used in the coach, the coach running input will come from either the engine (switched GND input) or the ignition (switched 12V+ input).



Ignition

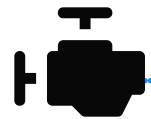

Engine Run

Mergeman Merge Solenoid

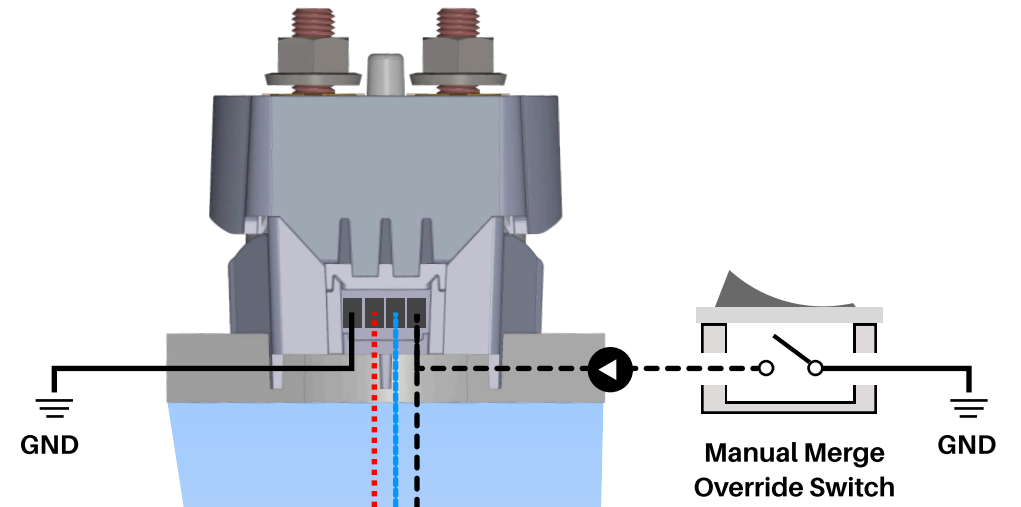

DCD Panel

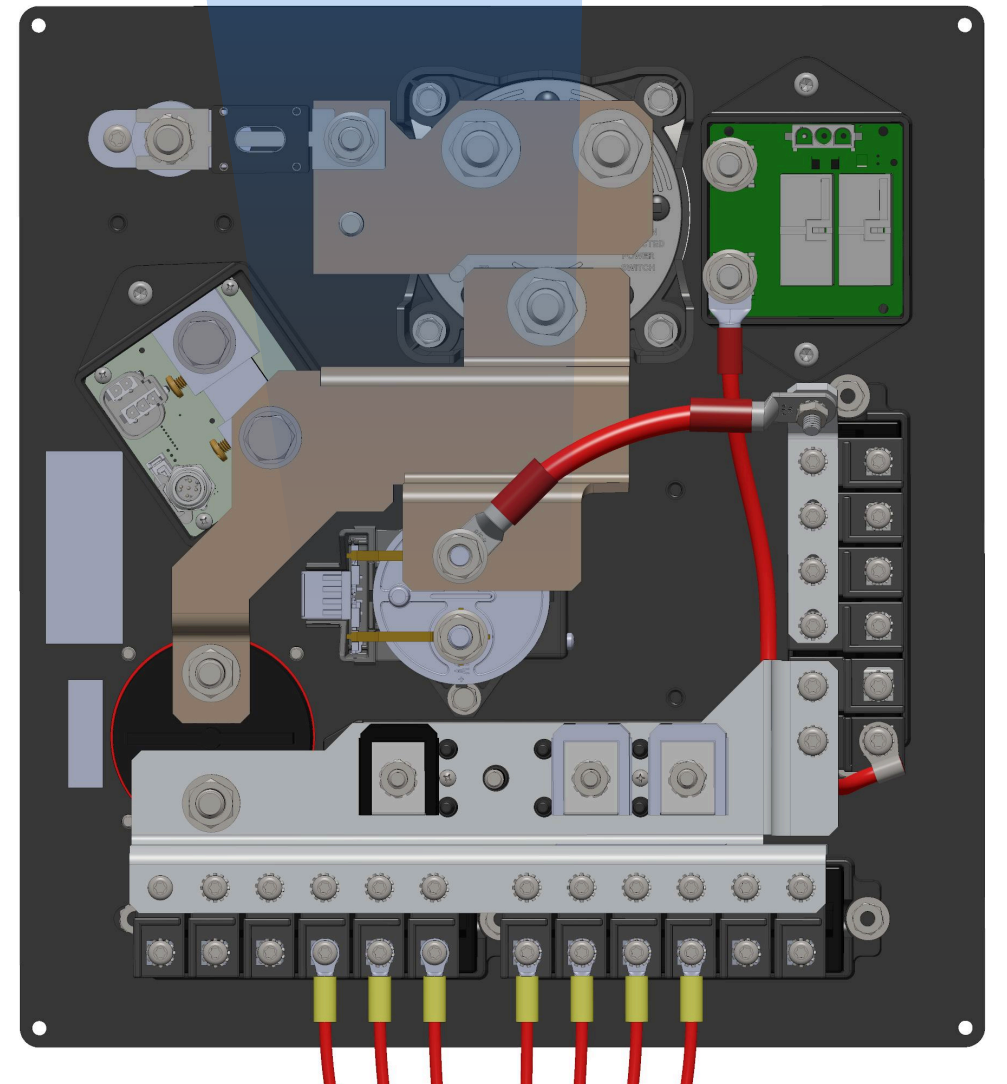

M1 Mid Panel

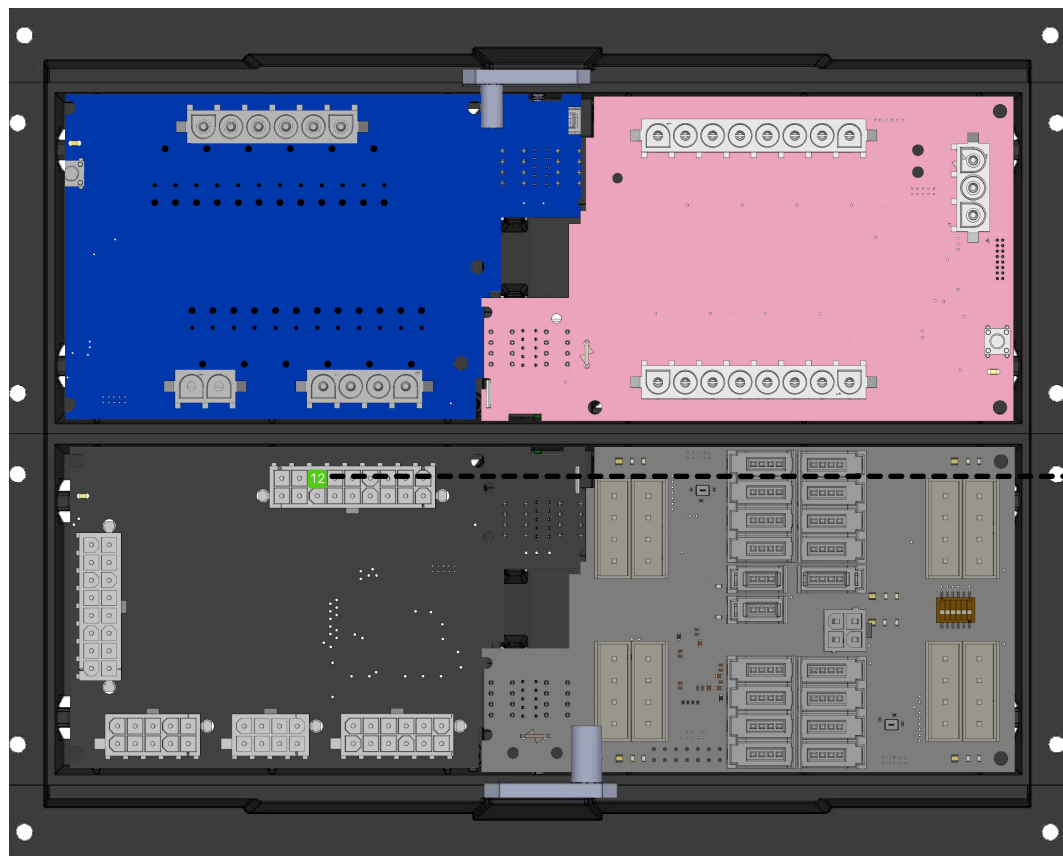

Auto / Manual Merge Input (GND)

# Merge Logic

## What is Battery Merge?

Battery merge is a system that allows your house and chassis battery to share power ensuring both are sufficiently charged in all situations.

## Chassis Charging House State

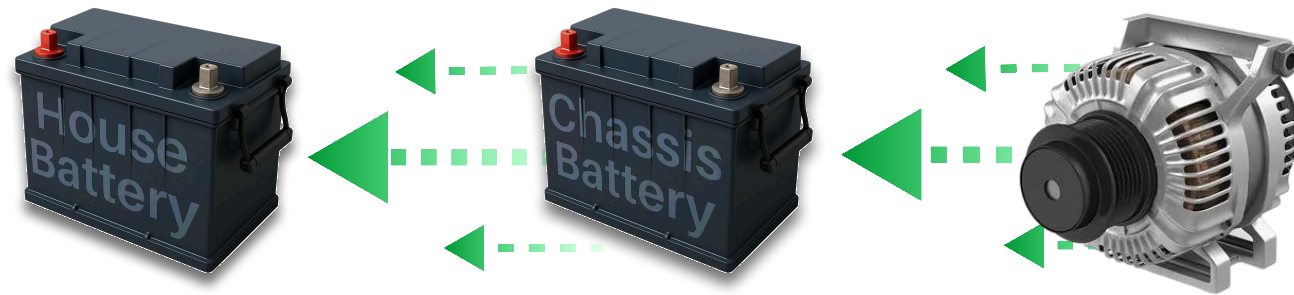

House Battery

Chassis Battery

Engine Alternator

The merge solenoid will **engage** if the following conditions are present:

- Engine run or **ignition** signal is **present** and **chassis voltage** is **above 13.3 V** (Charging) for **30 seconds**

The merge solenoid will **disengage** under either of the following conditions:

- Engine run or **ignition signal** is **removed**
- **Chassis voltage** drops **below 12.6V** for more than **30 seconds** (unmerge until engine started again)

## House Charging Chassis State

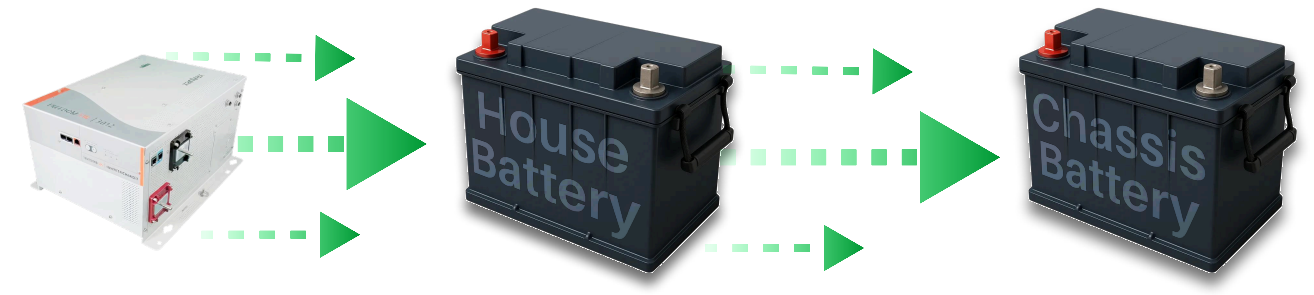

Charger or other DC  
Charging Sources

House Battery

Chassis Battery

The merge solenoid will **engage** if the following conditions are present:

- The **House Voltage** is **above 12.5V** (Charging) and **Chassis Voltage** is **below 12.4V** (low Battery Voltage) for **30 seconds**.

The merge solenoid will **disengage** under either of the following conditions:

- **House Voltage** drops **below 12.2V** for more than **30 seconds**. **OR**
- The **60 minutes** timed battery **merge** period **expires**. **Re-merge** will occur again if the merge conditions are still present.



- The **voltages** listed in this spec are **measured directly** at the **merge solenoid** located in the DCD panel. These **readings** may **differ** from the **voltages shown** on the **LCD** screens, which are provided for general reference.

# EMS Energy Management System

## What is EMS (Energy Management System)

The **EMS** (Energy Management System) is **software** that monitors how much AC power is available and how much is being used.

When **demand exceeds the supply**, it **automatically temporarily shuts off** certain **loads** to prevent tripping the shore or generator breaker.

## How Does it Work?

The EMS works by allowing or blocking AC power to specific loads. Note that not all AC loads are controlled by the EMS.

The loads that are EMS-controlled appear in the center column of the Power Page on the main hall LCD. **EMS must be enabled** for this information to be visible.

## What Does "Shed" Mean?

When the EMS disallows AC power to a load, that load is considered "shed." This simply means there isn't enough AC power available at the moment.

The EMS will **automatically** restore power to the load once sufficient power becomes available.

## What Loads Can Shed?

The following loads can **shed**:

- Dishwasher
- Clothes Washer / Dryer
- Engine Preheat
- All Air Conditioner Zones
- All Floorheat Zones
- Fireplace
- Aqua-Hot
- Aqua-Hot High (650D Only)

## The TRC Transfer Switch

The TRC transfer switch receives AC power from either the generator or the shore power pedestal.

It also reports information about the **type and quality** of that power, which is then **displayed** on the **Spyder LCD** screens inside the coach.

The Spyder system **does not** produce the AC power readings we only display the readings.

## Inverter Assist

- On rare occasions you may notice a large negative current draw on the house batteries while you are connected to shore or running the generator. This state is called **Inverter Assist**.
- Inverter assist is a state in which power is temporarily drawn from the batteries to keep EMS loads from shedding.
- If the following is **TRUE** inverter assist will activate:
  - Shore or generator power is available
  - The charger is in **Float Mode** (batteries close to full)
  - The charge rate has been reduced
  - A non-EMS inverted load is activated, such as a microwave or hair dryer.

# Generator

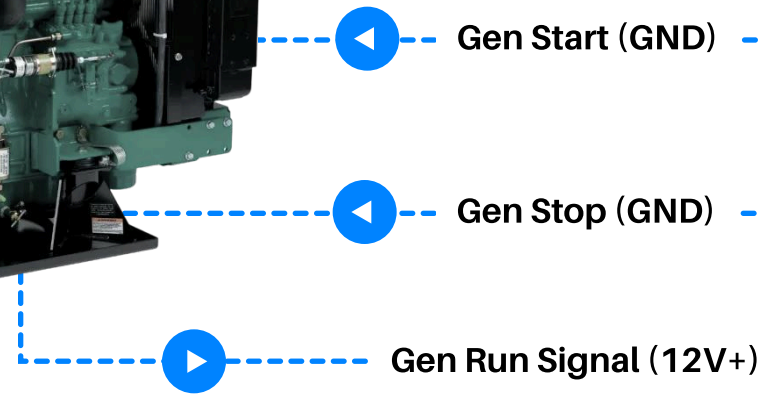
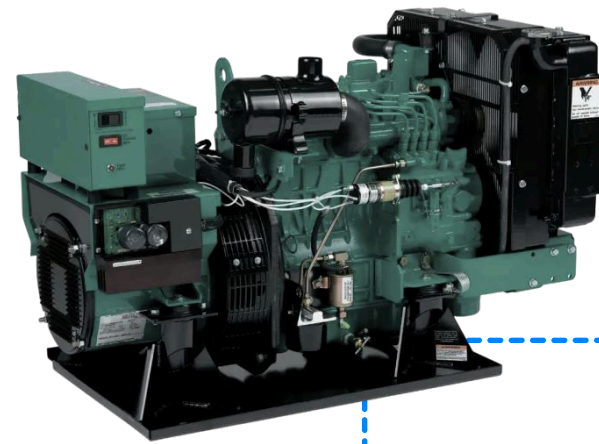

M1 Mid Panel

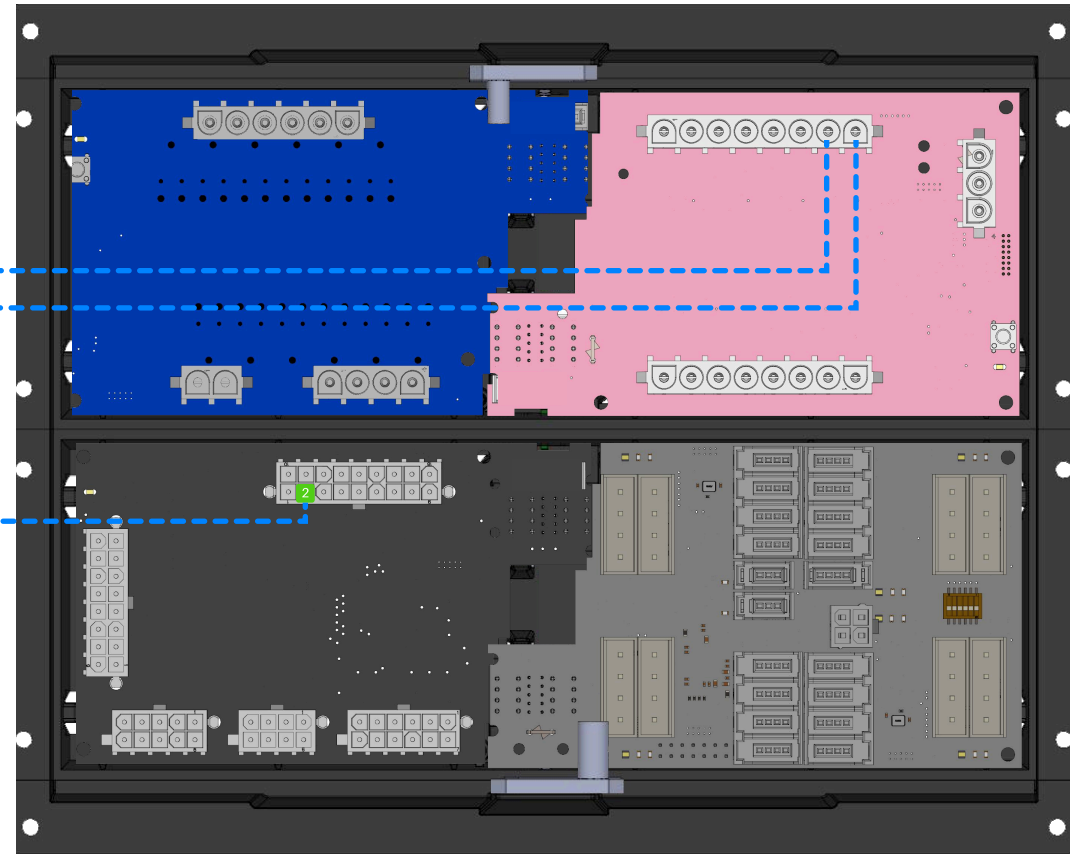

## Operating the Generator

The generator can be started by using the generator start/stop switch on the dash or by activating it from any Spyder Screen.

The AGS (Auto Generator Start) can be set to automatically toggle the generator on or off based on user defined conditions.

# DCD Panel

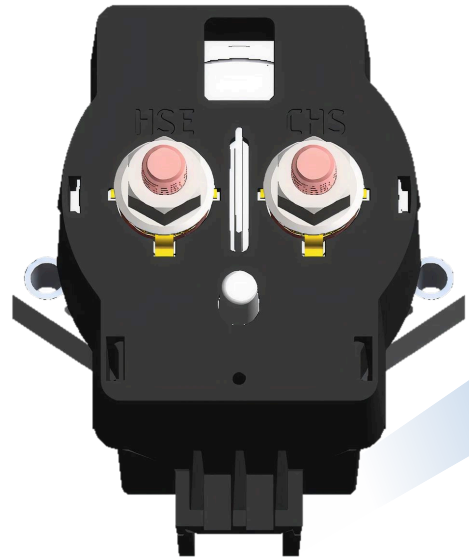

## Mergeman

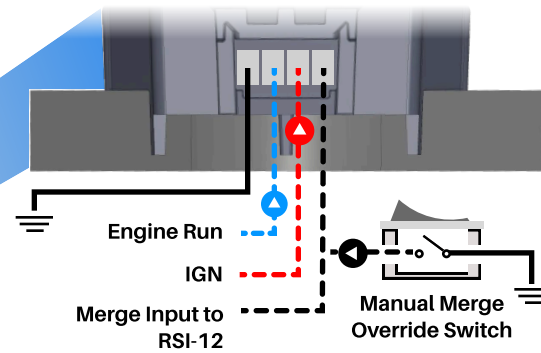

## BDC3

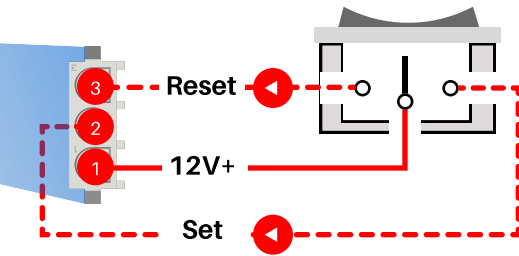

The **BDC3** module **shuts off house power** to the **Rear M1 Panel** when the battery switch is toggled at the entry way 5" panel.

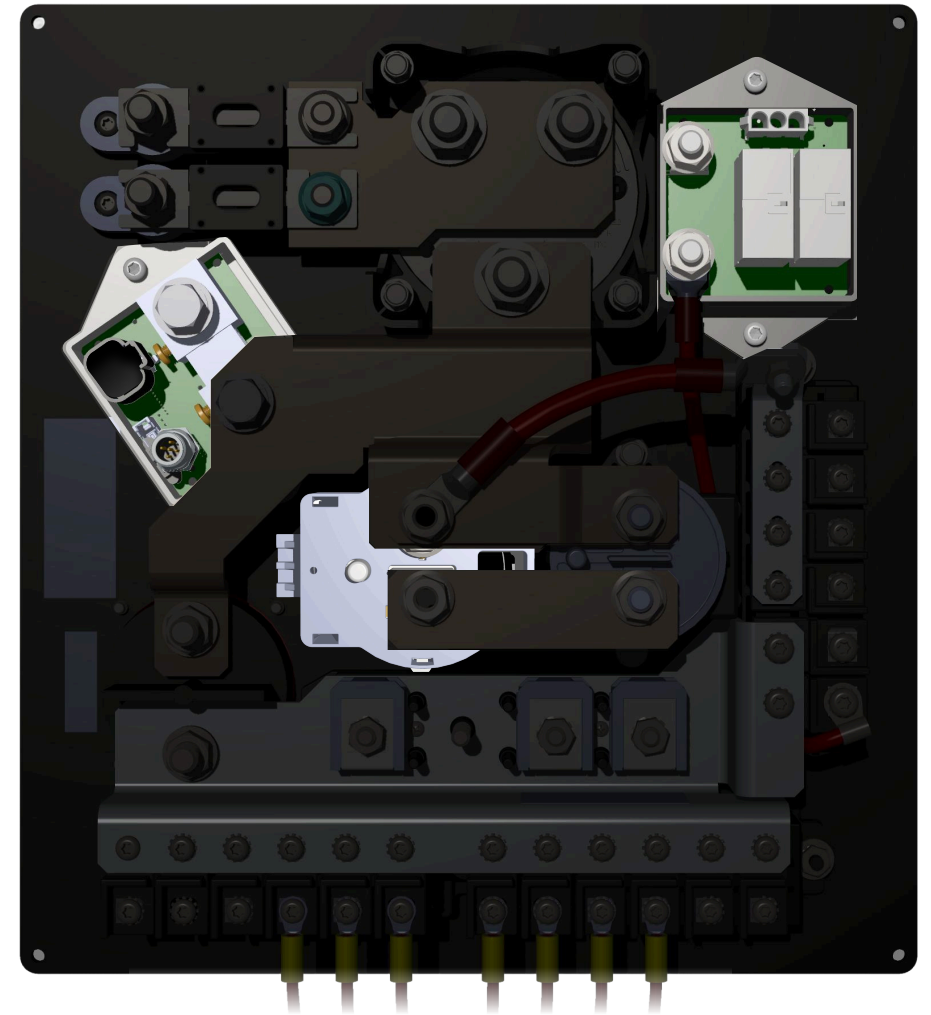

## DCD Panel

The DCD panel serves as the central hub for high-current DC power distribution. It has several compact, intelligent modules mounted to it, as shown to the left.



## Trustate Module

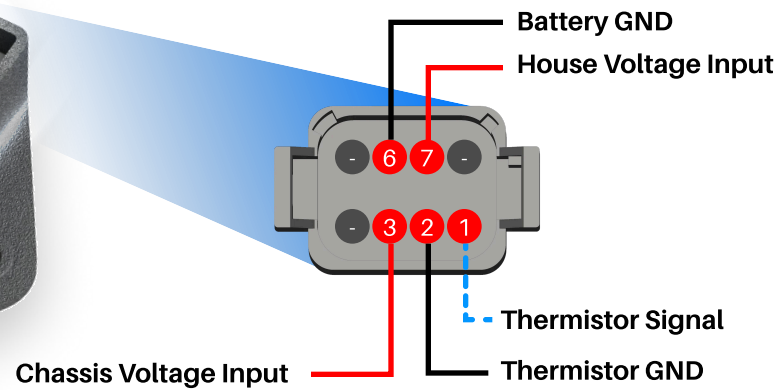

The Trustate provides the following information:

- Current in Amps (In/Out) of the House Batteries
- House battery voltage
- Chassis battery voltage
- House battery temperature

**The Trustate only provides battery information. It does not determine when or if to charge the batteries.**

<b>Trustate</b>	Spyder PN: BMODZC700TF-M0
	Tiffin PN: 5181225
<b>Batt Thermistor</b>	Spyder PN: BSPL8T4F3TF
	Tiffin PN: 5181224

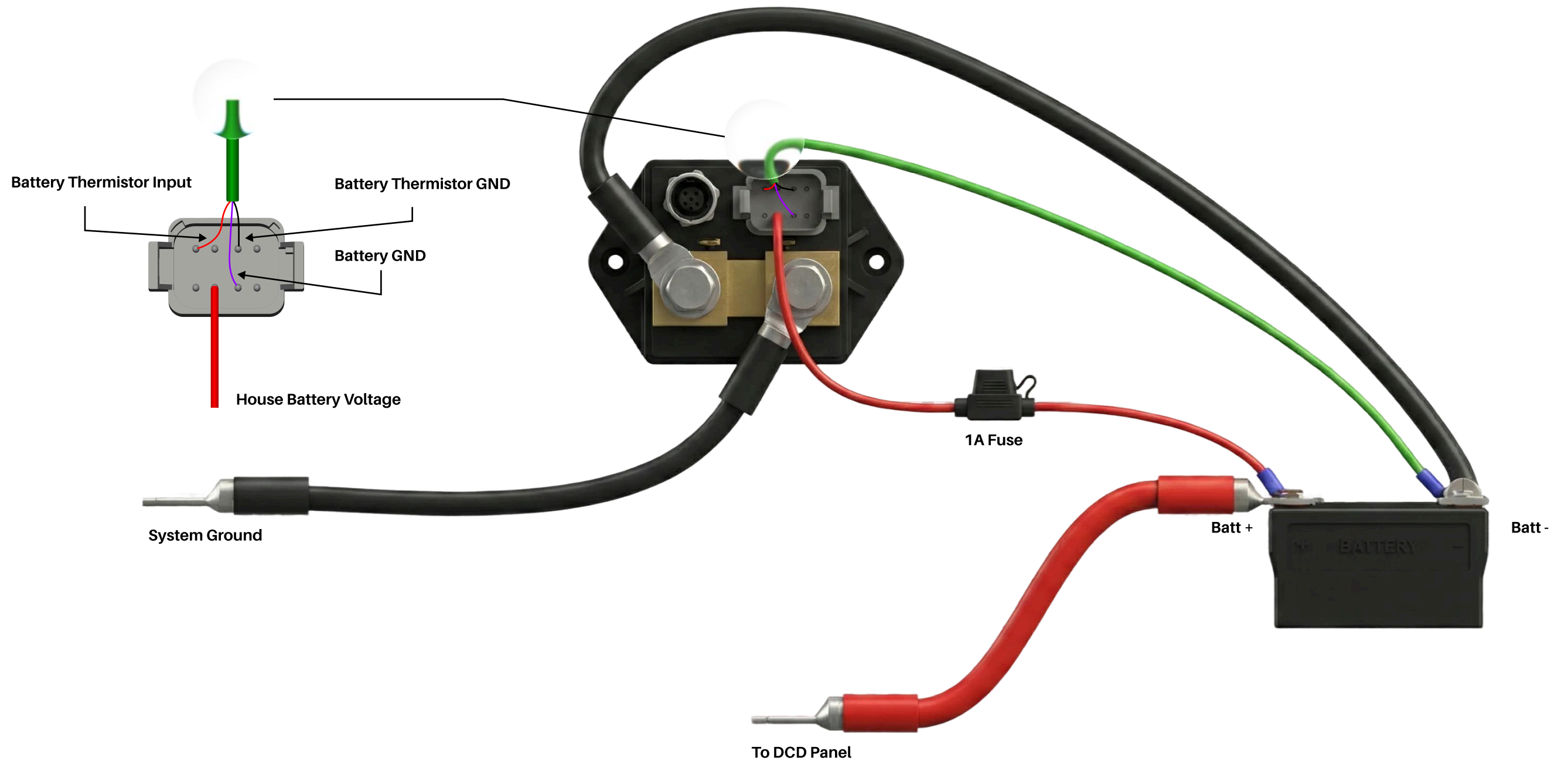

## Trustate Module

The TruState module in this coach measures battery state of charge (SoC) on the ground side of the system. All current entering or leaving the battery passes through the TruState shunt, allowing the module to accurately calculate and report battery SoC on the LCD displays. This value is shown as the battery percentage on the main hallway screen. In addition to state of charge, the TruState also monitors house battery voltage, house battery temperature, and chassis voltage.



For the TruState to operate correctly, the battery bank capacity must be configured on the main LCD screen. This setup is completed at the factory when the coach is new. If the battery bank size or battery chemistry is changed, the settings must be updated on the main LCD. To adjust these settings, navigate to: Power → Power Settings → TruState → Adjust Bank Size or Battery Type

# DCD Panel

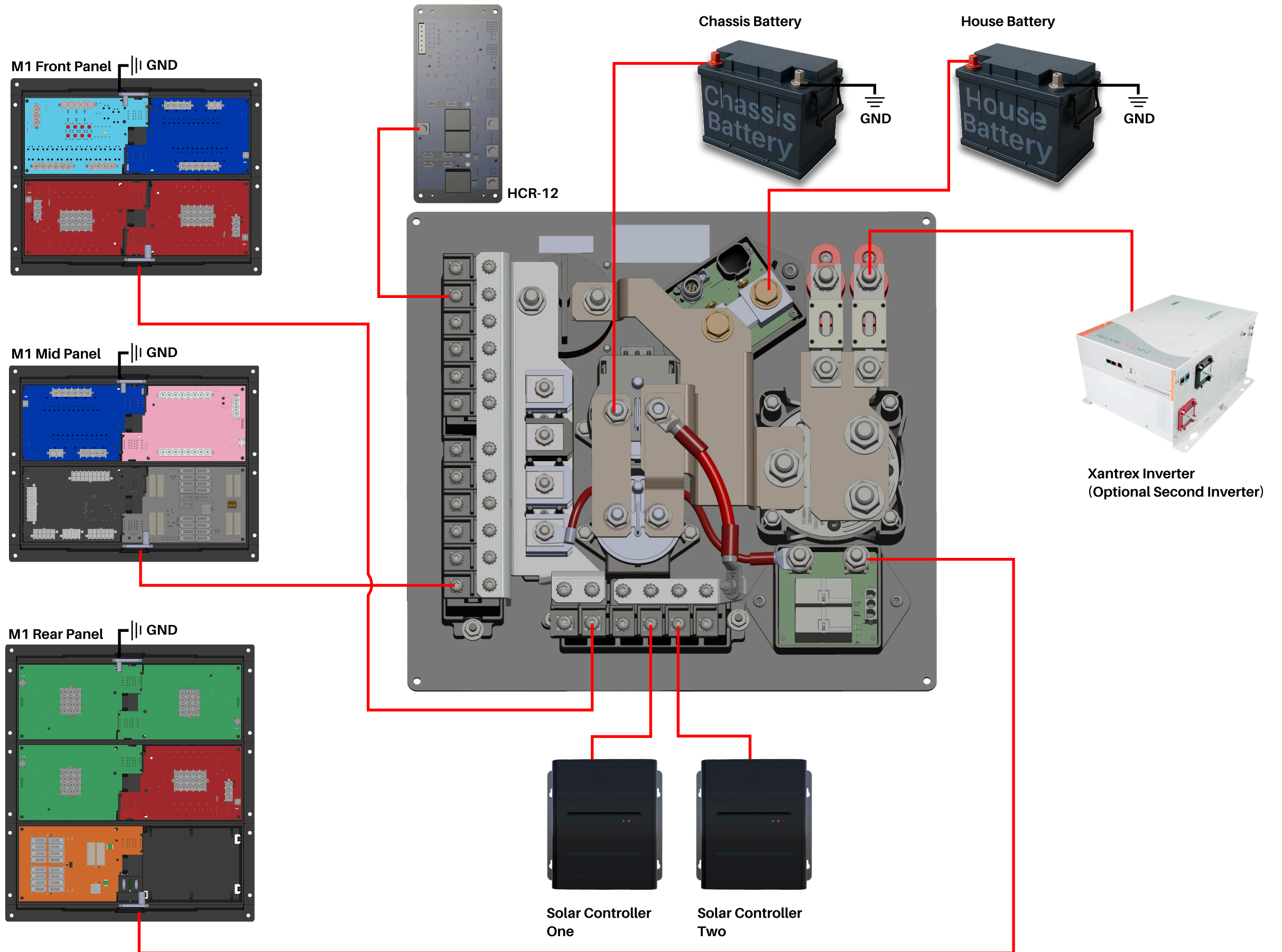

# Shade Module Power

Dash Shade Module

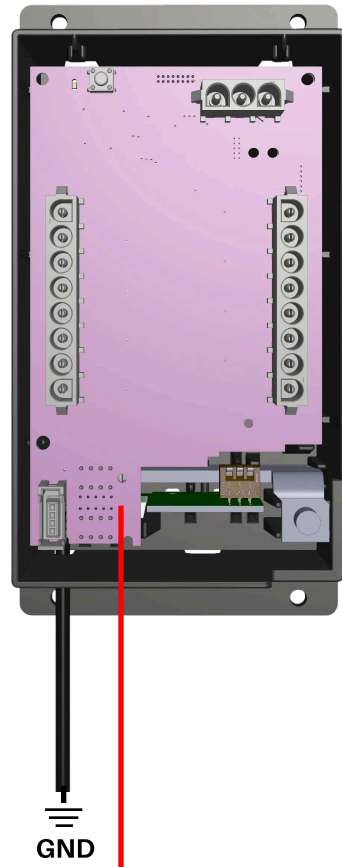

M1 Front Panel

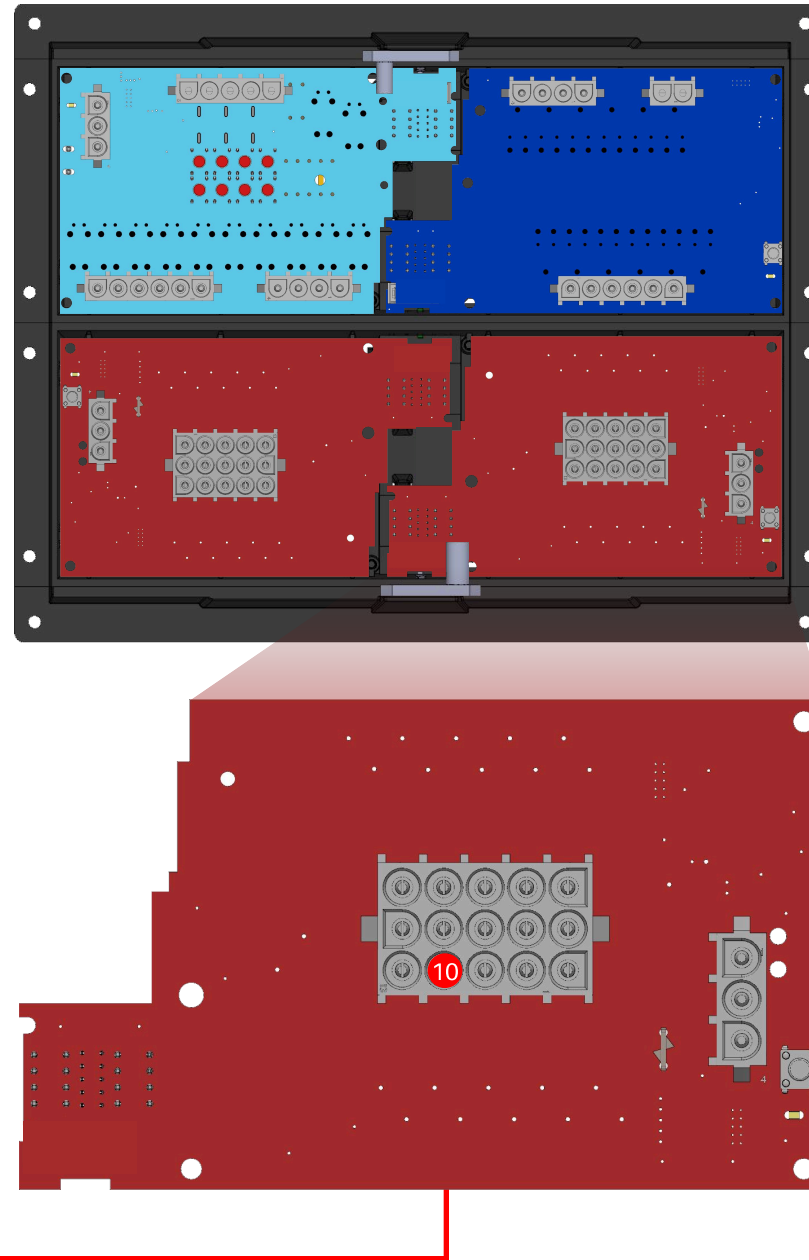

# Spyder Network

# CAN Router

## Networks Overview

### Yellow - Always On

The orange network is powered on even when the battery disconnect switch at the entry door is off.

### Blue - Critical Network

The blue network contains critical items like A/C units, rear M1 panel, hall LCD, ACR3.

### Orange - Switches

The yellow network is primarily the switch and screen network where most LCDs connect too.

### NET 5 (Not Actually Pink)

NET 5 shown in pink only for visual purposes connects to the Xantrex Inverter.

### NET 6 (Not Actually Green)

NET 6 shown in green only for visual purposes connects to the Valid Glass Dash.

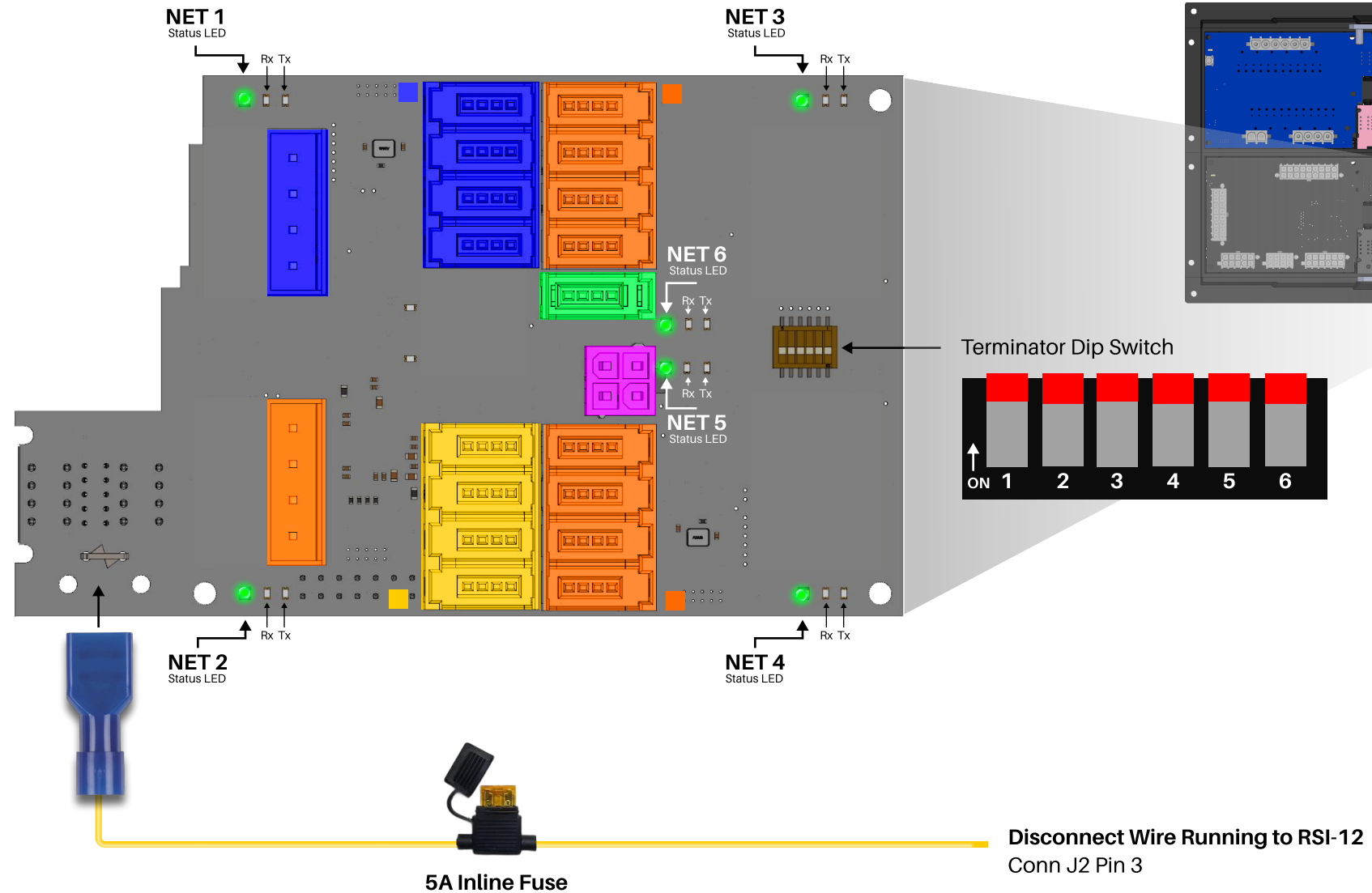

## Network LEDs

- **Solid Green**  
Device is connected to network and communicating properly.
- **LED Off**  
Device has no power or has failed completely.
- **Solid Red LED**  
Device has gone offline and is not connected to the network

- **Fast Flashing Green (1 times / sec)**  
Device is connected to network and communicating properly.
- **Slow Flashing Green (4 times / sec)**  
Device is connected to network and communicating properly.
- **Alternating Red / Orange**  
Device is connected to network and communicating properly.

- **Alternating Green / Orange**  
Device is connected to network and communicating properly.

### Understanding NET LEDs

This LED provides a quick, at-a-glance indication of that device's network status. By looking at the NET LEDs on multiple devices, you can assess the overall network health.

For example:

- If all NET LEDs are green, the network is healthy.
- If all NET LEDs are red, the network is not healthy and there is a communication issue.

# Blue Network

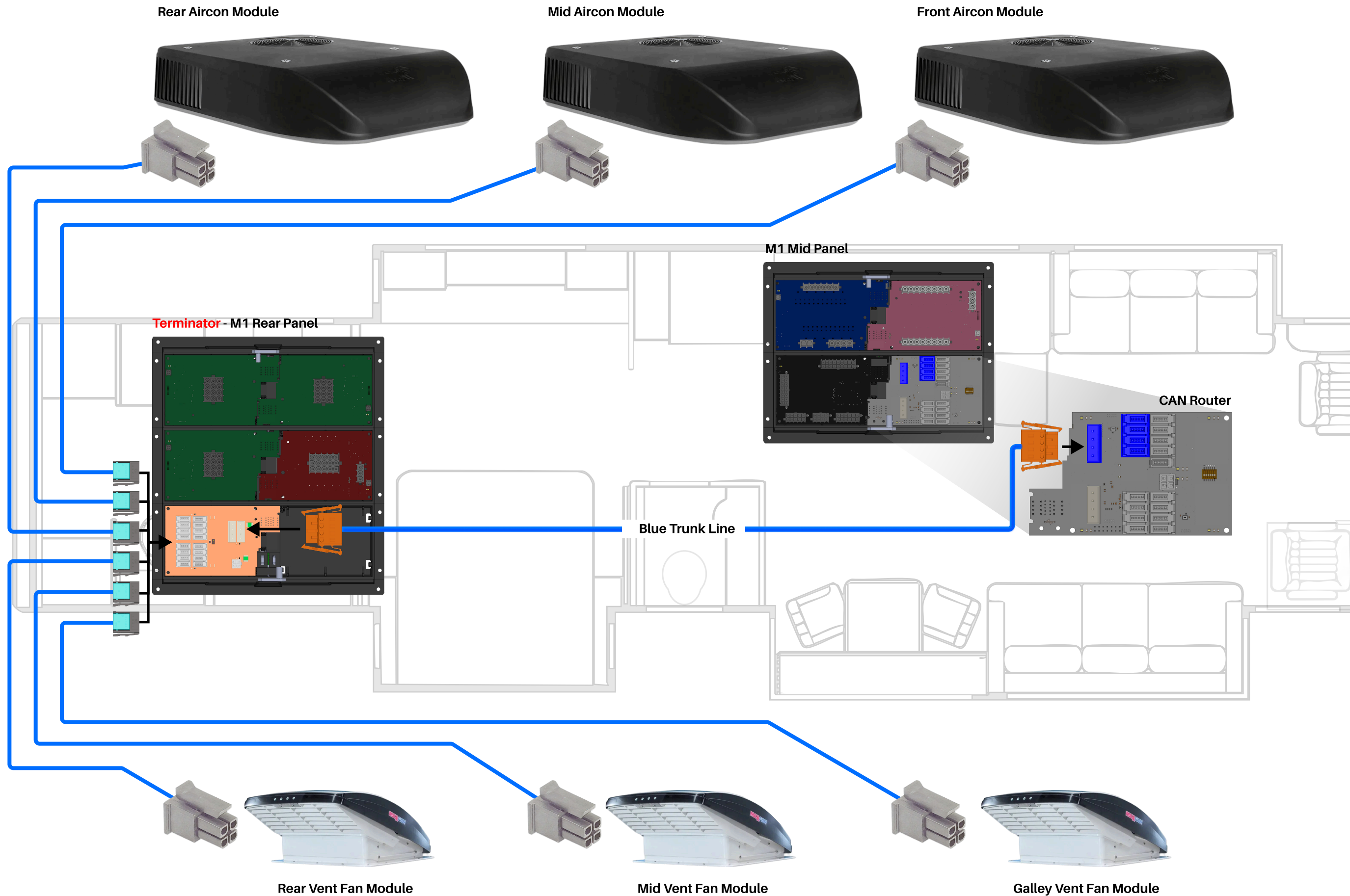

# Blue Network

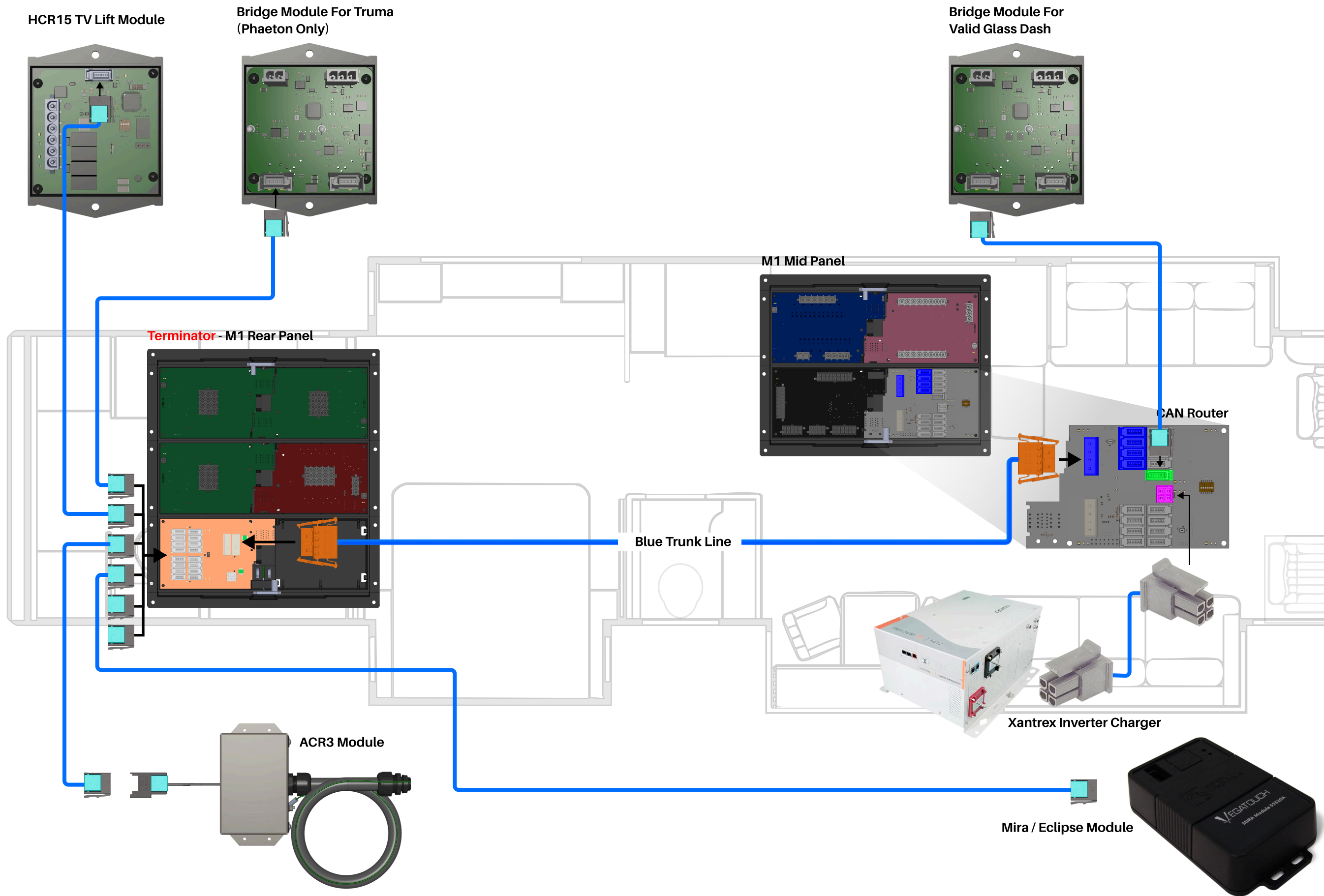

# Yellow Network

M1 Mid Panel

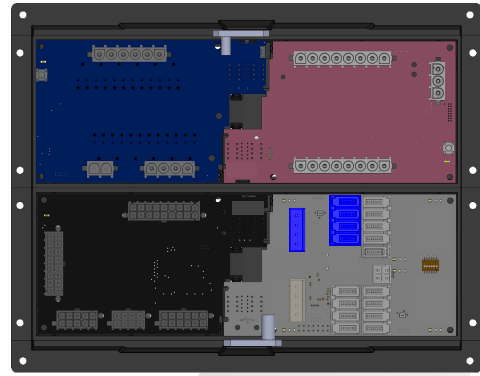

M1 Mid Panel



Terminator - HCR-11 Drop Tap

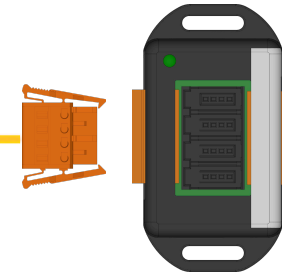
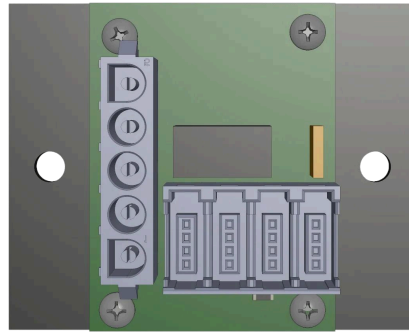

CAN Router

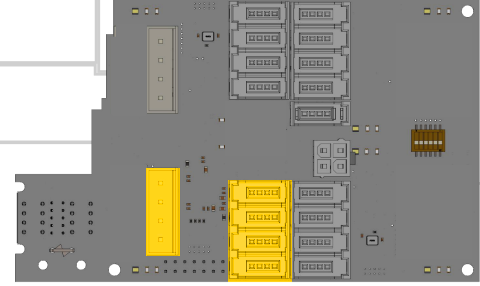

RF Hub



G4 Common Tap

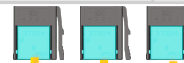

D/S Console SSP25



Dash SSP25

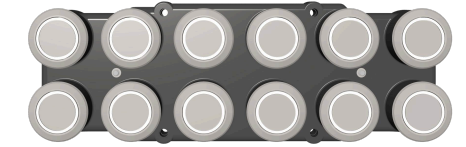

M1 Dash Module

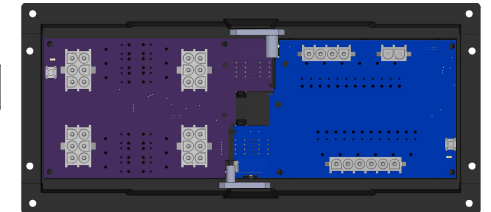

Dash Shade Module

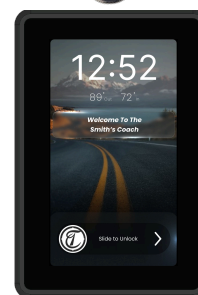
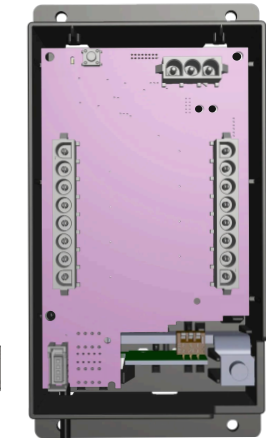

Exterior 5"

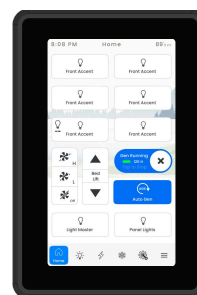

Passenger 5"

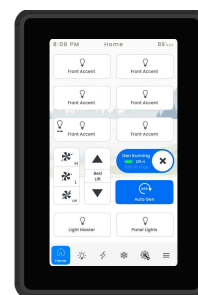

Entry 5"

# Orange Network

M1 Mid Panel

SeeLevel Tank Monitor

Aqua-Hot

Solar Controller One

Solar Controller Two

TRC Transfer Switch

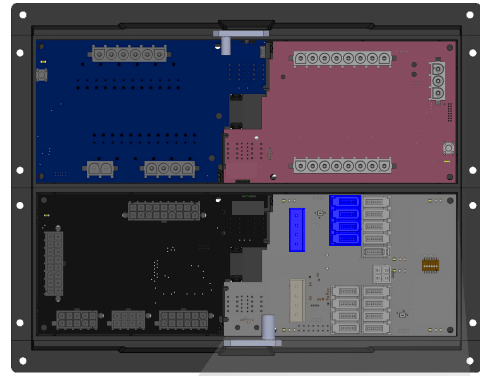

CAN Router

Galley 3.5"

G4 Common Tap

Mid Bath 3.5"

G4 Terminator

Rear Bath 3.5"

Dinette 3.5"

Bed 5"

Bed 5"

G4 Terminator

# Always On



• THE NETWORK CABLES INSERTED INTO THIS DROP TAP MUST BE IN ORDER. THE ITEMS ON THE RIGHT ARE ALWAYS ON. THE ITEMS ON THE LEFT TURN OFF WHEN THE BATTERY DISCONNECT IS TOGGLED. SWAPPING THE NETWORK CABLES AT THIS TAP WILL CAUSE ISSUES.

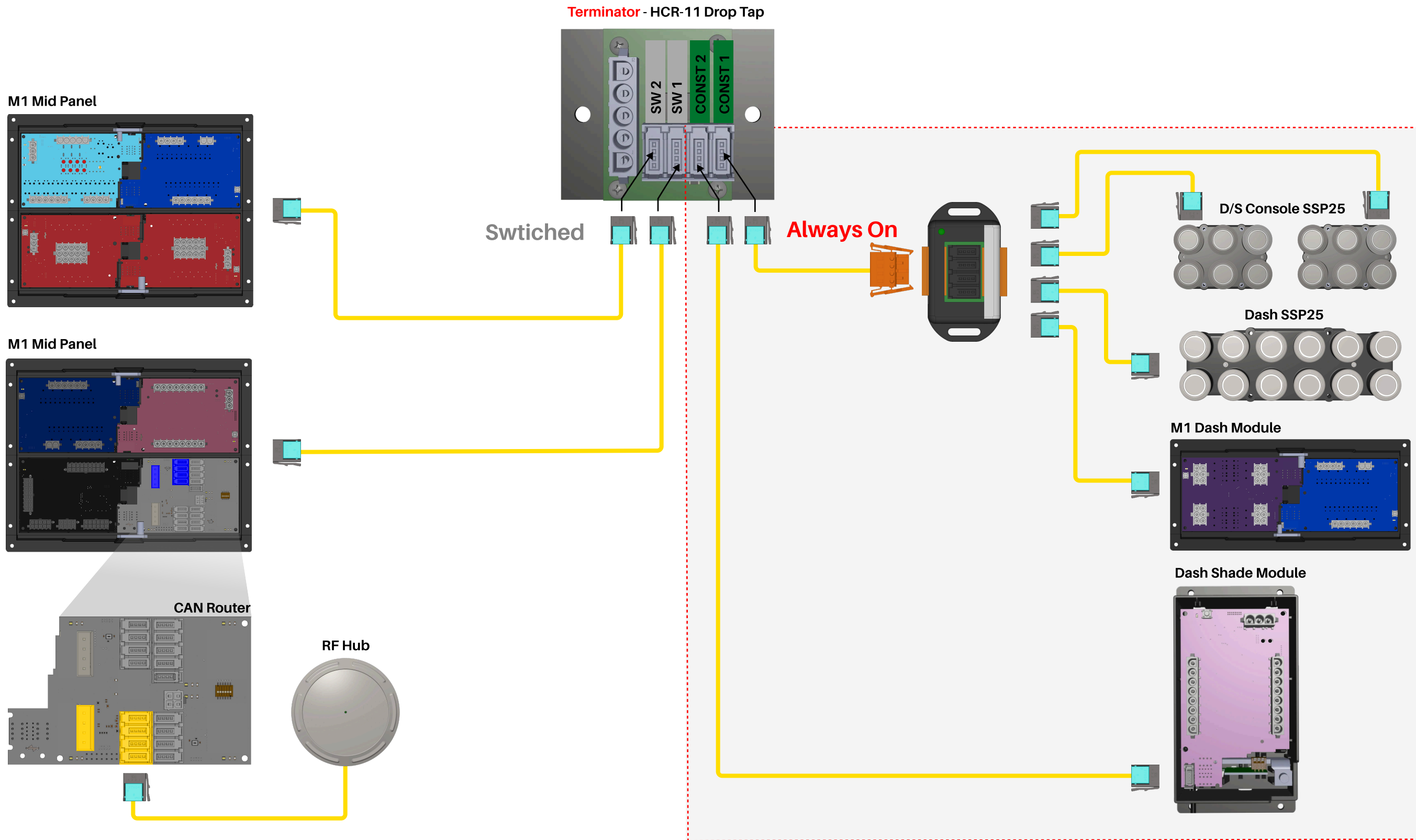

## **Additional Information**

# Connectors

Connectors		
 <p><b>Male Network End</b> Spyder P/N: CON824204 Tiffin P/N: 5066157 Manufacturer P/N: 37104-2165-000 FL 100</p>	 <p><b>12 Pos - Mini Fit Jr Connector</b> Manufacturer P/N: 770581-1 <b>Matching Pin (16-20 AWG)</b> Manufacturer P/N: 171639-1</p>	 <p><b>3 Pos - Mate-N-Lok Connector</b> Manufacturer P/N: 350766-1 <b>Matching Pin (14-20 AWG)</b> Manufacturer P/N: 350550-1</p>
 <p><b>Female Network End</b> Spyder P/N: CON824204 Tiffin P/N: 5066157 Manufacturer P/N: 37104-2165-000 FL 100</p>	 <p><b>16 Pos - Mini Fit Jr Connector</b> Manufacturer P/N: 770583-1 <b>Matching Pin (16-20 AWG)</b> Manufacturer P/N: 171639-1</p>	 <p><b>4 Pos - Mate-N-Lok Connector</b> Manufacturer P/N: 350779-1 <b>Matching Pin (14-20 AWG)</b> Manufacturer P/N: 350550-1</p>
 <p><b>4 Pos - Mini Fit Jr Connector</b> Manufacturer P/N: 0039013042 <b>Matching Pin (18-24 AWG)</b> Manufacturer P/N: 0039000039</p>	 <p><b>18 Pos - Mini Fit Jr Connector</b> Manufacturer P/N: 770584-1 <b>Matching Pin (16-20 AWG)</b> Manufacturer P/N: 171639-1</p>	 <p><b>5 Pos - Mate-N-Lok Connector</b> Manufacturer P/N: 643406-1 <b>Matching Pin (14-20 AWG)</b> Manufacturer P/N: 350550-1</p>
 <p><b>8 Pos - Mini Fit Jr Connector</b> Manufacturer P/N: 770579-1 <b>Matching Pin (16-20 AWG)</b> Manufacturer P/N: 171639-1</p>	 <p><b>2 Pos - Mate-N-Lok Connector</b> Manufacturer P/N: 350777-1 <b>Matching Pin (14-20 AWG)</b> Manufacturer P/N: 350550-1</p>	 <p><b>6 Pos - Mate-N-Lok Connector</b> Manufacturer P/N: 640581-1 <b>Matching Pin (14-20 AWG)</b> Manufacturer P/N: 350550-1</p>
 <p><b>10 Pos - Mini Fit Jr Connector</b> Manufacturer P/N: 770580-1 <b>Matching Pin (16-20 AWG)</b> Manufacturer P/N: 171639-1</p>	 <p><b>2 Pos - Mate-N-Lok Connector</b> Manufacturer P/N: 350777-1 <b>Matching Pin (14-20 AWG)</b> Manufacturer P/N: 350550-1</p>	 <p><b>8 Pos - Mate-N-Lok Connector</b> Manufacturer P/N: 640582-1 <b>Matching Pin (14-20 AWG)</b> Manufacturer P/N: 350550-1</p>

## Important Contact Information

• If this document has been printed the numbers, emails, and websites may be out of date.

Spyder Controls Corp: [info@spydercontrols.com](mailto:info@spydercontrols.com) - [www.spydercontrols.com](http://www.spydercontrols.com) - 866-919-9092

Firefly integrations (Mobile App): [support@fireflyint.com](mailto:support@fireflyint.com) - [www.fireflyint.com](http://www.fireflyint.com) - 574-825-4600

Tiffin Service: [www.tiffinmotorhomes.com](http://www.tiffinmotorhomes.com) - 256-356-0261

Dometic (Solar Controllers): [dometic.com](http://dometic.com) - 1-800-544-4881

Aqua-Hot (Water Heater): [www.aquahot.com](http://www.aquahot.com) - 574-247-9235











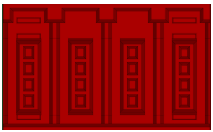

Garnet Industries (SeeLevel Tank Sensors): [www.garnetinstruments.com](http://www.garnetinstruments.com) - 1-800-617-7384

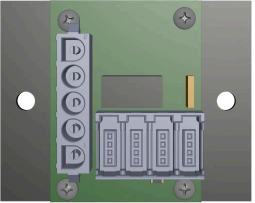
Xantrex (Inverter/Charger): [www.xantrex.com](http://www.xantrex.com) - 1-800-670-0707

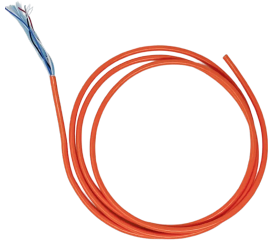
Valid Manufacturing (Glass Dash): [validmfg.com](http://validmfg.com) - 1-888-632-6477 - **24HR Service** 250-804-1247

Airxcel (Ventfan / AC Units): [Airxcel.com](http://Airxcel.com) - 574-247-9235

# Connectors & Tools

Connectors		
 <p><b>6 Pos - Mate-N-Lok Connector</b>            Manufacturer P/N: 1-480704-0  <b>Matching Pin (14-20 AWG)</b>            Manufacturer P/N: 350550-1</p>	 <p><b>Wago Connector</b>            Tiffin P/N: 5015508            Manufacturer P/N: 231-304/037-000</p>	 <p><b>G4 Terminator Drop Tap</b>            Spyder P/N: BBCKZK400            Tiffin P/N: 5051936</p>
 <p><b>12 Pos - Mate-N-Lok Connector</b>            Manufacturer P/N: 1-480708-0  <b>Matching Pin (14-20 AWG)</b>            Manufacturer P/N: 350550-1</p>	 <p><b>Wago Hook Tool</b>            Manufacturer P/N: 231-131</p>	 <p><b>Terminator - HCR-11 Drop Tap</b>            Spyder P/N: BMODZGAN6-1            Tiffin P/N: 5131310</p>
 <p><b>15 Pos - Mate-N-Lok Connector</b>            Manufacturer P/N: 350736-1  <b>Matching Pin (14-20 AWG)</b>            Manufacturer P/N: 350550-1</p>	 <p><b>RV-C Cable (By FT)</b>            Tiffin P/N: 5064775</p>	<p><b>How To Properly Crimp RV-C Network Ends Video</b></p>  <p>Scan with phone camera</p>
 <p><b>Mate-N-Lok Pin Extractor</b>            Manufacturer P/N: 305183</p>	 <p><b>RV-C Cable (20ft W/ MALE ENDS)</b>            Spyder P/N: BSPLZL200-20</p>	
 <p><b>Mini Mate-N-Lok Pin Extractor</b>            Manufacturer P/N: 189727-1</p>	 <p><b>G4 Common Drop Tap</b>            Spyder P/N: BBCKZK200            Tiffin P/N: 5016592</p>	

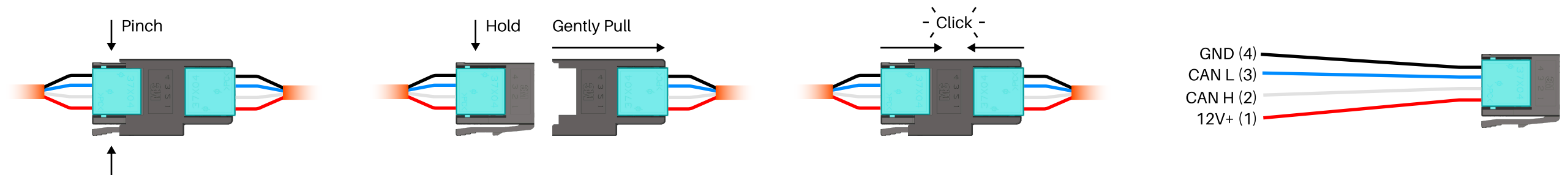

**SPYDER**  
CONTROLS CORP