

The Adventure Starts Now. Explore. Find Out. Live. Free.

# 2026

## Tiffin Allegro RED / Bay

Integration Schematic



SPYDER



1

Module Locations



2

Module Locations Cont.



3

G12 Pinout



4

G12 Pinout (Continued)



5

M1 Overview



6

M1 Slide Card



7

M1 Slide Card Alternate



8

M1 HC Relay Card



9

M1 Breaker Card 1



10

M1 Breaker Card 2



11

Lighting



12

Slides



13

MaxxFans



14

Vent Fans (Non Maxxfan)



15

Tank Sensing



16

LPG + Chassis Voltage

## Schematic Connections Legend



Constant Ground



Constant 12V+



Switched Ground



Switched 12V+



Reverse Polarity



Signal



120V AC Line



Network

<b>17</b>	HVAC
<b>18</b>	Water Heat (Non-Truma)
<b>19</b>	Truma Water Heat
<b>20</b>	Merge System
<b>21</b>	AGS
<b>22</b>	HCR-11 Pinout
<b>23</b>	Merge Logic
<b>24</b>	Network

<b>25</b>	Network (Continued)
<b>26</b>	Power Diagram
<b>27</b>	Connectors

Schematic Connections Legend

	Constant Ground
	Constant 12V+
	Switched Ground
	Switched 12V+
	Reverse Polarity
	Signal
	120V AC Line
	Network

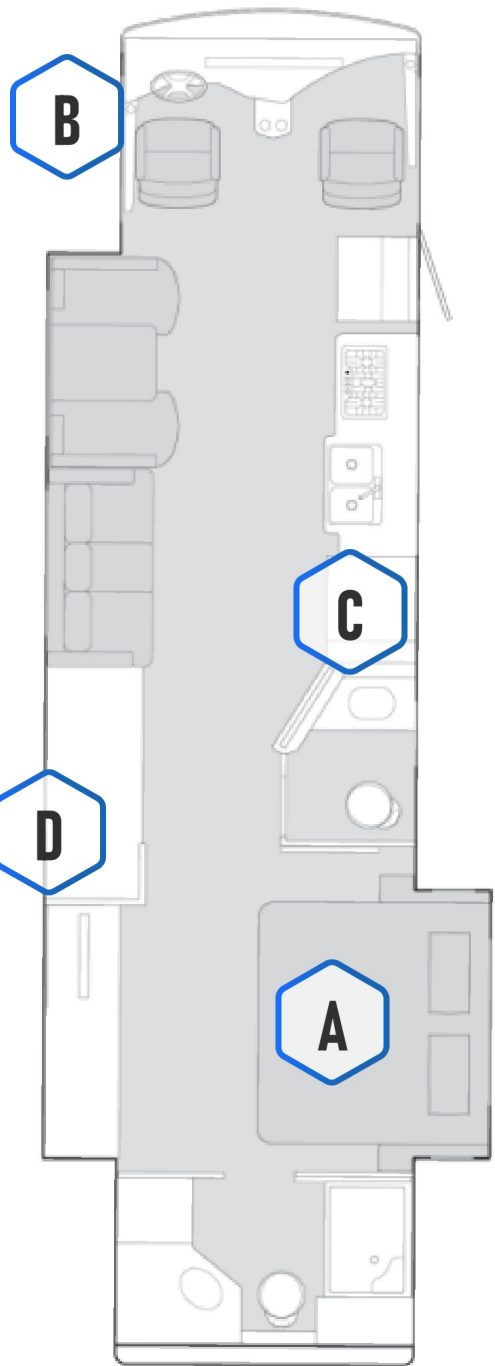

**A** **G12 Module**

**Spyder Part #**  
BMODZU2VU

**Tiffin Part #**  
5126984

**Dimensions**  
9" X 6"

**NET LED**

**NET PORTS**

A photograph of the G12 Module, a black rectangular electronic control unit. It features several terminal blocks and a green LED indicator. A blue line points from the 'NET LED' label to the green LED. Another blue line points from the 'NET PORTS' label to a row of ports at the bottom.

**B** **M1 Front Panel**

**Spyder Part #**  
BENCZM2DS

**Tiffin Part #**  
5126983

**Dimensions**  
10" X 7.8"

A photograph of the M1 Front Panel, a black rectangular control panel. It has a red section at the bottom and a cyan/blue section at the top. The cyan section contains several buttons and indicators.

**C** **7" Pro LCD**

**Spyder Part #**  
BSSPZZXXX

**Dimensions**  
7.6" X 5"

A photograph of the 7" Pro LCD screen, a black rectangular display unit.

**D** **DCD Panel**

**Spyder Part #**  
BENCZ38DR

**Tiffin Part #**  
5127283

**Dimensions**  
10" X 4"

**BREAKER LEGEND**

- 13 HOUSE DISCONNECT LOAD
- 14 FRONT FURNACE
- 15 REAR FURNACE
- 16 WASH/WATER TOILET
- 17 HOLD/PROTECT PUMP
- 18 PORCH/awning
- 19 COOL/FREIGHT FAN
- 20 SPRINK
- 21 COOLING TV
- 22 COORD REEL
- 23 SOLAR PWT
- 24 ENTRY STEP
- 25 SHIRT
- 26 M1 FRONT PANEL
- 27 HOUSE NON-DISCONNECT LOAD
- 28 SOLAR
- 29 CHASSIS LOADS
- 30 TECH/AREA
- 31 DASH EQUIPMENT
- 32 CHASSIS/FAN

**HOUSE BATTERY MASTER SWITCH**

**TIFFIN MOTORPOWER**

A photograph of the DCD Panel, a black rectangular control panel. It features a breaker legend with 18 numbered items, a red master switch for the house battery, and a silver master switch for the inverter. The Tiffin Motorpower logo is at the bottom right.

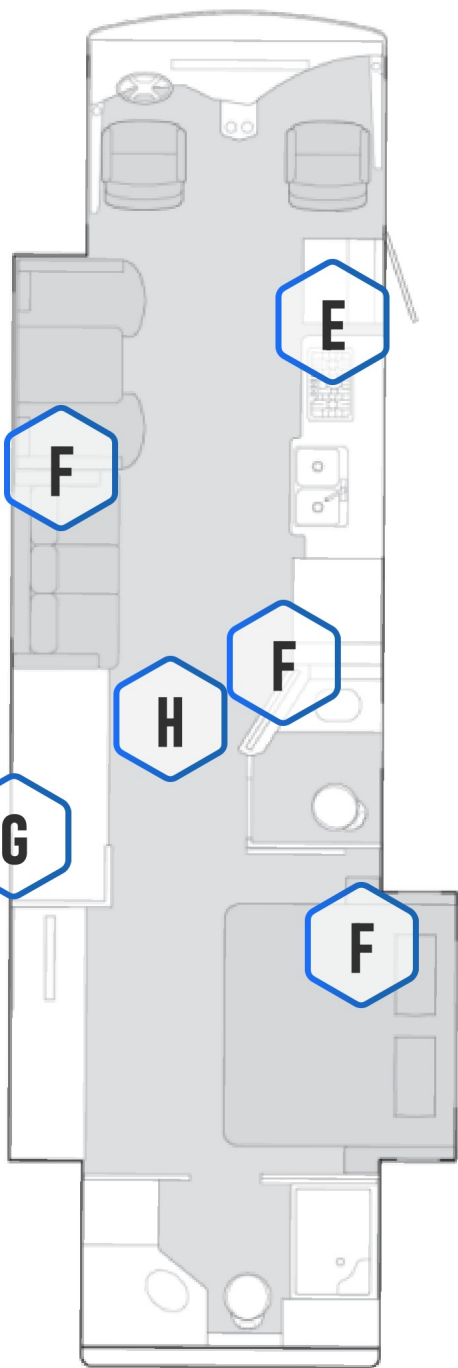

**5" Color LCD**



**Spyder Part #**  
BSSPZZREK

**Dimensions**  
5.7" X 3.6"

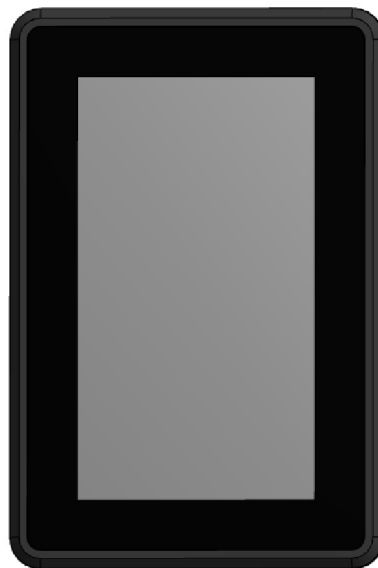

**3.5" Color LCD**



**Spyder Part #**  
BSSPZZTED

**Dimensions**  
4.5" X 2.9"

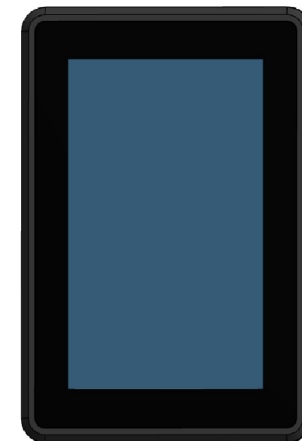

**TruState Module**



**Spyder Part #**  
BMODWC600

**Tiffin Part #**  
5114016

**Dimensions**  
2.7" X 2.7"

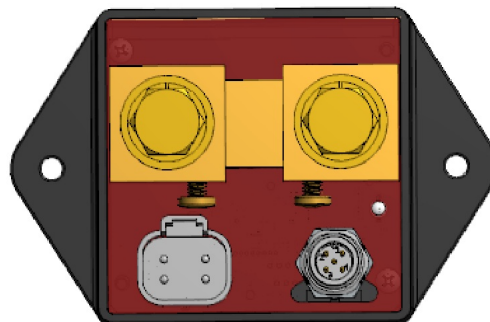

**RF Hub**



**Spyder Part #**  
BMODZRFT0

**Tiffin Part #**  
5127293

**Dimensions**  
5.1" DIA



## G12 Module @ Under Bed

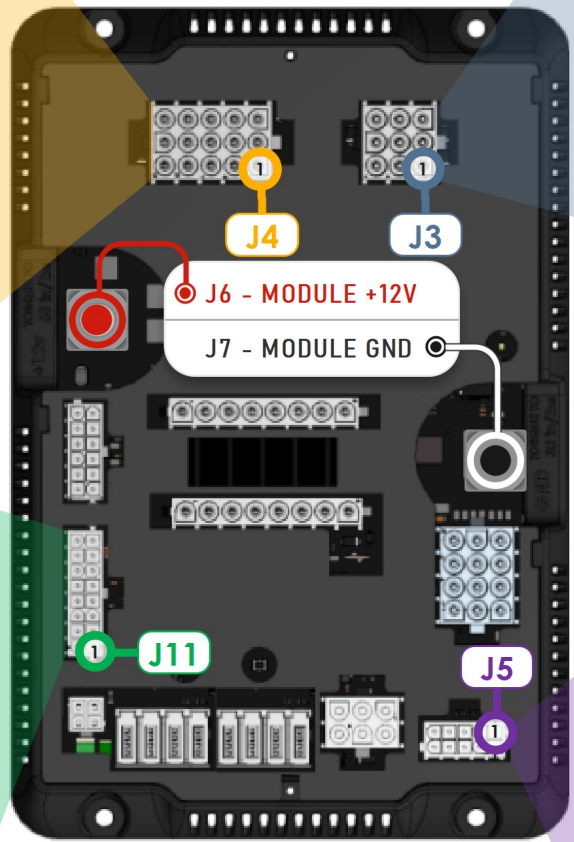

### J4

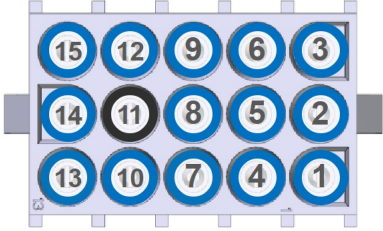

① PS Slide Lt (CH30)	⑨ RR Bath Ceiling Lt (CH38)
② DS Slide LT (CH31)	⑩ Mid Bath Ceiling Lt (CH39)
③ Living Room Lt (CH32)	⑪ Spare
④ TV Accent (CH33)	⑫ Spare
⑤ Entry Lt (CH34)	⑬ Sconce Lt (CH42)
⑥ Task Lt (CH35)	⑭ Front Accent Lt (CH43)
⑦ Hall LT (CH36)	⑮ Galley (CH44)
⑧ Bed Ceiling Lt (CH37)	

### J3

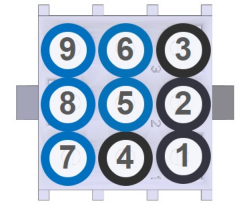

① Spare	⑥ Ceiling Fan Lo (CH26)
② Spare	⑦ Galley Fan (CH27)
③ Spare	⑧ Mid Bath Fan (CH28)
④ Sofa Reading Lt	⑨ Rear Bath Fan (CH29)
⑤ Ceiling Fan Hi (CH25)	

### J11

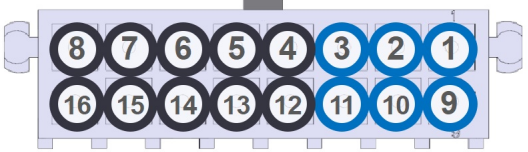

① Fresh Tank Sensor Input	⑨ Tank Sensor GND
② Grey Tank Sensor Input	⑩ Tank Sensor GND
③ Black Tank Sensor Input	⑪ Tank Sensor GND
④ Spare	⑫ Spare
⑤ Spare	⑬ Spare
⑥ Spare	⑭ Spare
⑦ Spare	⑮ Spare
⑧ Spare	⑯ Spare

### J5

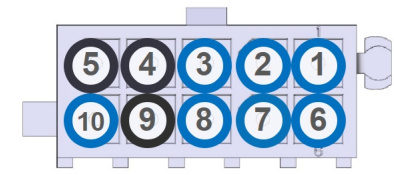

① Park Brake (GND)	⑥ IGN Input (+12V)
② WTR Pump SW (GND)	⑦ Spare (+12V)
③ Entry Door Pin Sw (GND)	⑧ Shore PWR Detect. (+12V)
④ Merge Status (GND)	⑨ Water Heater Status (+12V)
⑤ Spare (GND)	⑩ Spare (+12V)

## J12

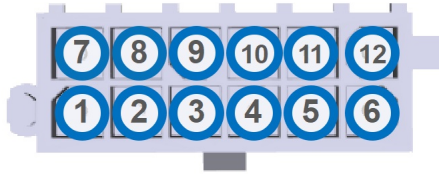

① FR Floor Therm	⑦ FR Floor Therm GND
② RR Floor Therm	⑧ RR Floor Therm GND
③ Front AC Therm	⑨ Front AC Therm GND
④ Mid AC Therm	⑩ Mid AC Therm GND
⑤ Rear AC Therm	⑪ Rear AC Therm GND
⑥ Bay Therm	⑫ Bay Therm GND

## G12 Module @ Under Bed

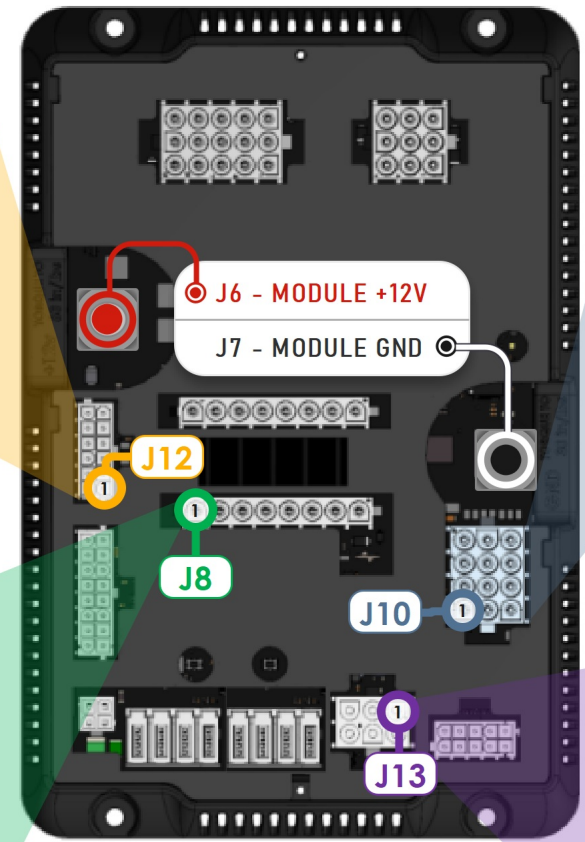

## J10

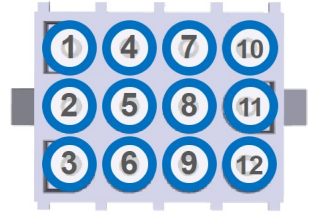

① FR A/C Comp	⑦ MID A/C Fan LO
② FR A/C Fan HI	⑧ MID A/C Ht Pump
③ FR A/C Fan LO	⑨ RR A/C Comp
④ FR A/C Ht Pump	⑩ RR A/C Fan HI
⑤ MID A/C Comp	⑪ RR A/C Fan LO
⑥ MID A/C Fan Hi	⑫ RR A/C Ht Pump

## J8



① Galley Fan Lid Up	⑤ Rear Bath Fan Lid Up
② Galley Fan Lid Dn	⑥ Rear Bath Fan Lid Dn
③ Mid Bath Fan Lid Up	⑦ Front Furnace
④ Mid Bath Fan Lid Dn	⑧ Rear Furnace

## J13

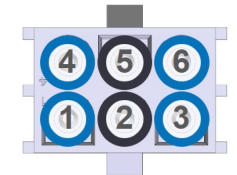

① LPG Sig	④ LPG GND
② Spare	⑤ Spare
③ Spare	⑥ Gen Run Status

## M1 Slide Card

- Awning Constant
- Undercoach Constant
- Slide Breaker #1
- Slide Breaker #2
- Slide Breaker #3
- Ignition (12V)
- Park Brake (GND)
- P/S FR Slide EXT
- P/S FR Slide RET
- D/S FR Slide EXT
- D/S FR Slide RET
- P/S RR Slide EXT
- P/S RR Slide RET
- D/S RR Slide EXT
- D/S RR Slide RET
- Hydraulic Pump

## M1 Breaker (Card 3)

- Camera/Radio (IGN)
- Jack Buzzer (IGN)
- CB/Satellite
- Panel Lamp/Head LT (IGN)
- 12V Outlet 1/USB PWR
- Euro Loft (IGN)
- TV Relay/Fridge/Dash SHD MOD (IGN)
- HVAC Denso (IGN)
- Dock Light
- Entry Step SW
- IGN (+12V)

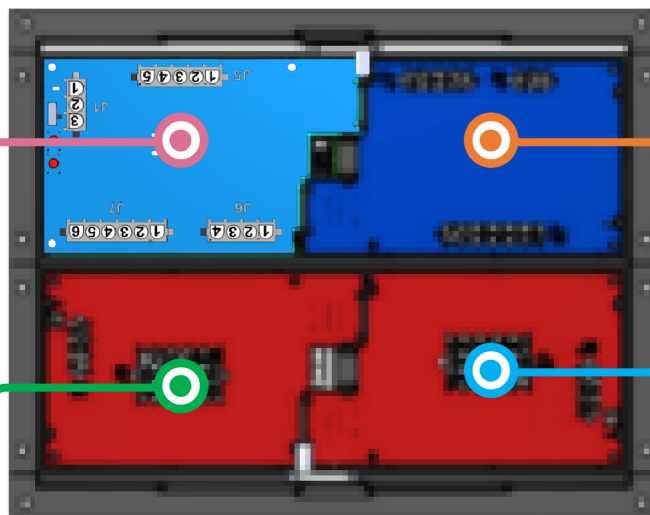
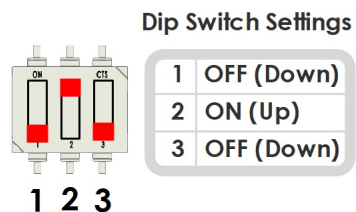

M1 Front Panel

## M1 HC Relay Card

- Door/Assist Handle
- Water Pump
- Porch
- Entry Door Lock
- Entry Door Unlock
- Door Awning EXT
- Door Awning RET
- Gen Start (GND)
- Gen Stop (GND)

## M1 Breaker (Card 4)

- HVAC Denso
- 12V Outlet 2/ USB PWR
- Engine Preheat SW
- Electric Step Cover
- Power Window (IGN)
- D/S Mirror PWR (IGN)
- P/S Mirror PWR (IGN)
- Seat Power #1
- Seat Power #2
- Cargo Lights
- Map Lt/Fans/Radio
- Truma
- IGN (12V)

## M1 Front Panel

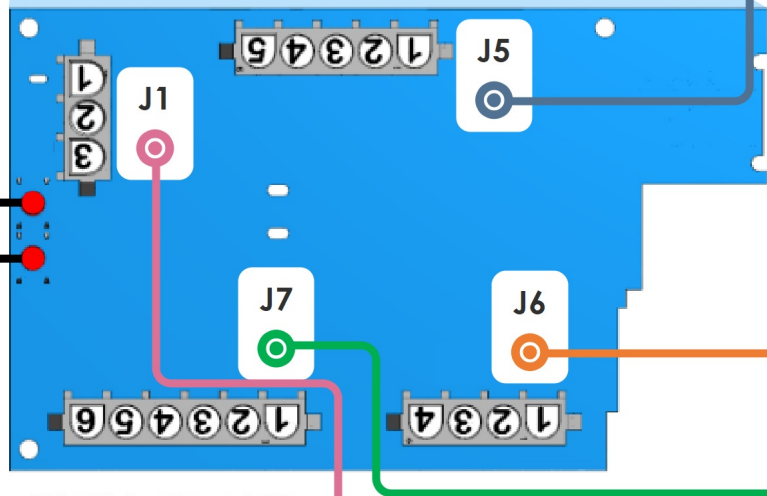
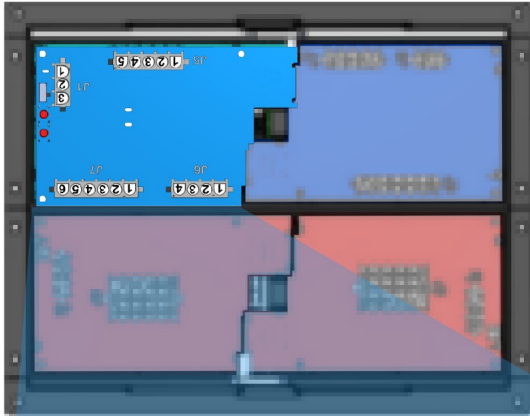

M1 Slide (Card 1)

OVERRIDE EXT

OVERRIDE RET

**i** **Emergency Override**  
For more information on the slide overrides please see Page 13

**J5**

① Awning Constant	④ Slide Breaker #2
② Undercoach Constant	⑤ Slide Breaker #3
③ Slide Breaker #1	

**J6**

① P/S FR Slide Ext	③ D/S FR Slide Ext
② P/S FR Slide Ret	④ D/S FR Slide Ret

**J7**

① P/S RR Slide Ext	④ D/S RR Slide Ret
② P/S RR Slide Ret	⑤ Hydraulic Pump
③ D/S RR Slide Ext	⑥ Spare

**J1**

① Ignition (+12V)	③ Spare
② Park Brake (GND)	

## Front M1 Panel

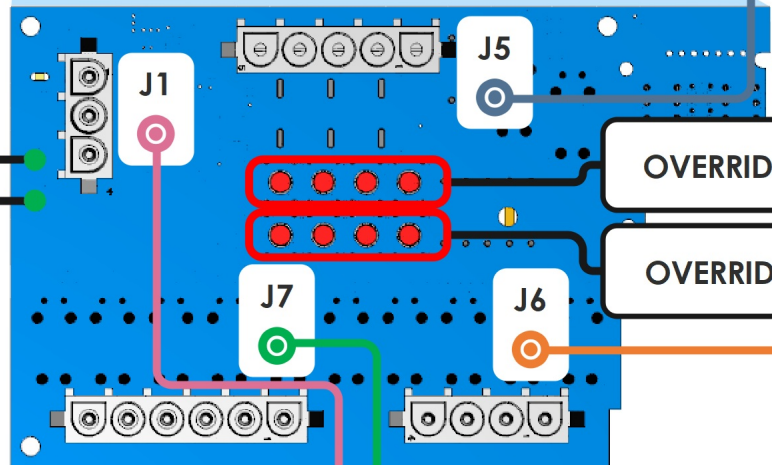
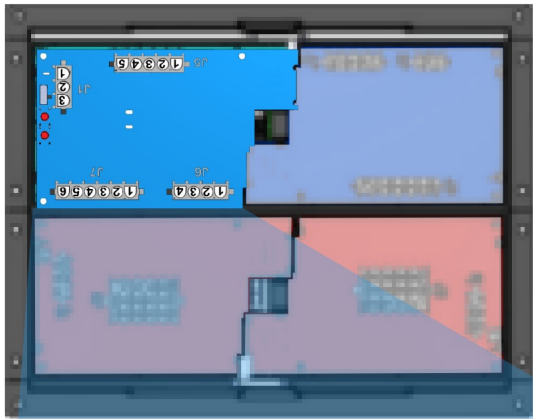

OVERRIDE RET

OVERRIDE EXT

## M1 Slide (Card 1)

Slides Ready LED

Awnings Ready LED

**i** **Emergency Override**  
For more information on the slides please see Page 14

**J5**

1 Awning Constant	4 Slide Breaker #2
2 Undercoach Constant	5 Slide Breaker #3
3 Slide Breaker #1	

**J6**

1 P/S FR Slide Ext	3 D/S FR Slide Ext
2 P/S FR Slide Ret	4 D/S FR Slide Ret

**J7**

1 P/S RR Slide Ext	4 D/S RR Slide Ret
2 P/S RR Slide Ret	5 Hydraulic Pump
3 D/S RR Slide Ext	6 Spare

**J1**

1 Ignition (+12V)	3 N/A
2 Park Brake (GND)	

## M1 Front Panel

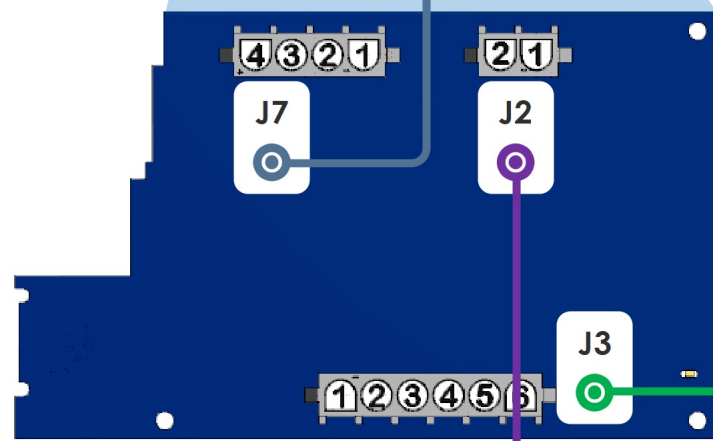
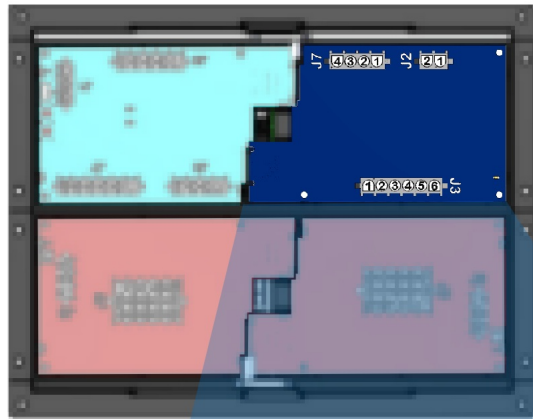

M1 HC Relay (Card 2)

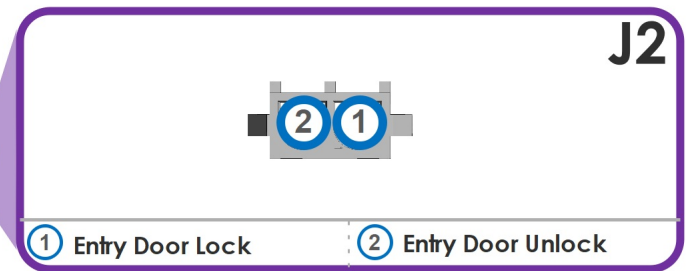
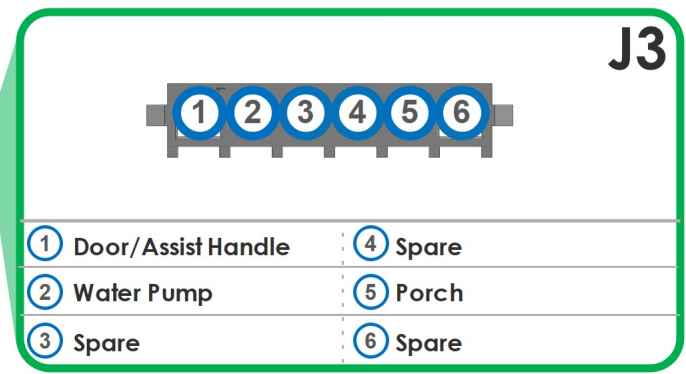
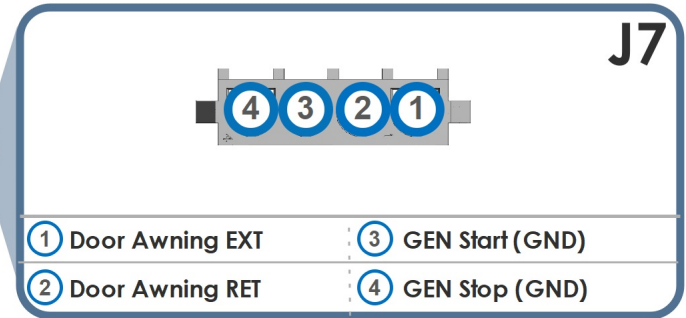

M1 Front Panel

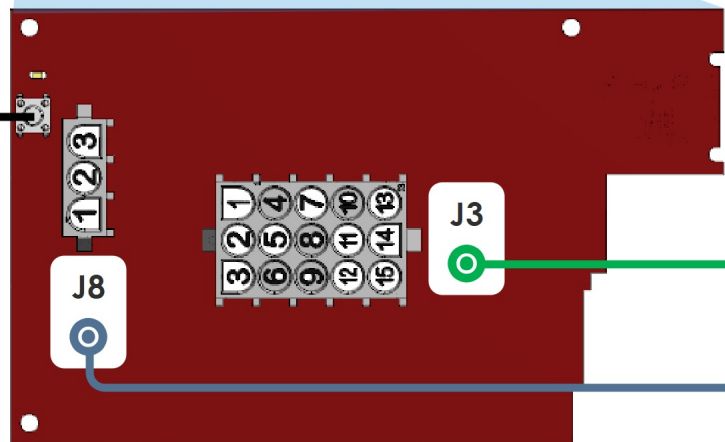
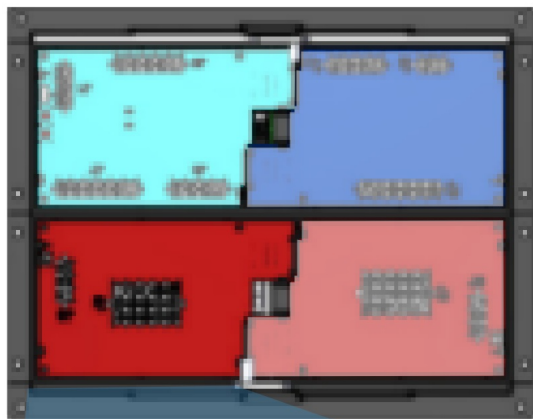

M1 Breaker (Card 3)

Breaker Reset

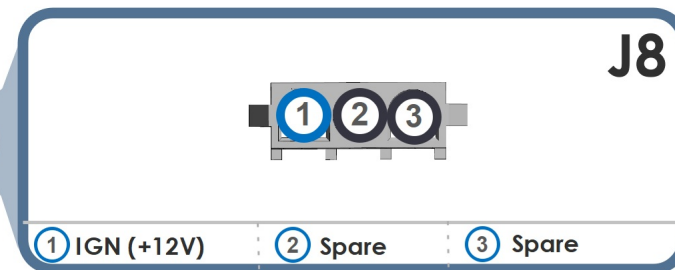
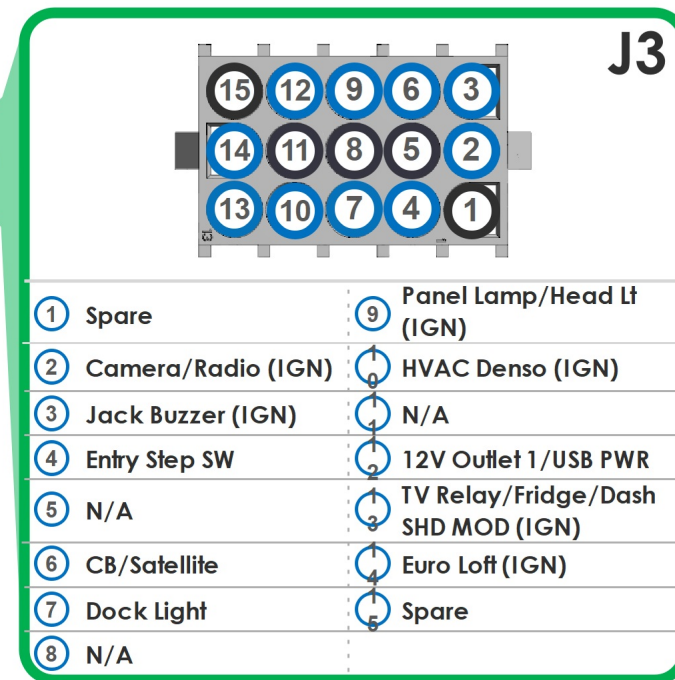

M1 Front Panel

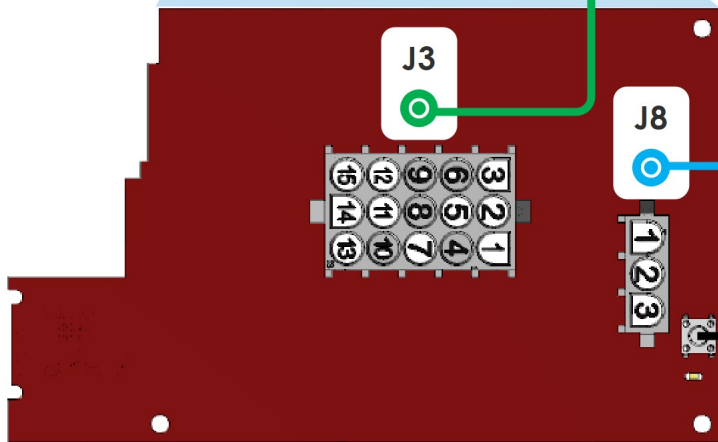
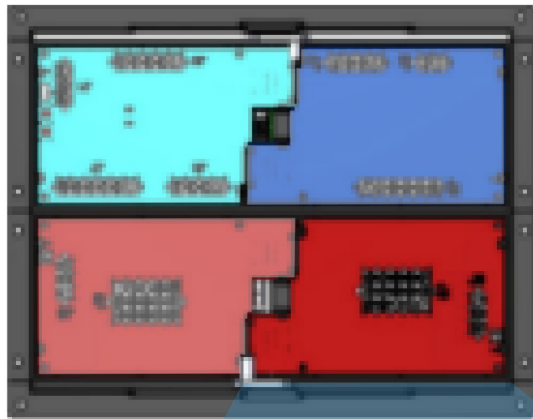

M1 Breaker (Card 4)

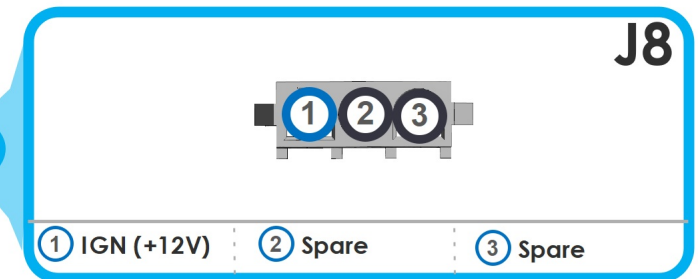
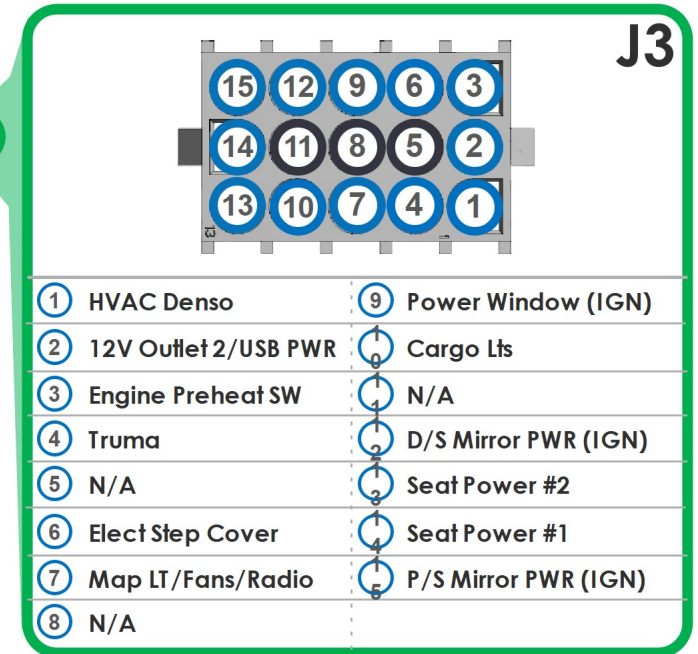

## G12 Module @ Under Bed

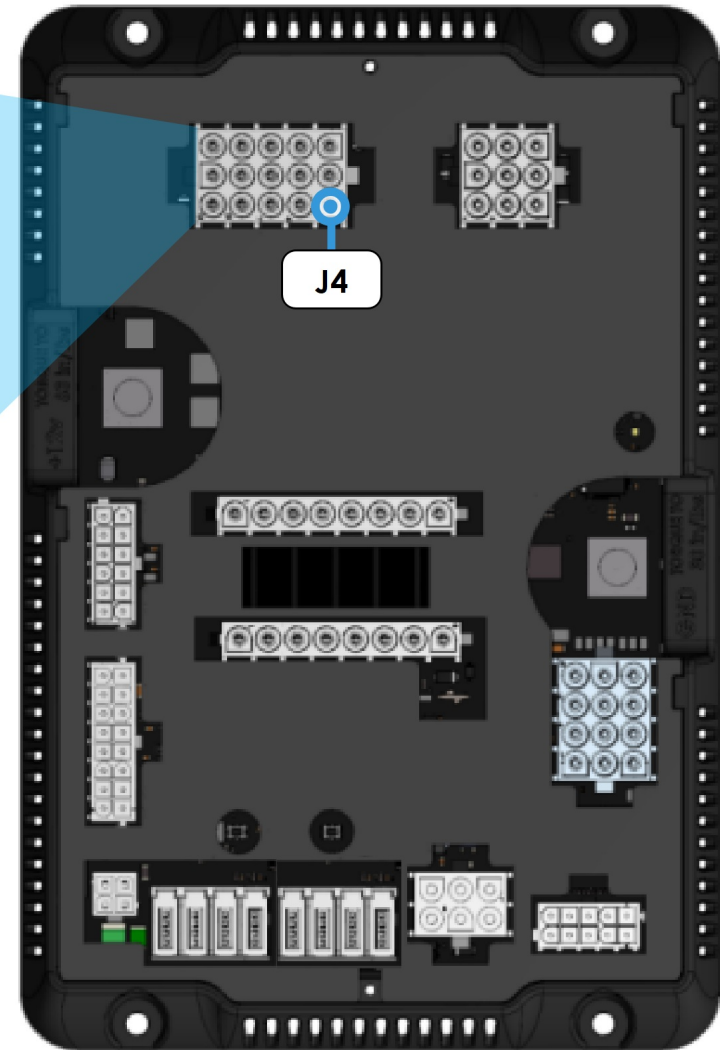
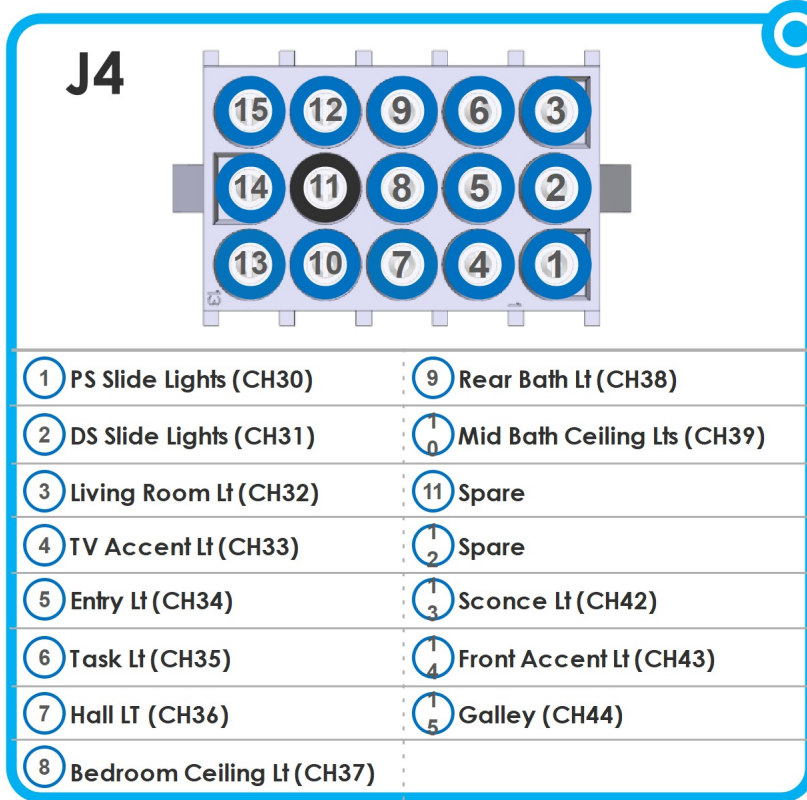

\* All Lights Listed Can Dim

\* All lights are grounded outside of the Spyder System. The G12 only provides 12V+

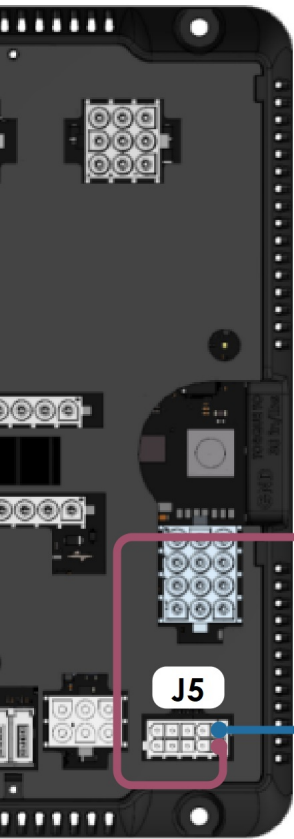

G12 Module  
@ Under Bed

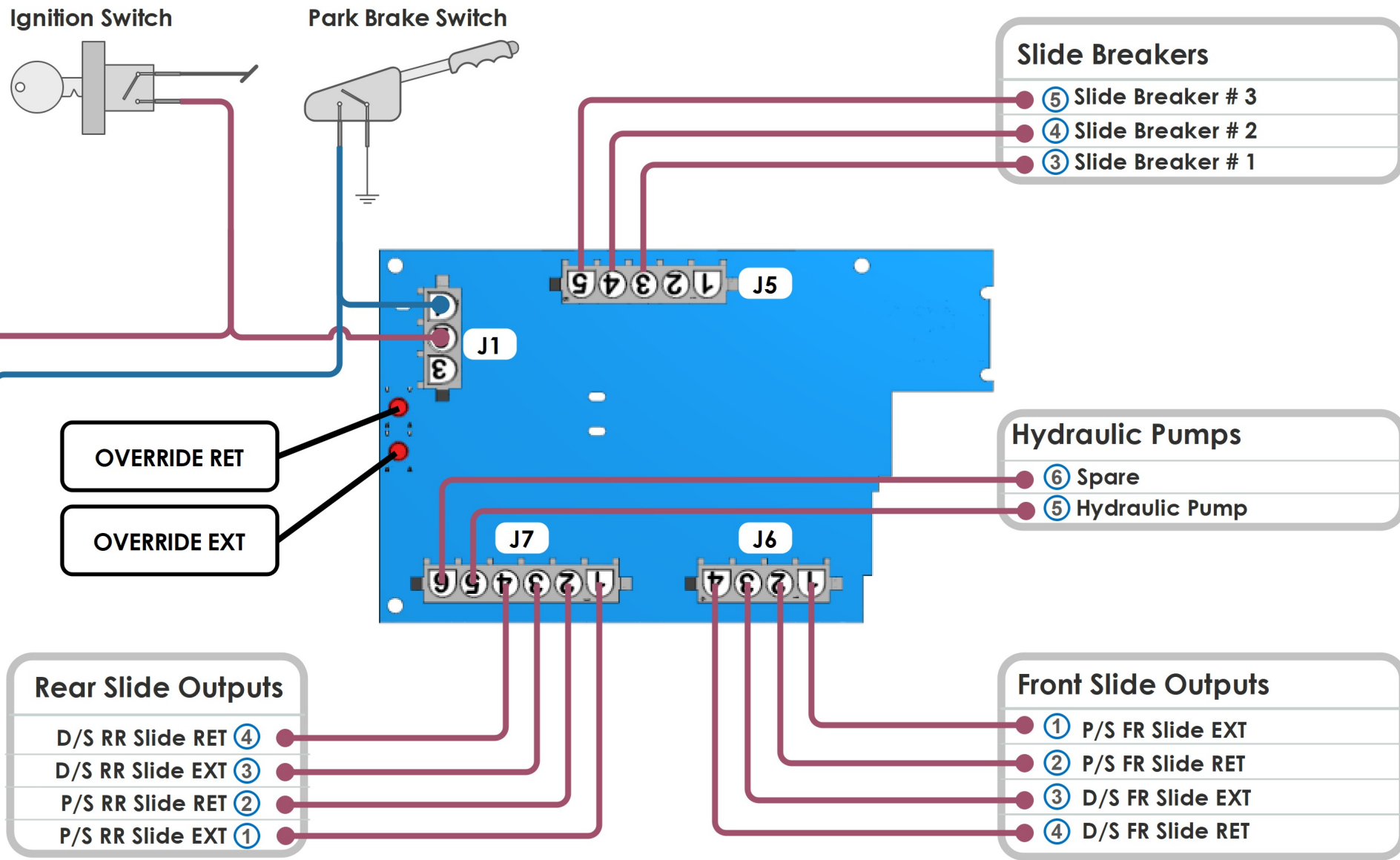

**i** **Emergency Override**  
 Park brake and ignition must be on for slides to operate.  
 In case of a system failure, use manual overrides on the slide card to operate slides. Engage overrides using a pen or other pointed object.

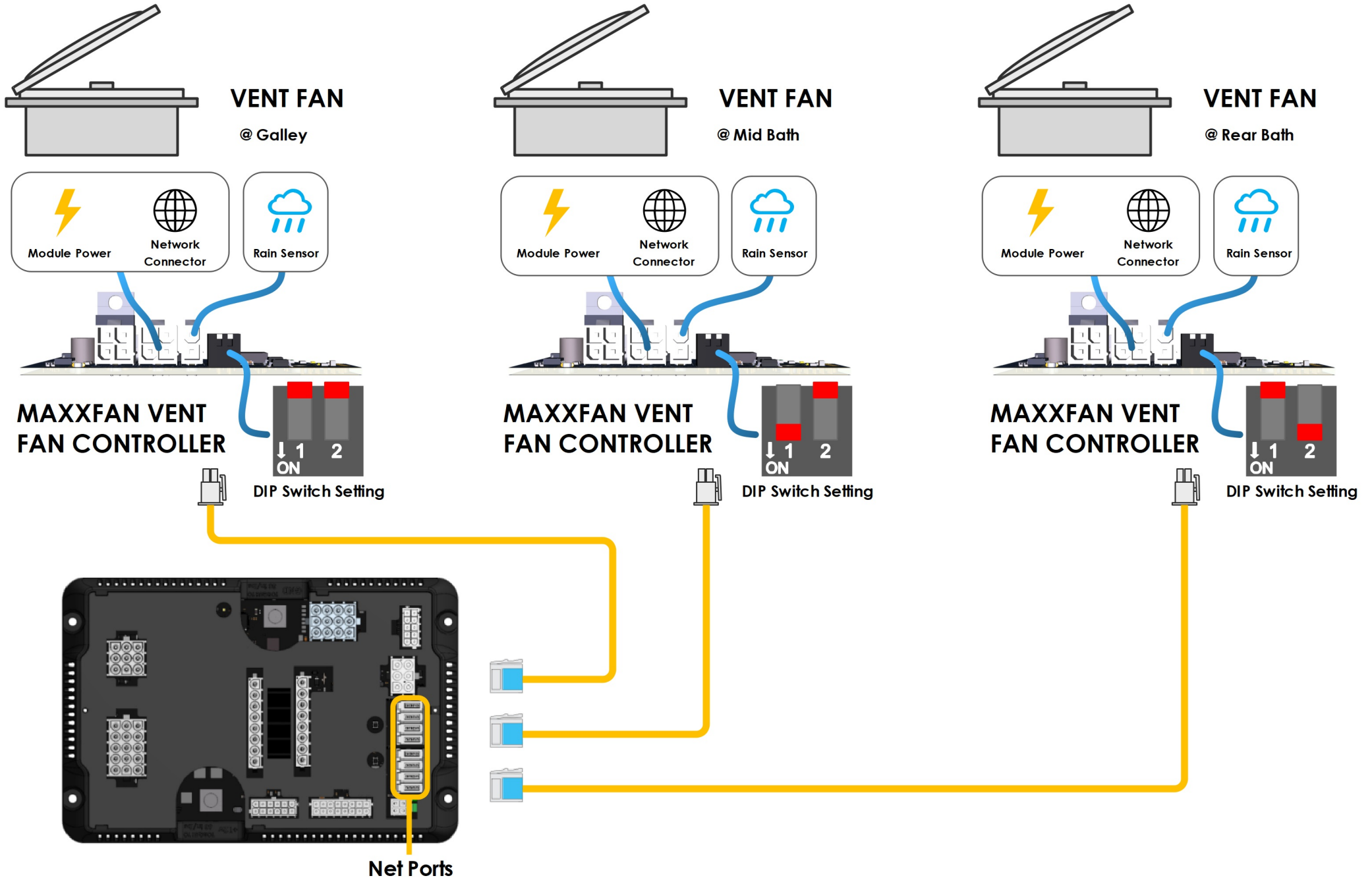

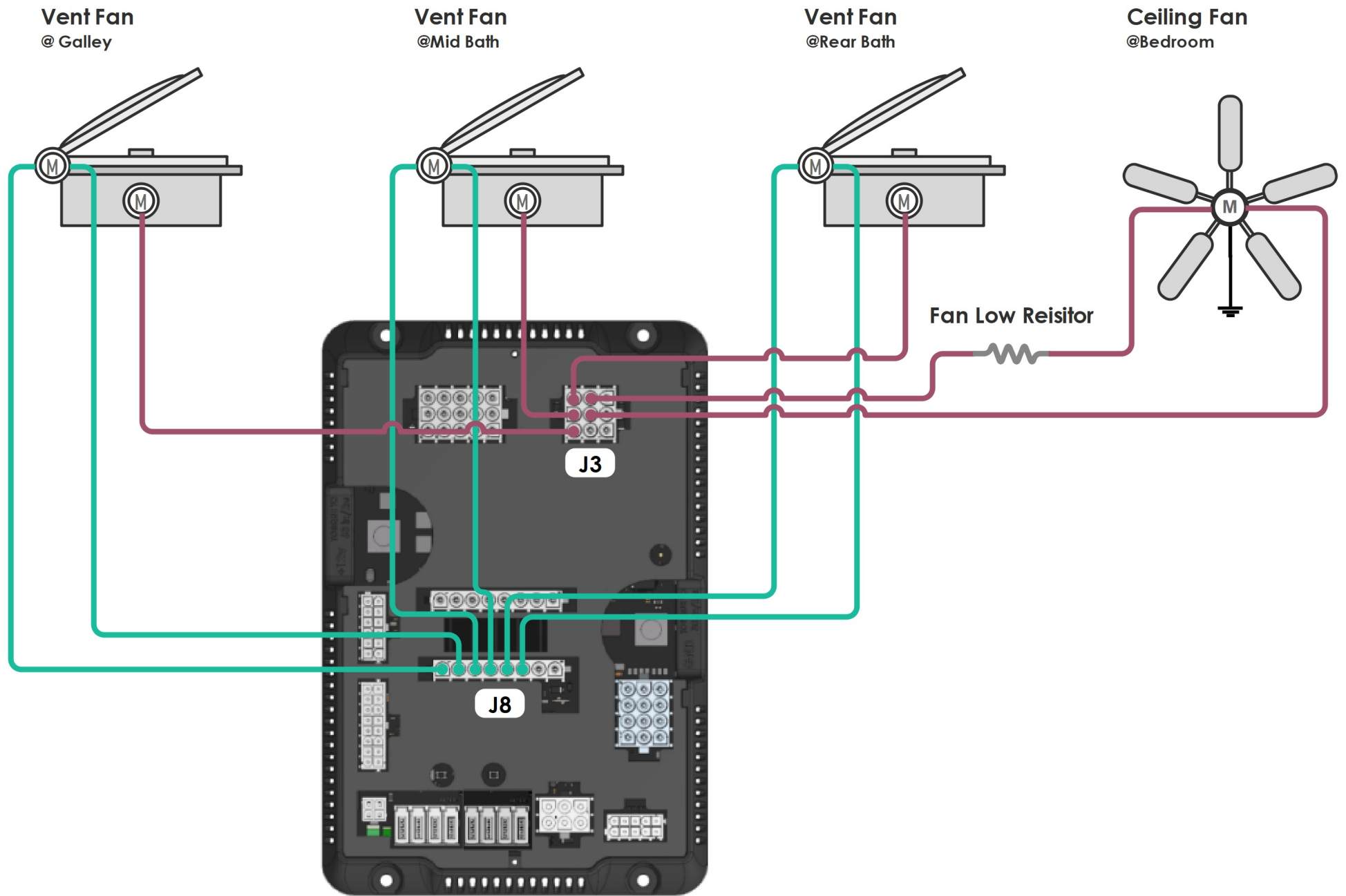

**G12 Module**  
@ Under Bed

## G12 Module

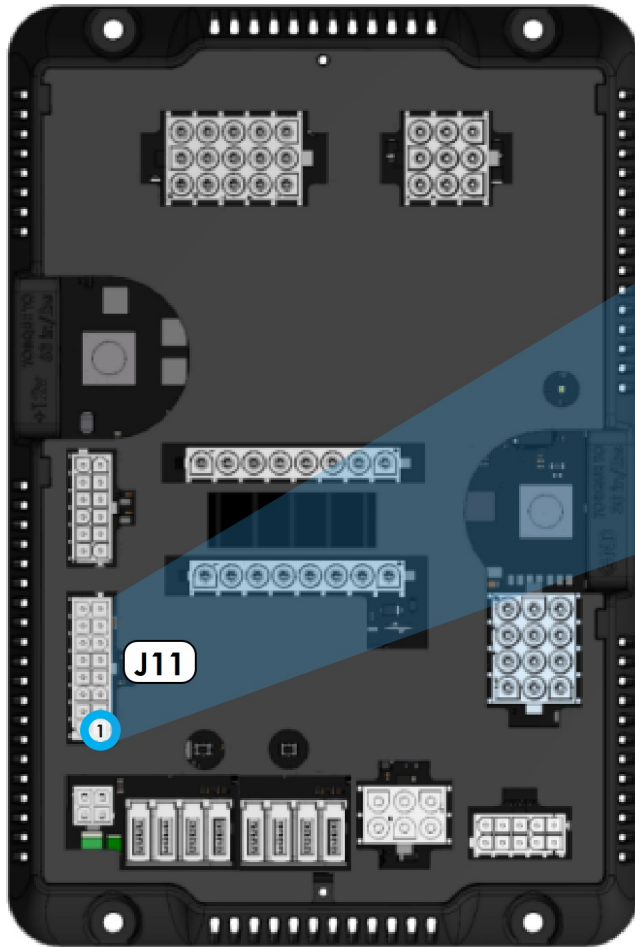

## 3 Level Tank Sensor System

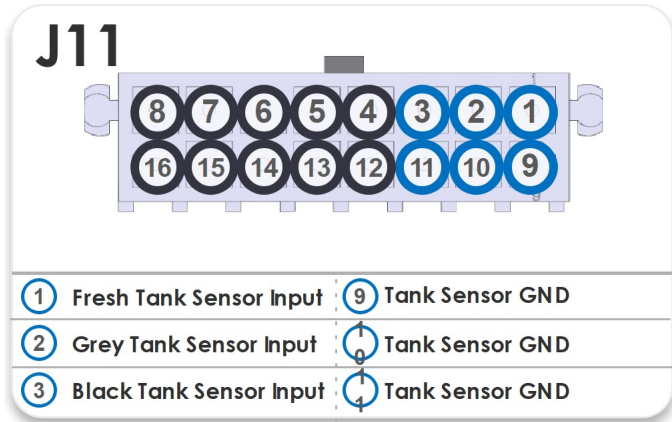
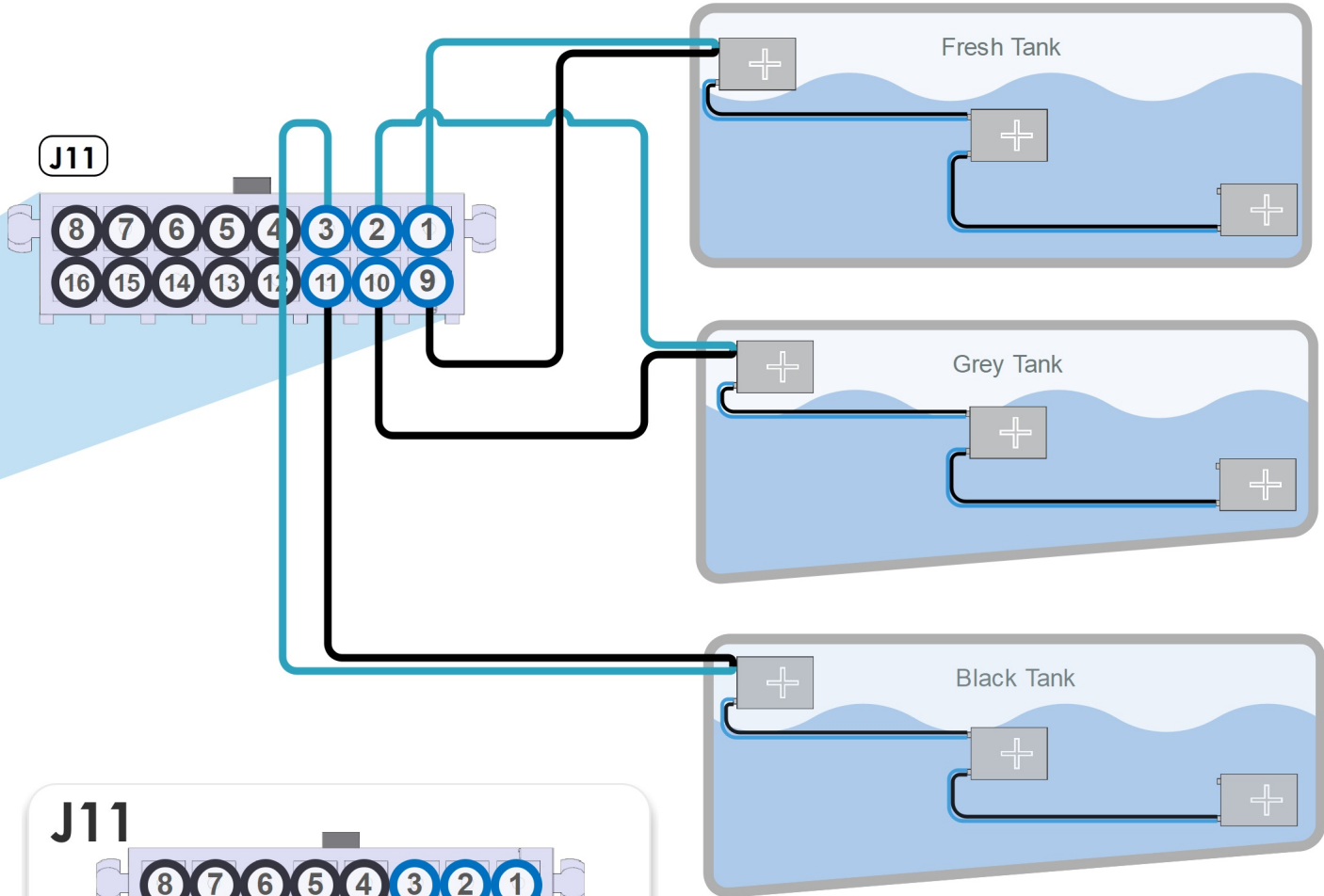

**G12 Module**  
@ Under Bed

**TruState**  
© DCD Panel

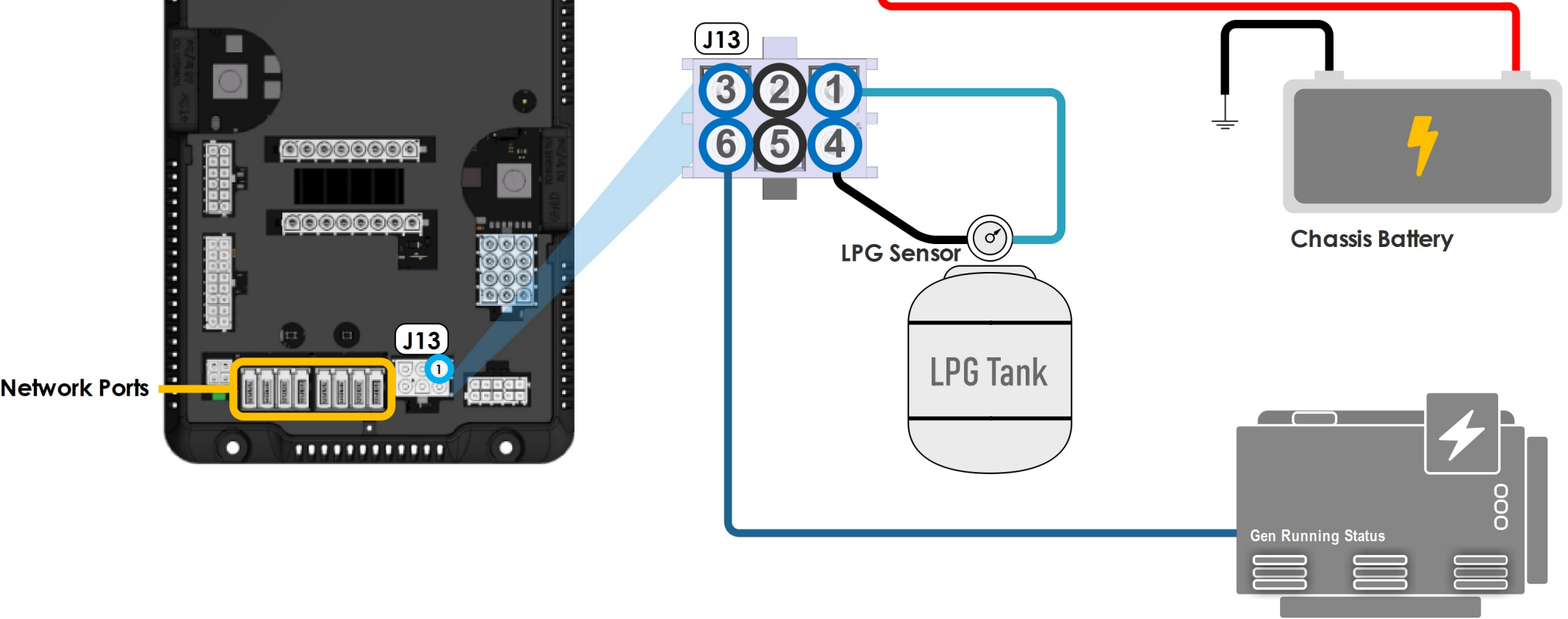
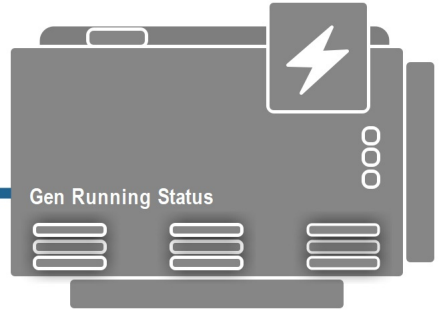
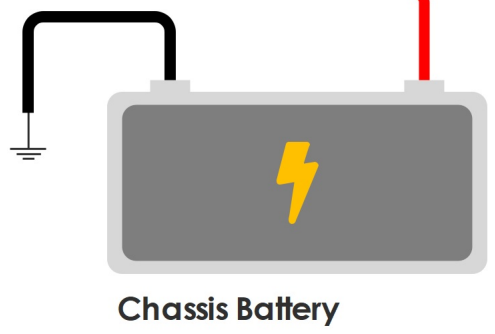
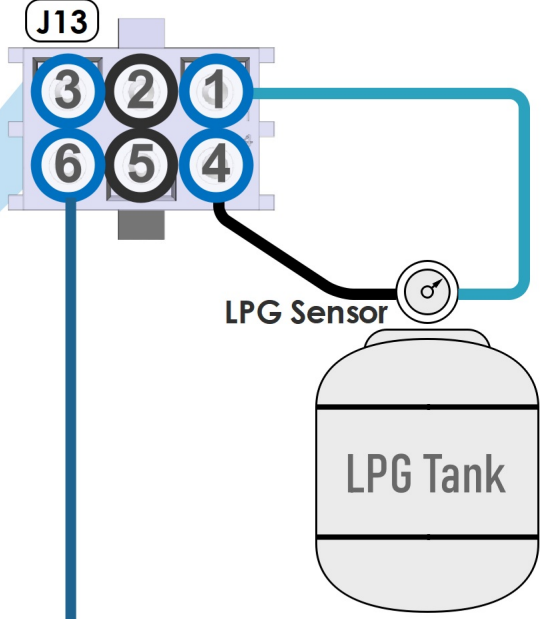
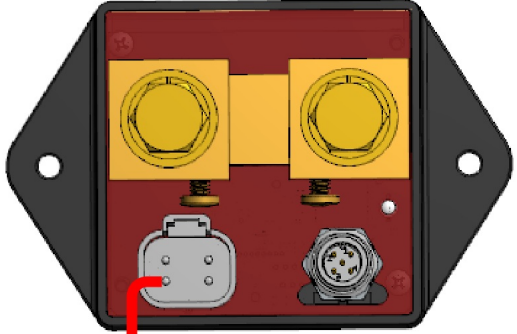
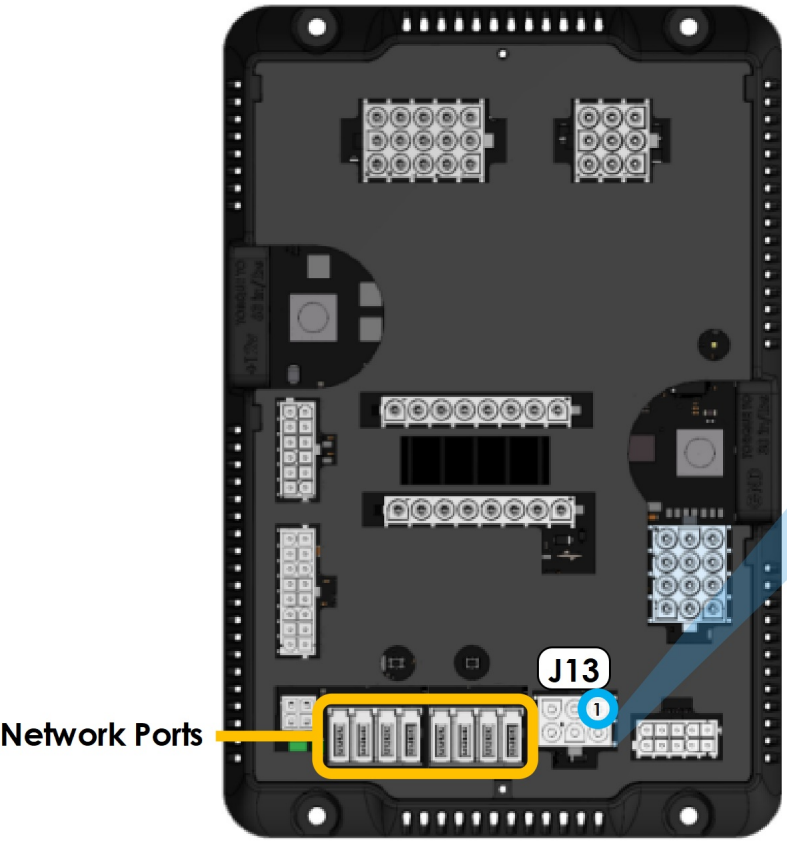

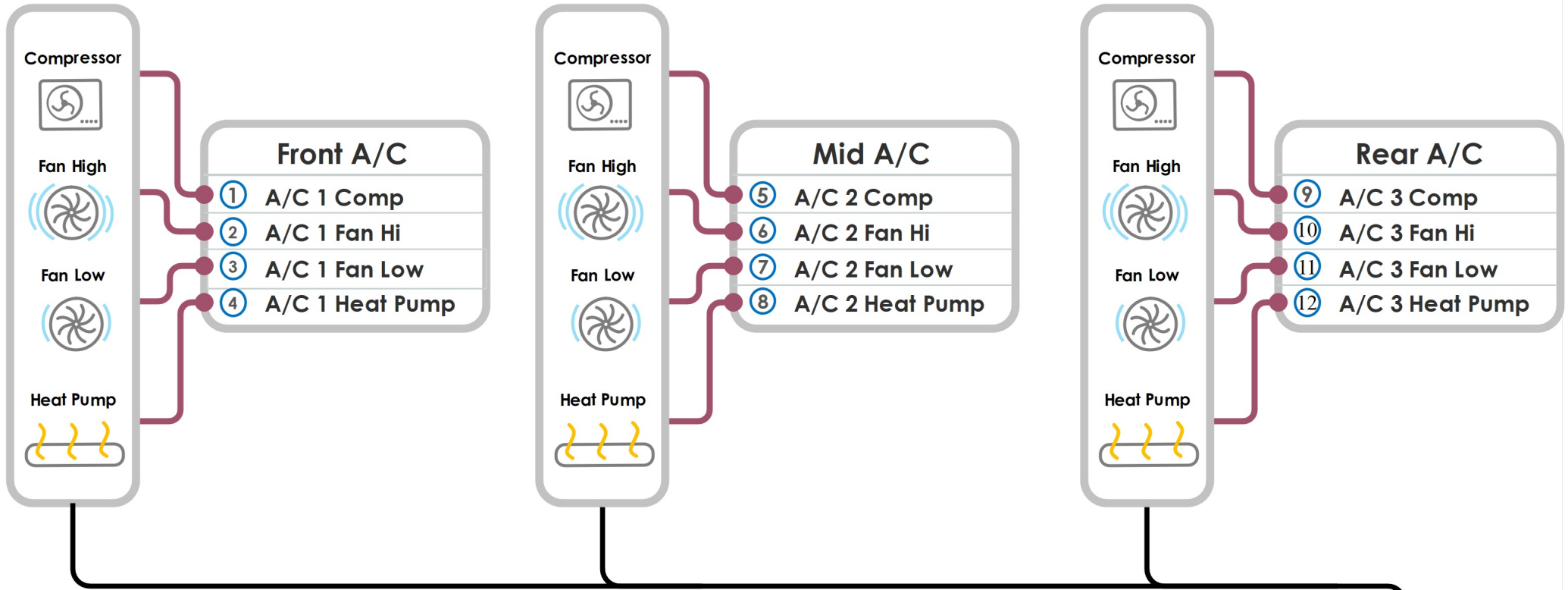

Front Furnace    Rear Furnace

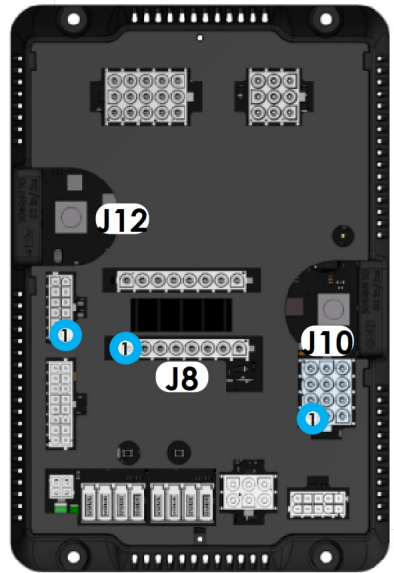
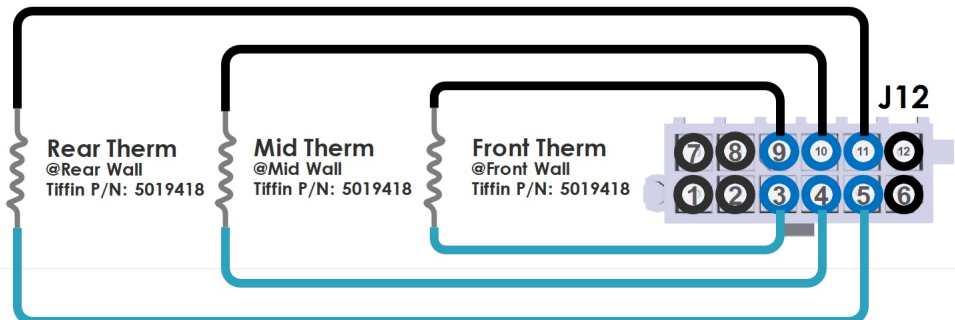
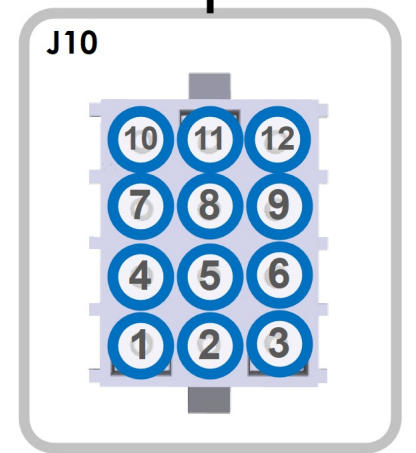
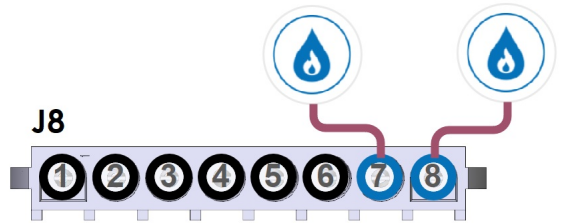

**G12 Module**  
@ Under Bed

## G12 Module

@ Under Bed

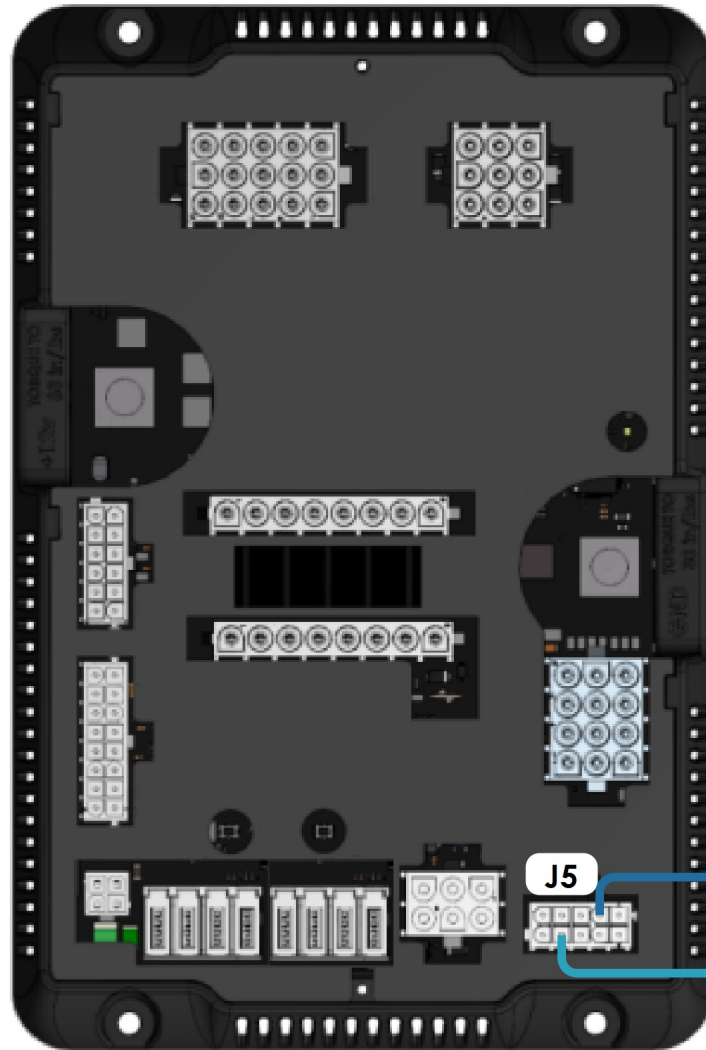

## Gas Water Heater



Water Heat Status

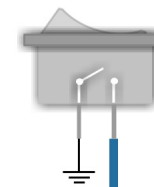

Water Pump Switch  
@ Wet Bay

J5



**Bridge Module**  
@Under Bed by G12

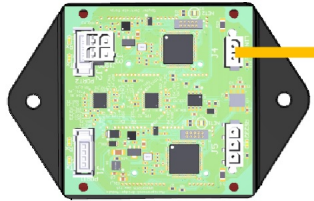

**M1 Breaker Card**

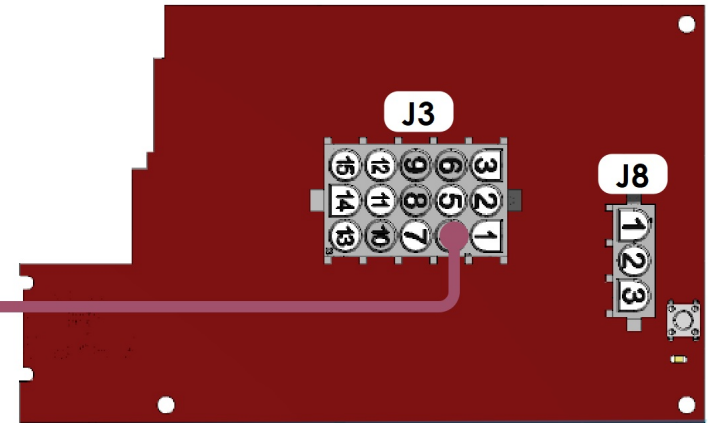

**M1 Front Panel**

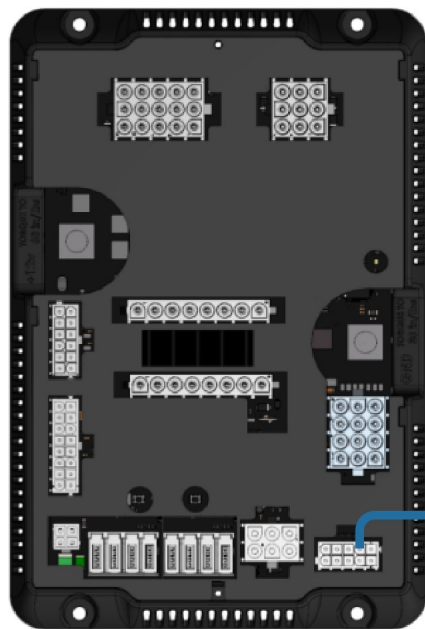

**G12 Module**  
@ Under Bed

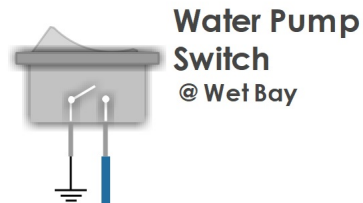

**Water Pump Switch**  
@ Wet Bay

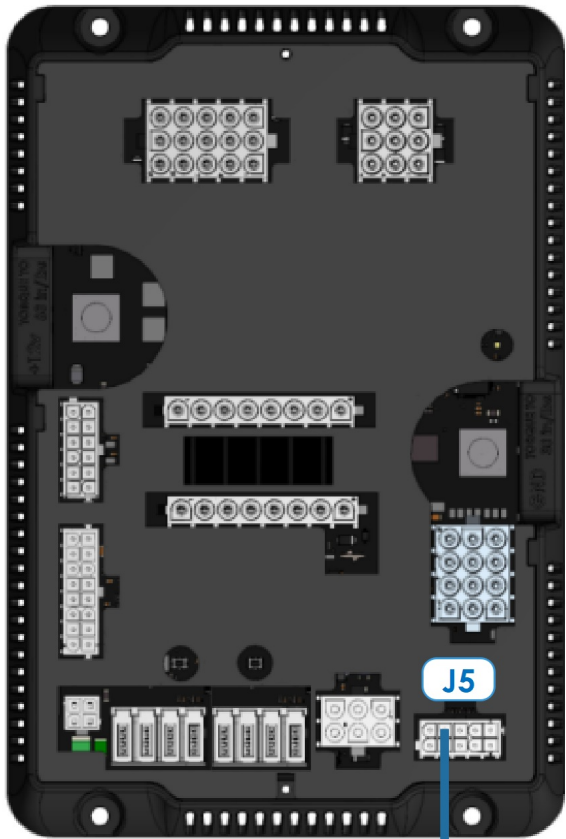

**G12 Module**  
@ Under Bed

### COACH RUNNING INPUT

Depending on the chassis used in the coach the coach running input will either come from the engine (switched GND) or from the ignition (switched 12V+)

Two green circular icons are shown: one with a white engine symbol and another with a white key symbol, representing the two possible sources for the coach running input.

**DCD PANEL**  
@ Inverter Bay

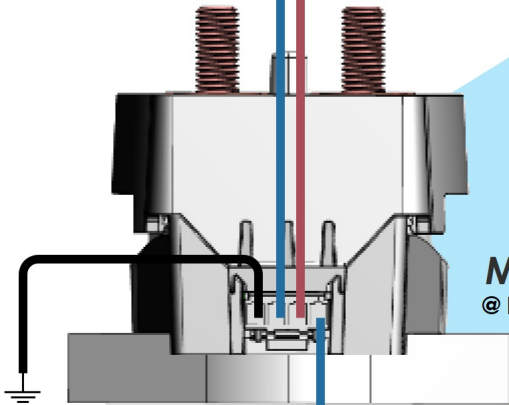
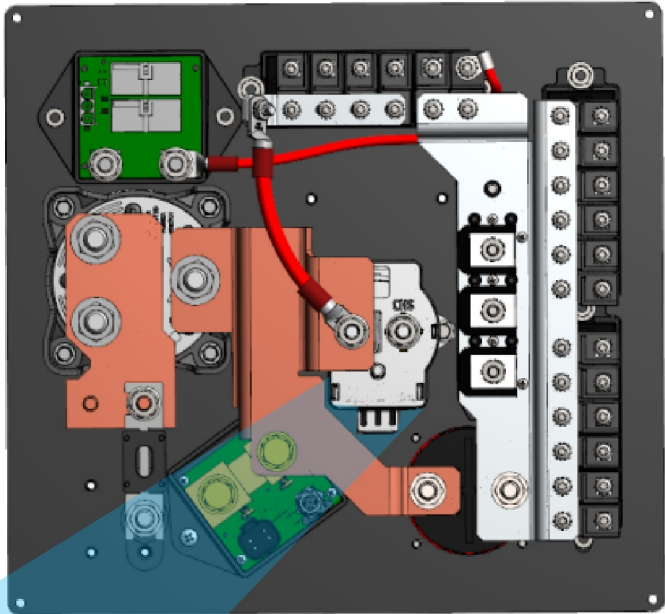

**MERGE SOLENOID**  
@ Back of DCD

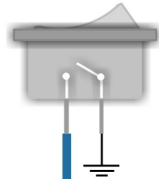

**Manual Merge Override Switch**  
@ Dash

Auto / Manual Merge Input (GND)

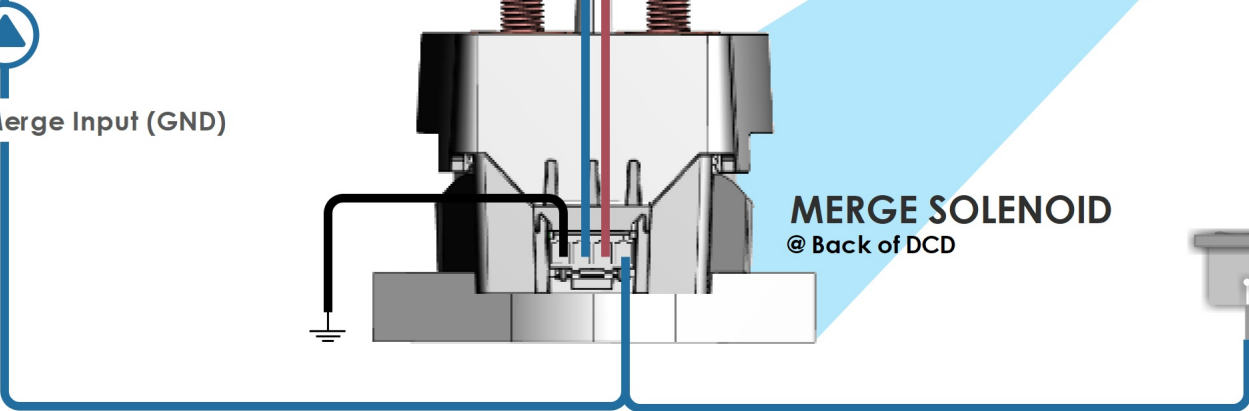

**i** **AGS**  
 When AGS is on, the Generator will start when your batteries reach the percentage specified in the AGS settings page. The Generator will also start if there is an HVAC load present.

Front M1 Panel

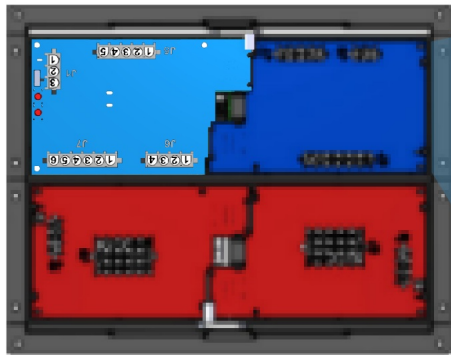

M1 HC Relay Card

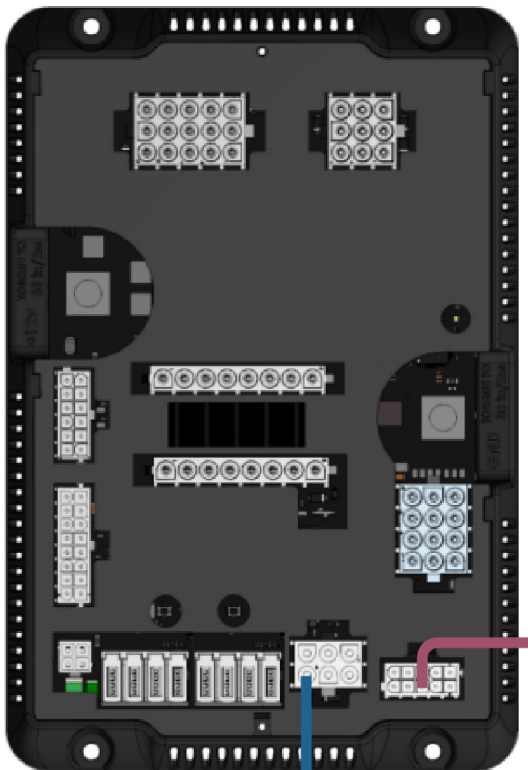
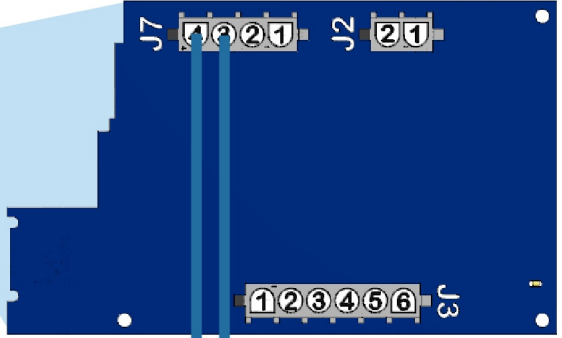

G12 Module

@ Under Bed

120V BREAKER PANEL

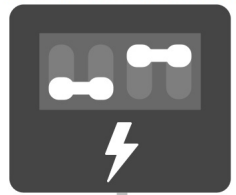

120V AC - 12V DC

**i** **Shore Power Detection**  
 When the G12 is receiving +12V on Connector J5 Pin 8, for the shore power detection, AGS will remain in the off state until shore power is disconnected.

Gen Start (GND)

Gen Stop (GND)

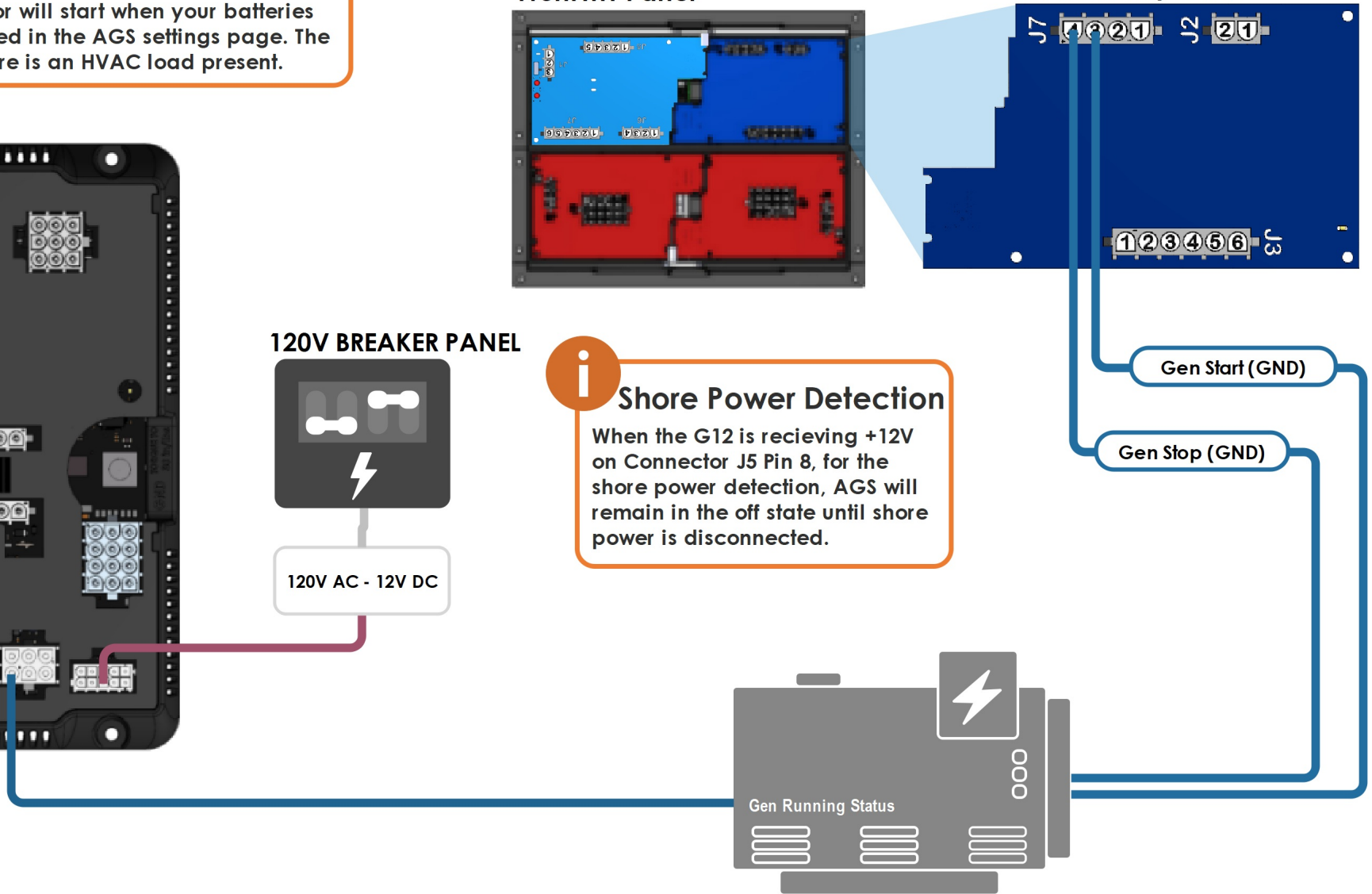
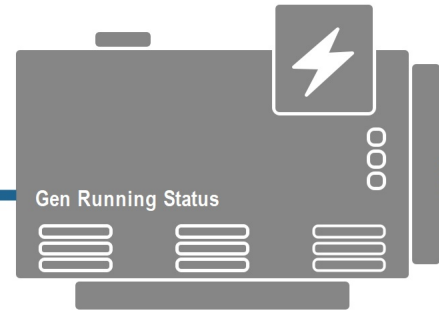

M1 Front Panel

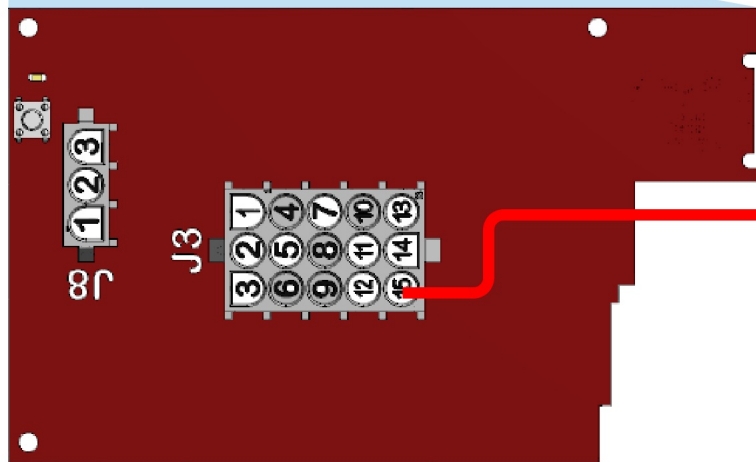
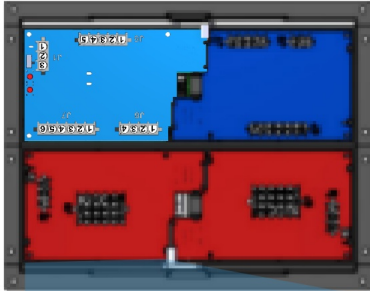

M1 Breaker Card

Ignition Switch

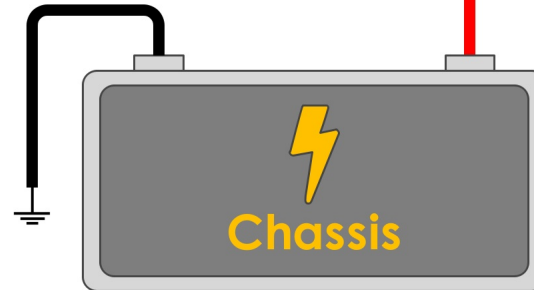
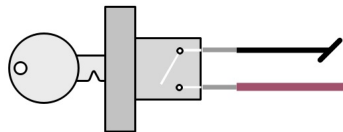

Terminator  
HCR-11 Drop Tap  
© Front D/S Comp

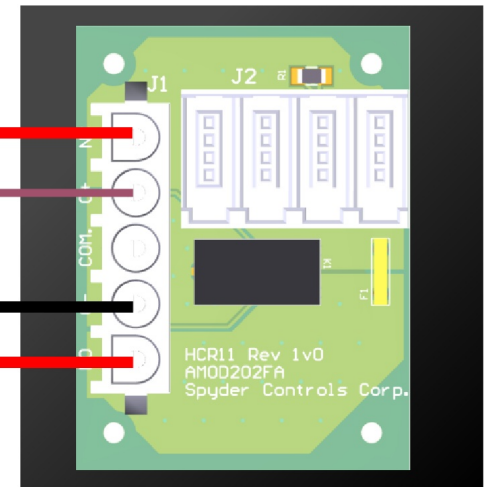

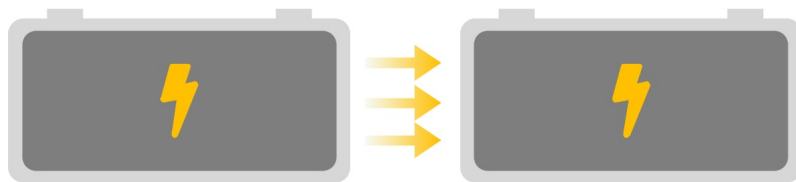
**CHASSIS BATTERY**

⚡ 13.3V+ Or Higher

🕒 30 Seconds

🔑 V+

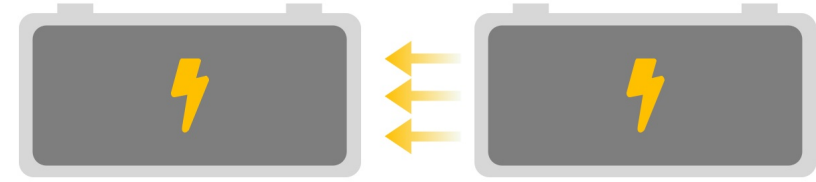
**HOUSE BATTERY****CHASSIS BATTERY**

⚡ 12.4V+ Or Lower

🕒 30 Seconds

V+

**HOUSE BATTERY**

⚡ 12.5V+ Or Higher

🕒 30 Seconds

V+

**MERGE LOGIC - CHASSIS CHARGING HOUSE**

The merge solenoid will engage if the following conditions are present:

- Engine run or ignition signal is present and chassis voltage is above 13.3V (charging) for 30 seconds.

The merge solenoid will disengage under either of the following conditions

- Engine run or ignition signal is removed
- Chassis voltage drops below 12.6V for more than 30 seconds (unmerge until engine is started again)

**MERGE LOGIC - HOUSE CHARGING CHASSIS**

The merge solenoid will engage if the following conditions are present:

- House voltage is above 12.5V (charging) and chassis voltage is below 12.4V (low battery voltage) for 30 seconds

The merge solenoid will disengage under either of the following conditions:

- House voltage drops below 12.2V for more than 30 seconds, OR
- 60 minutes timed battery merge period expires. Re-merge will occur again if the merge conditions are still present

**Merge Logic - Note**

The voltages used in this spec are what are read directly at the merge solenoid which is installed at the DCD panel and may vary from the voltages displayed on the LCD screens for general informational purposes



**THE ORDER OF THE NETWORK CABLES AT THIS TAP IS IMPORTANT !**

The RF Hub and M1 Panel **MUST** be plugged into the ports shown. The always on ports are powered when the house disconnect is off.

Tiffin P/N: 5105426  
**Terminator**  
HCR-11 Drop Tap  
@ Front D/S Comp

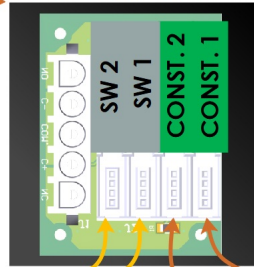

Tiffin P/N: 5126983  
**Front M1 Panel**  
@ Front D/S Comp

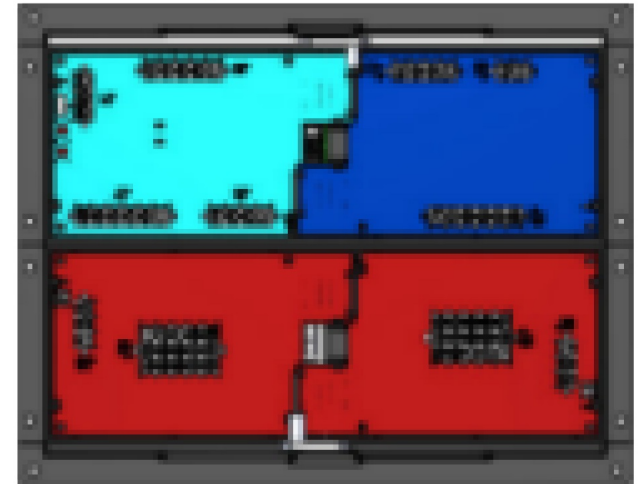

Switched Always On

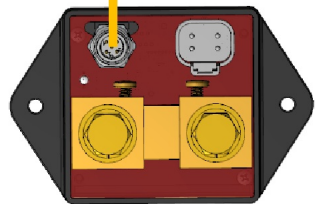

**TruState**  
@ DCD Panel

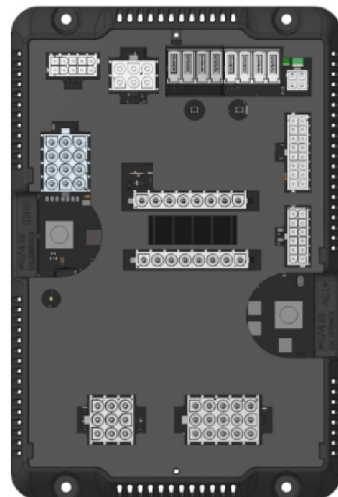

**G12 MODULE**  
@ Under Bed  
Tiffin P/N: 5126984

**Terminator**



**RF Hub**  
@Ceiling

**i** **Always On Network**

This network to remain powered while house disconnect is off.

This network can be turned off using the battery disconnect on the DCD panel.

\*(Ensure power does not transfer through the network cable to the G12, but does transfer to the RF Hub)



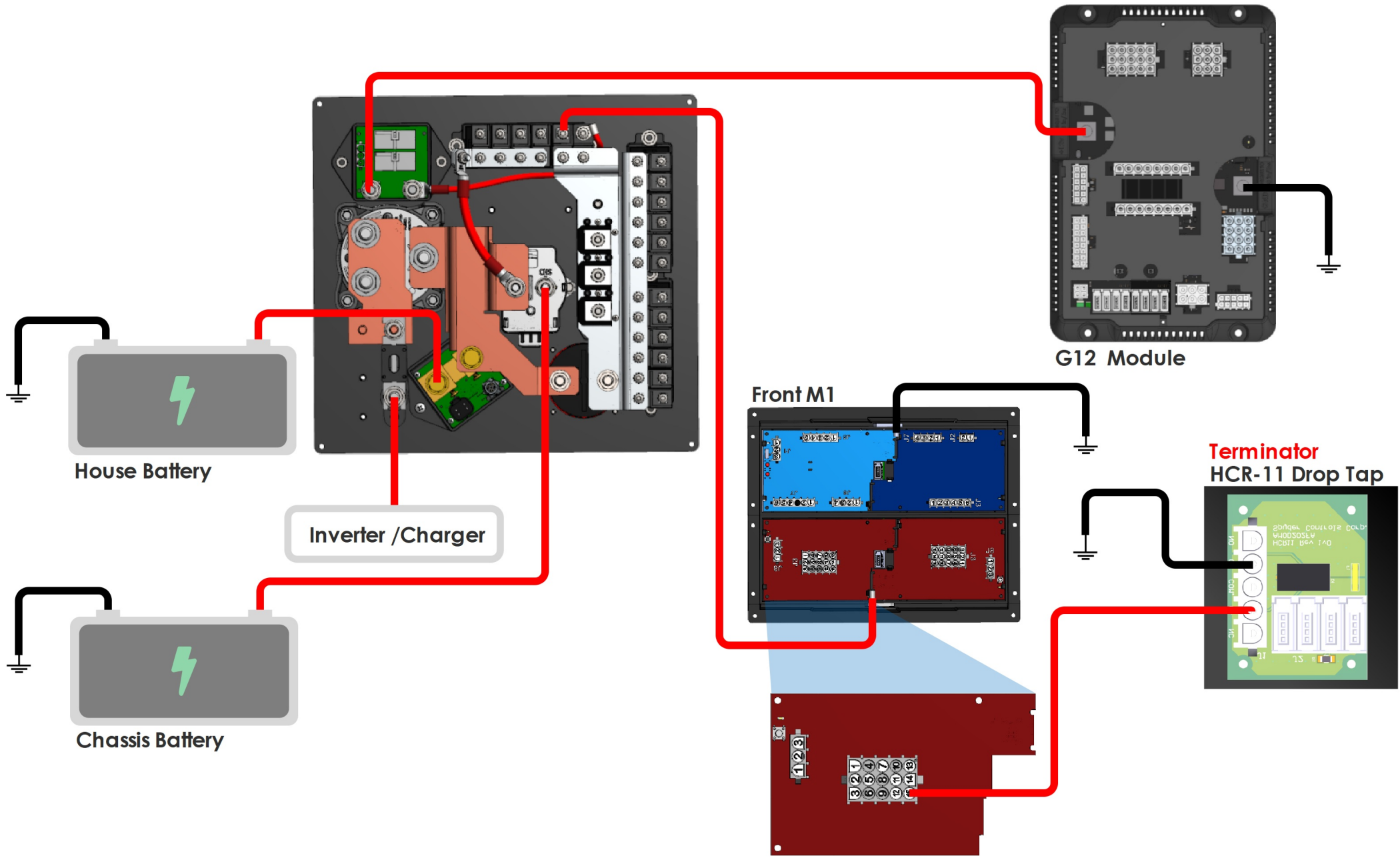

**TERMINATOR  
HCR-11**  
Tiffin P/N: 5105426

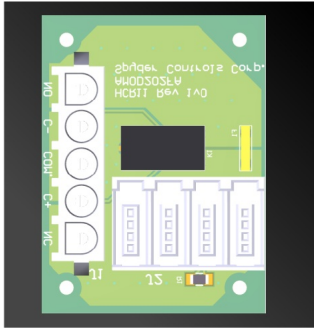

**G4 Common Drop Tap**  
Tiffin P/N: 5016592

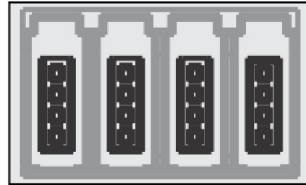

**G4 Terminator Drop Tap**  
Tiffin P/N: 5051936

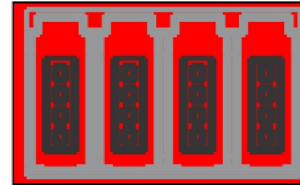

Mini-Clamp Plug  
Tiffin P/N: 5066157  
3M P/N: 37104-2165-000 FL 100



Mini-Clamp Socket  
Tiffin P/N: 5066158  
3M P/N: 37304-2165-000 FL 100



4 Pos Wago Connector  
Tiffin P/N: 5015508

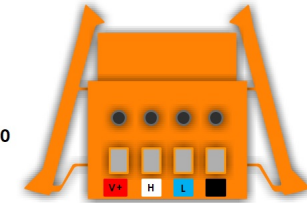

Wago Hook Tool  
Wago P/N: 231-131

